

**Z**

hdk

Zürcher Hochschule der Künste  
Bachelor of Arts in Design

# Designing Object Experience

# Sketching II

Object Experience | 23rd of September 2021

lecturer  
**Rasa Weber**

Overview

Today's Schedule

10:00

⋮

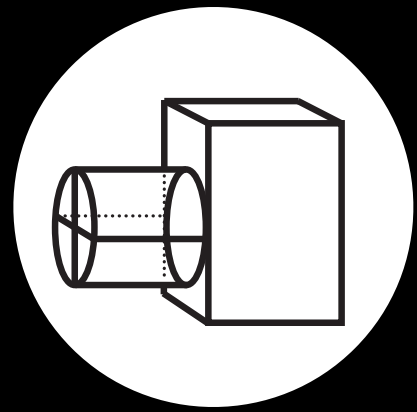

**Geometric  
Construction**

10:45

⋮

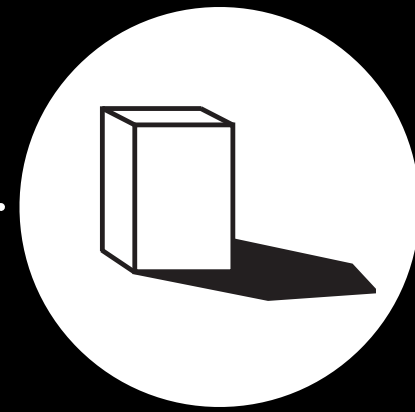

**Shadowing**

11:30

⋮

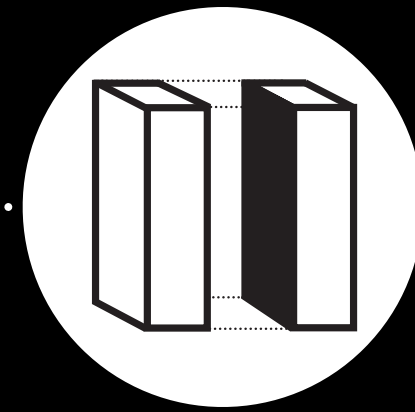

**Sections**

12:15

⋮

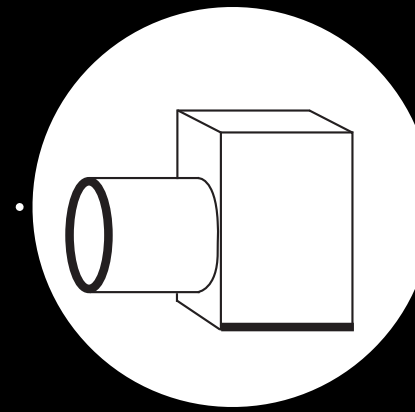

**Strokes  
Focal Point**

13:15

⋮

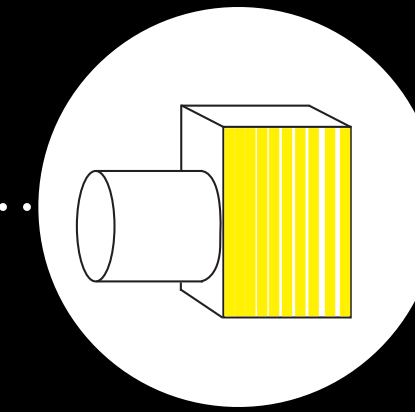

**Coloring**

SKETCHING

# CONSTRUCTIONS

Construction  
Basic Shapes

Cube

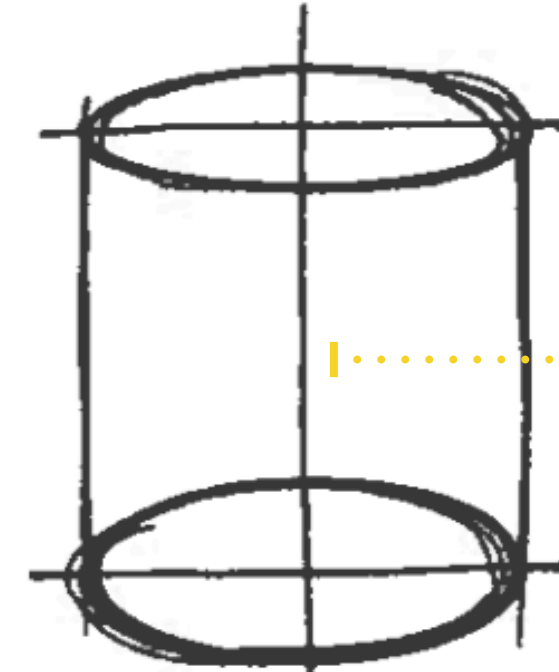
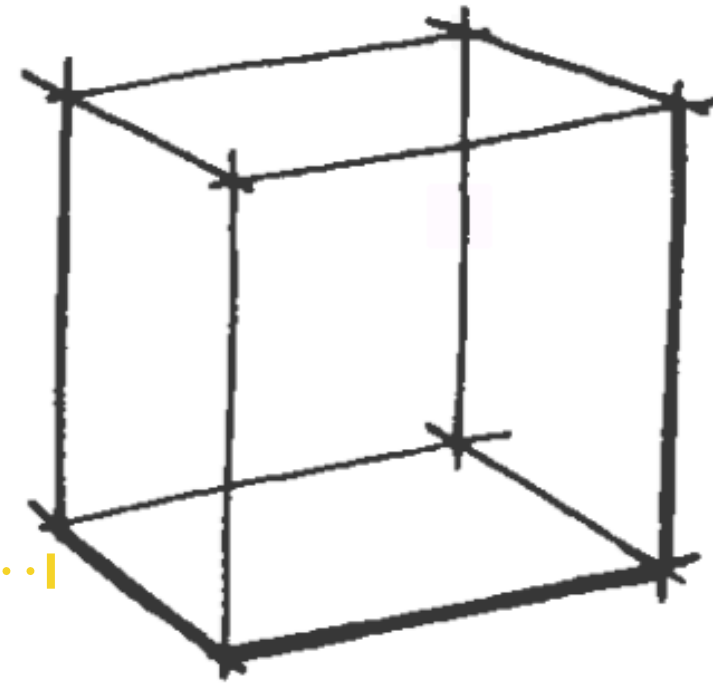

Axis

Cylinder

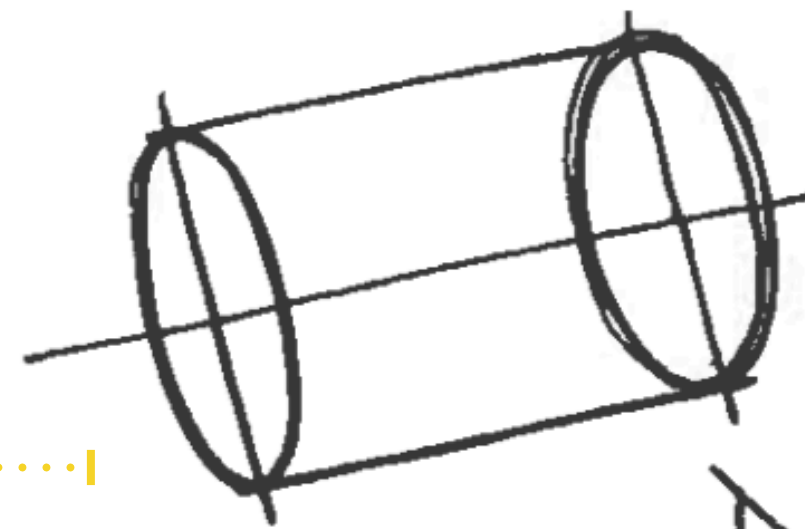

Sphere

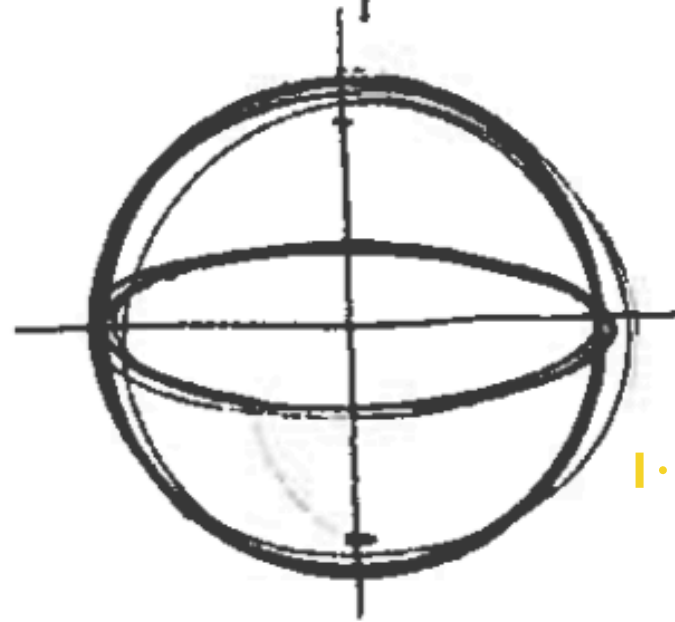

Surface

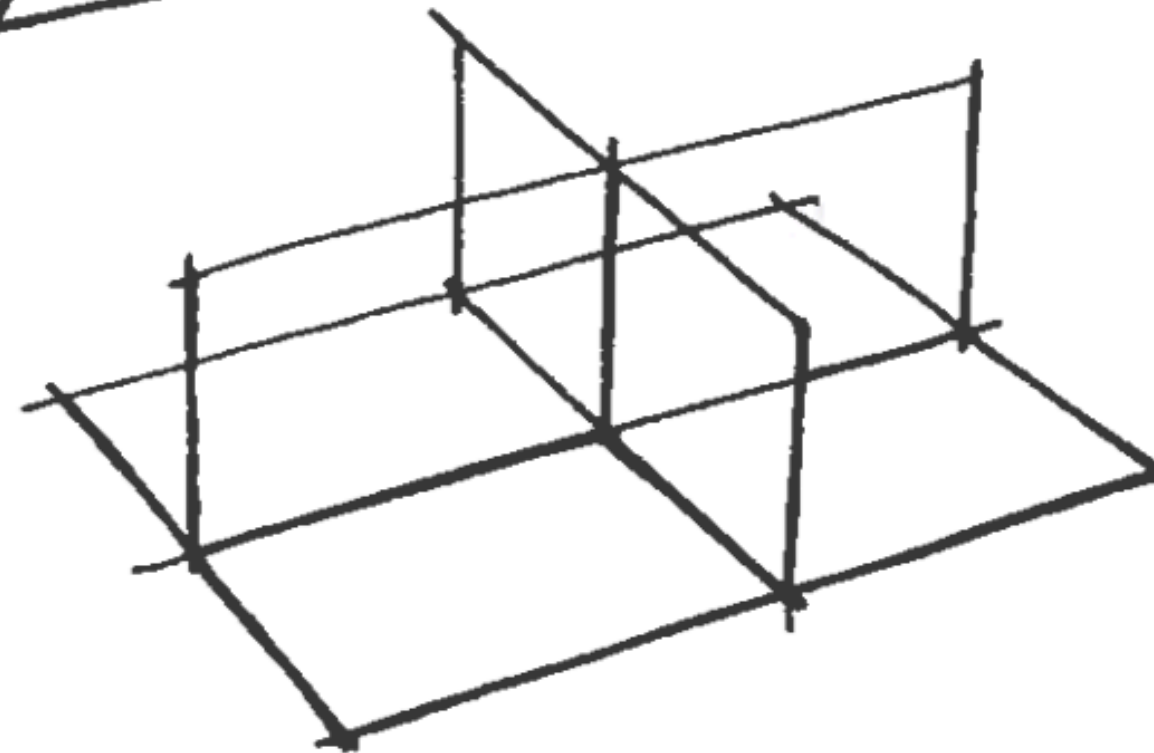

Construction  
Basic Shapes

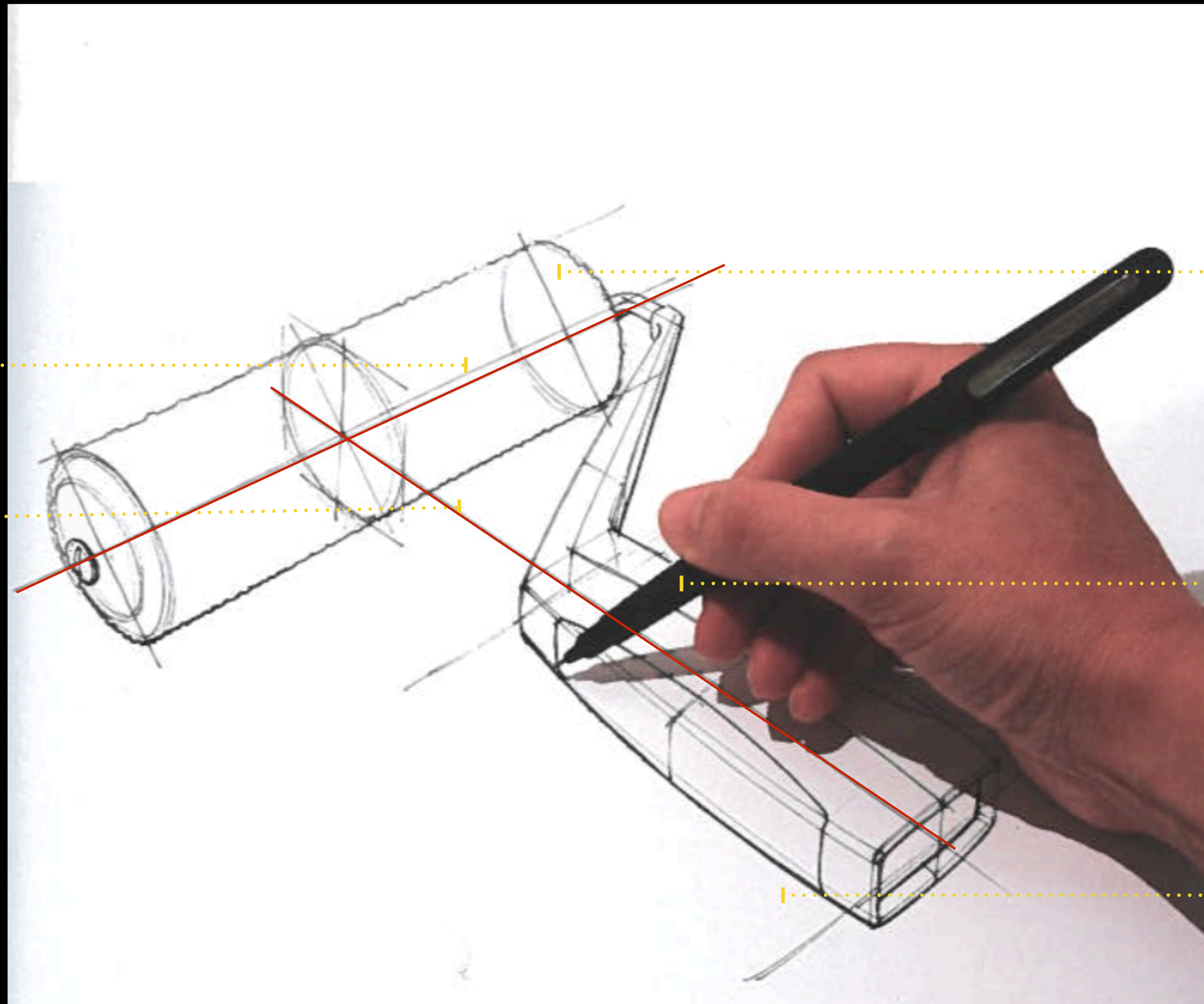

Axis II

Axis I

Cylinder

Cube

?

# Construction Basic Shapes

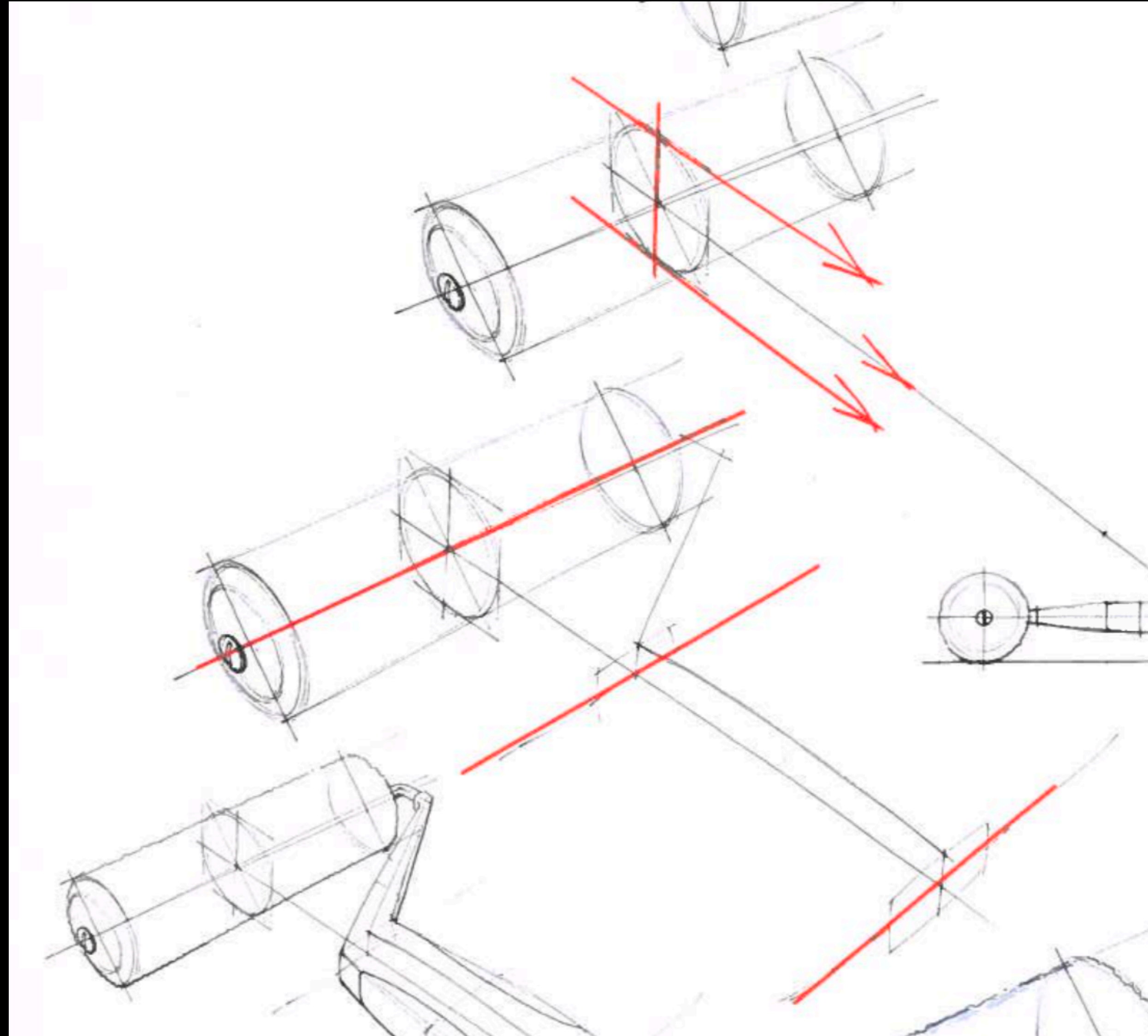

Rule 1

**NO ERASER!**

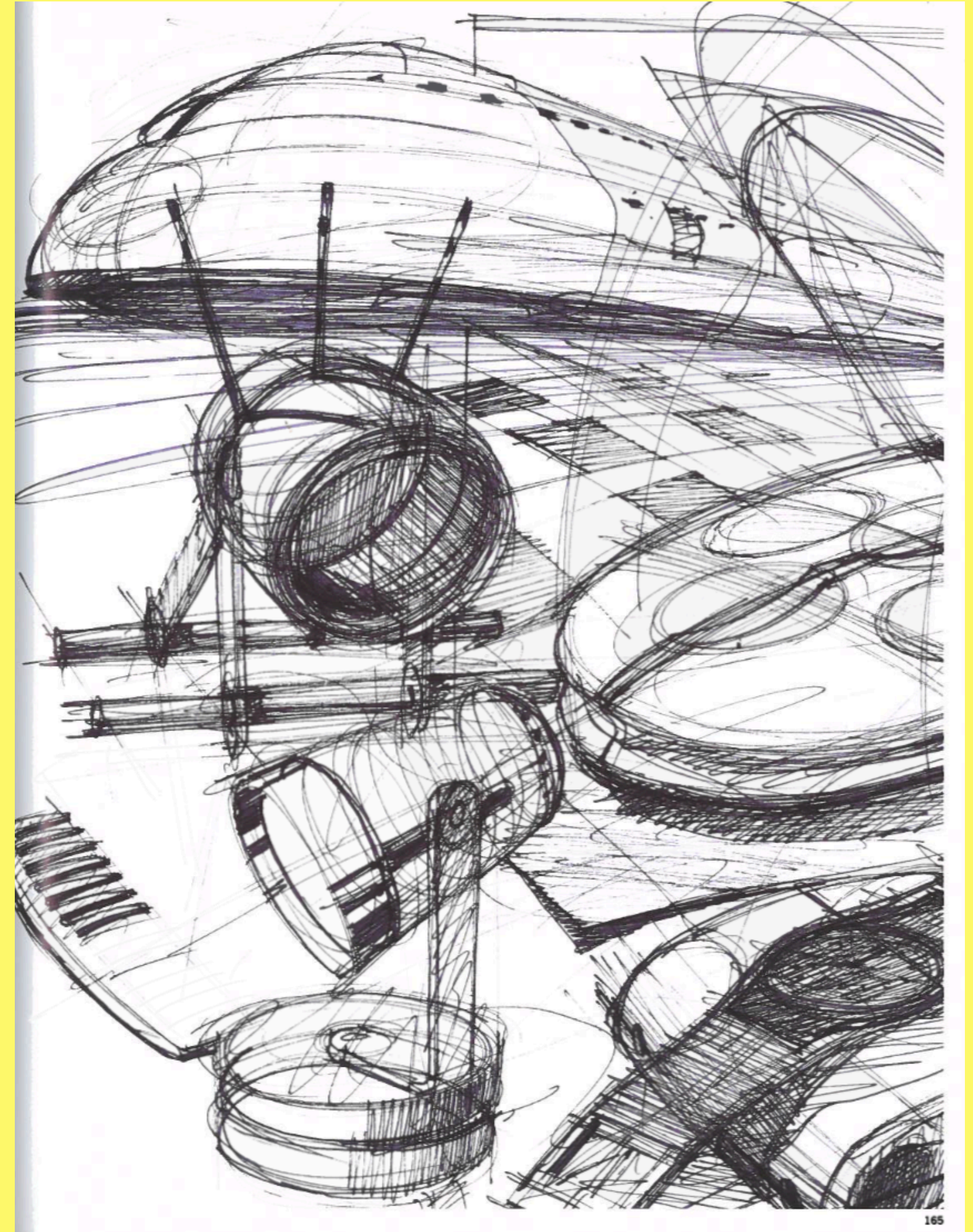

Rule 2

**NO DIGITAL AID!**

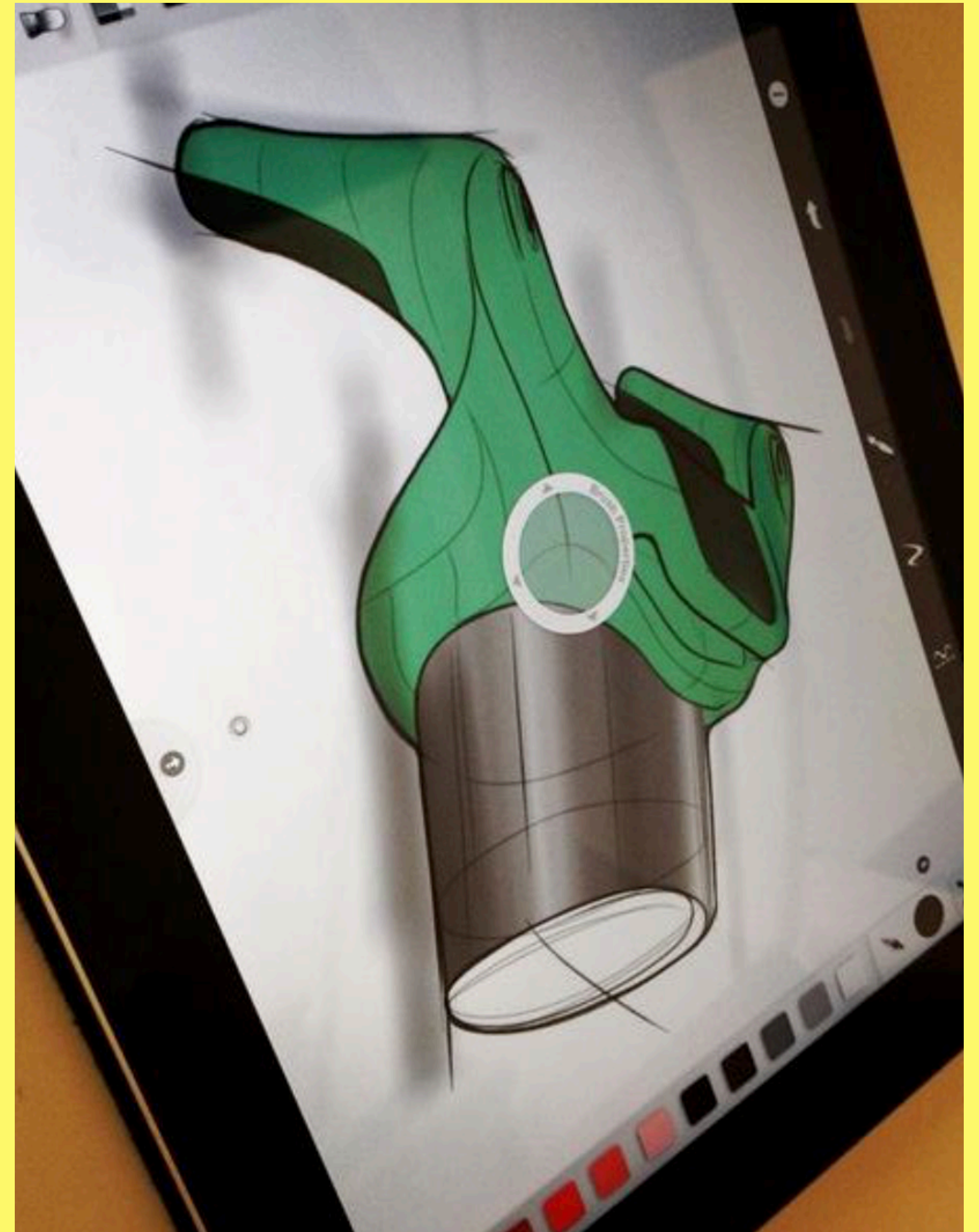



**Exercise 1**

# **Geometric Construction**

## **1st Perspective - Main View**

**20 Minutes**

SKETCHING

# **SURFACES - TENSION & FORCE**

Construction  
Basic Shapes

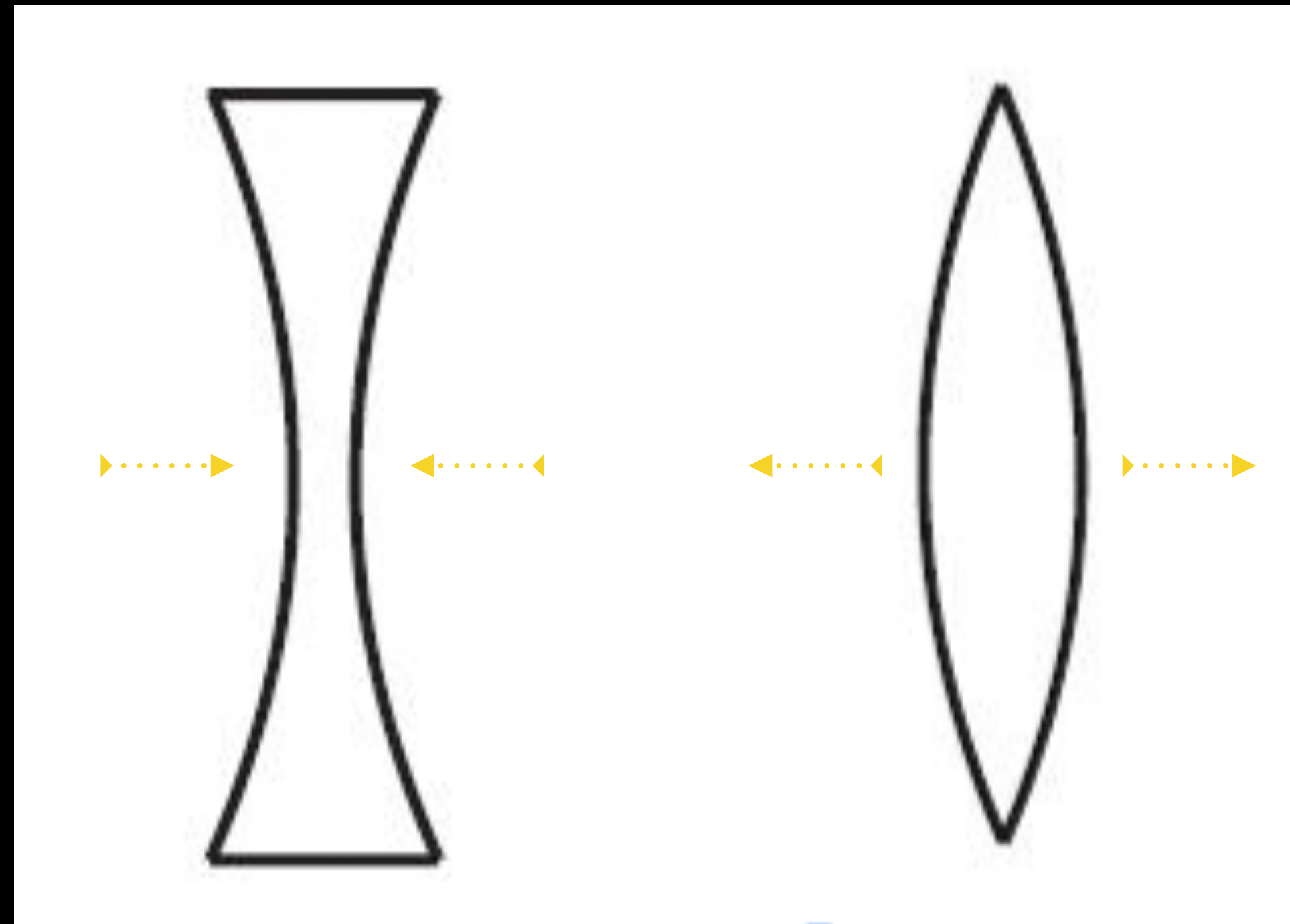
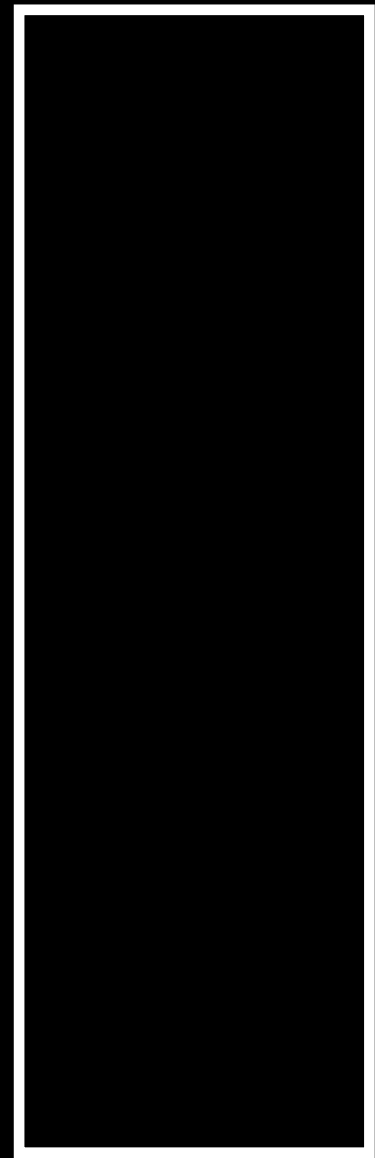

**Concave  
Surface**

**Convex  
Surface**

## Surfaces

## Directions & Force

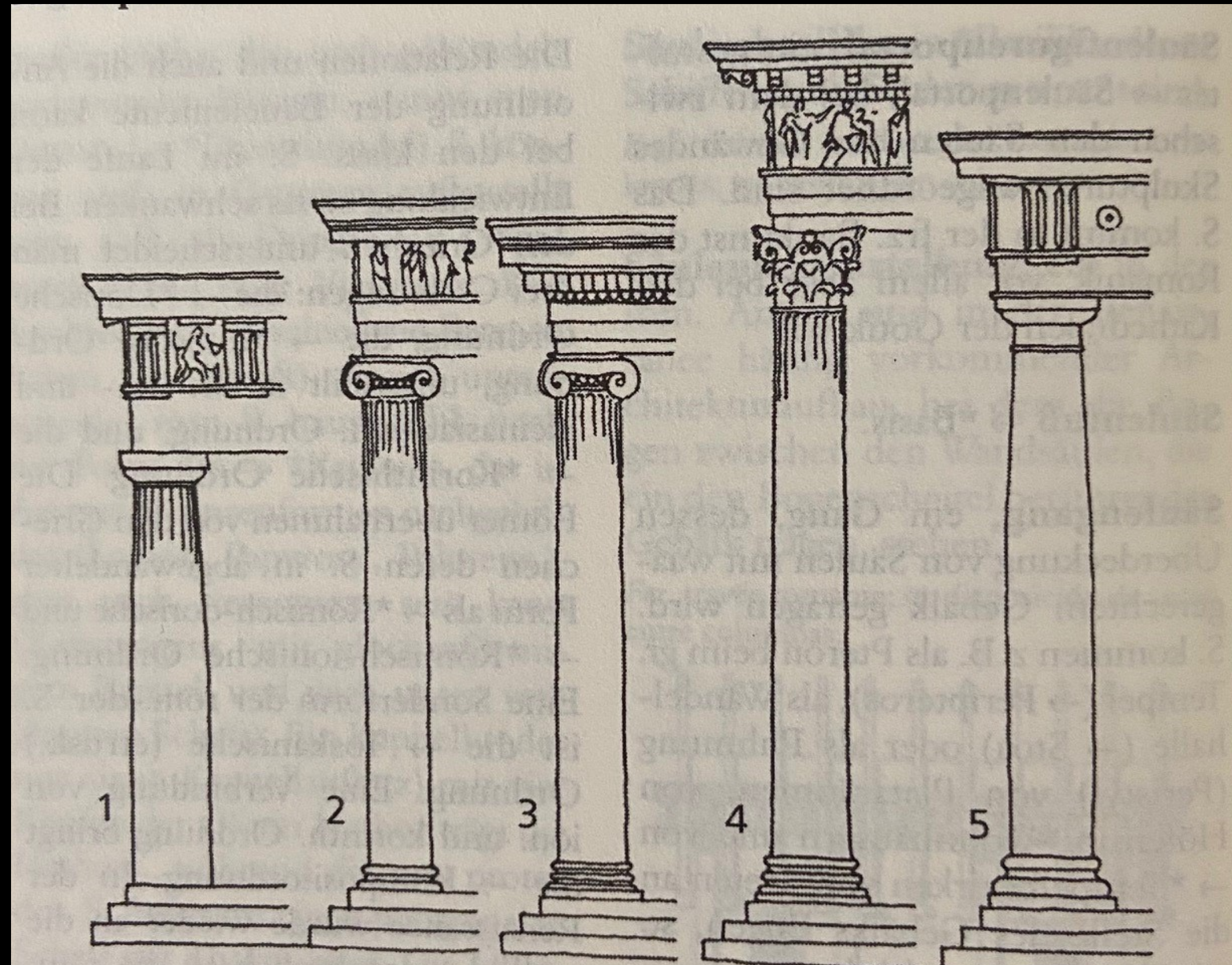

1. Dorische  
Säule

7.BC Greek

3. Ionische  
Säule

6.BC Roman

## Surfaces

# Ionic Column

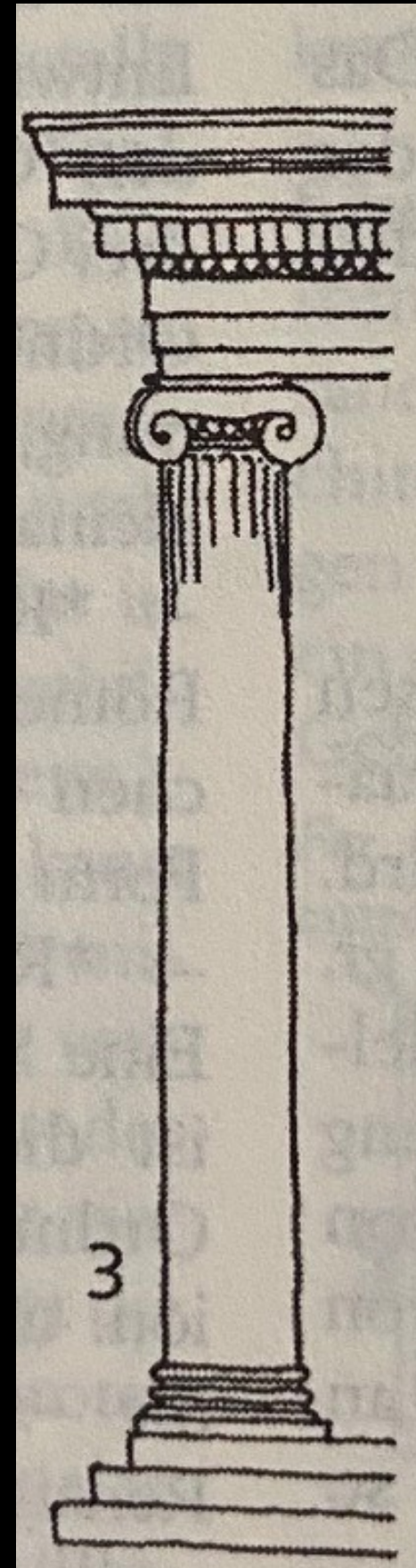

7.BC Greece



Apollon Temple  
Ionic Temple Didmya  
5. BC

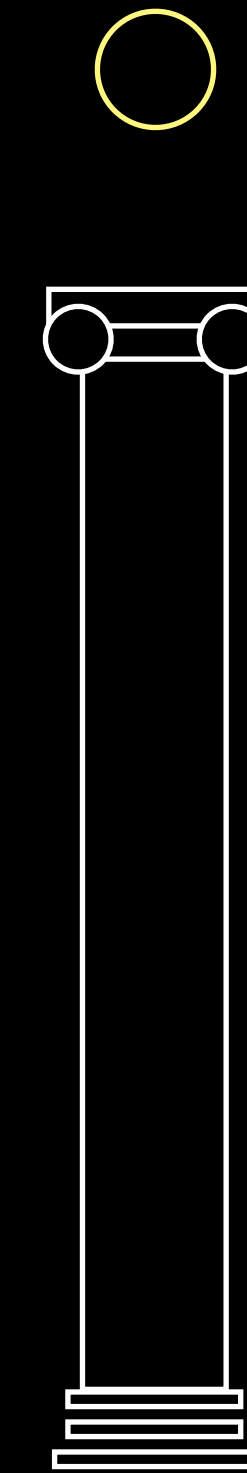

# Surfaces

## Doric Column

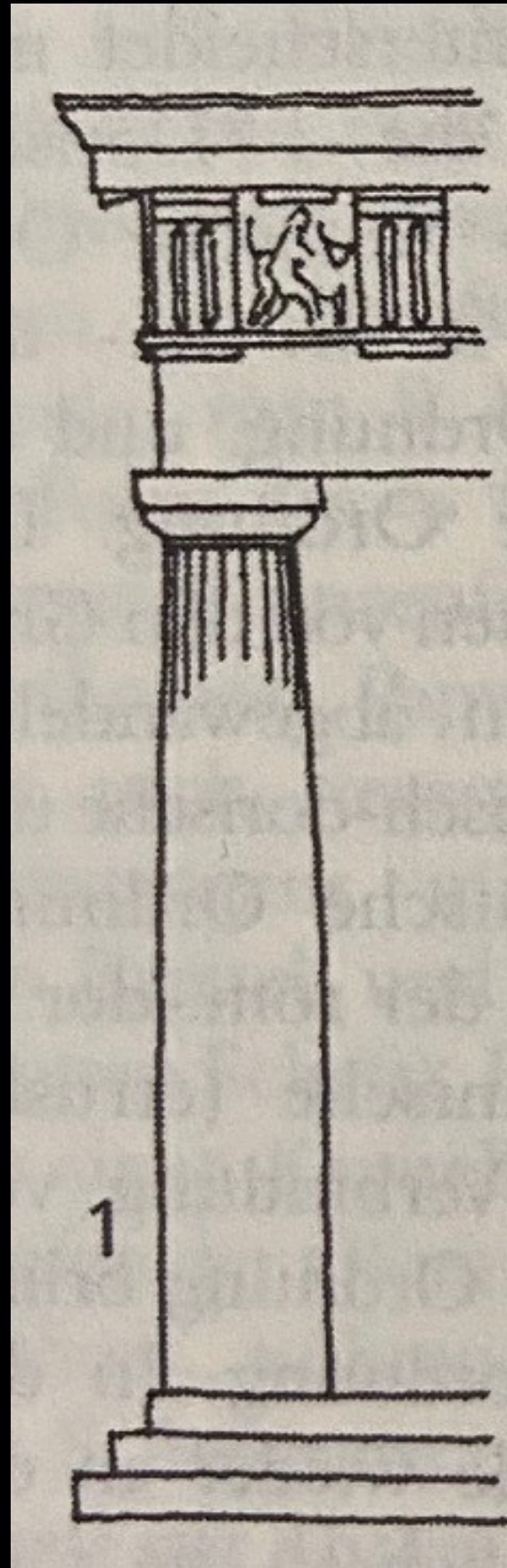

7.BC Greece



Temple of Poseidon  
Doric Temple Paestum  
„Magne Graecia“ 6. BC

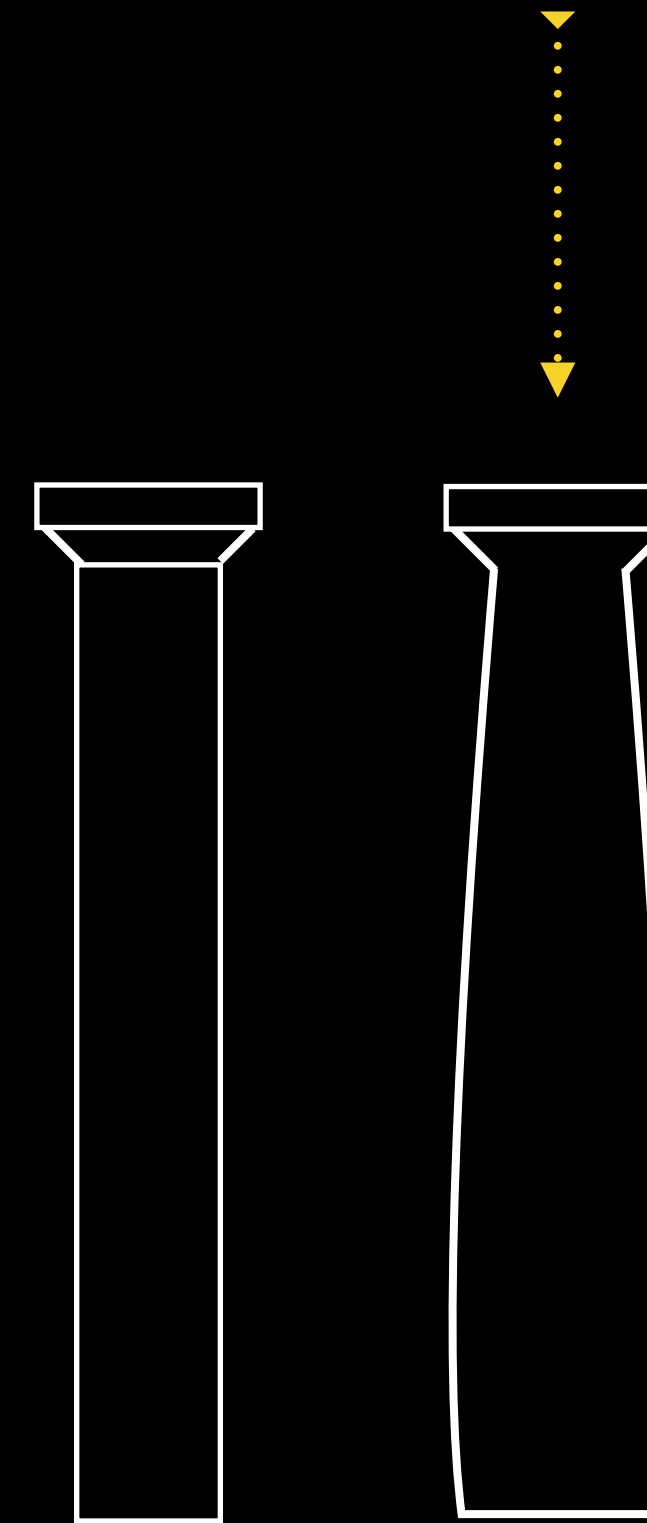

# Surfaces

## Directions & Force

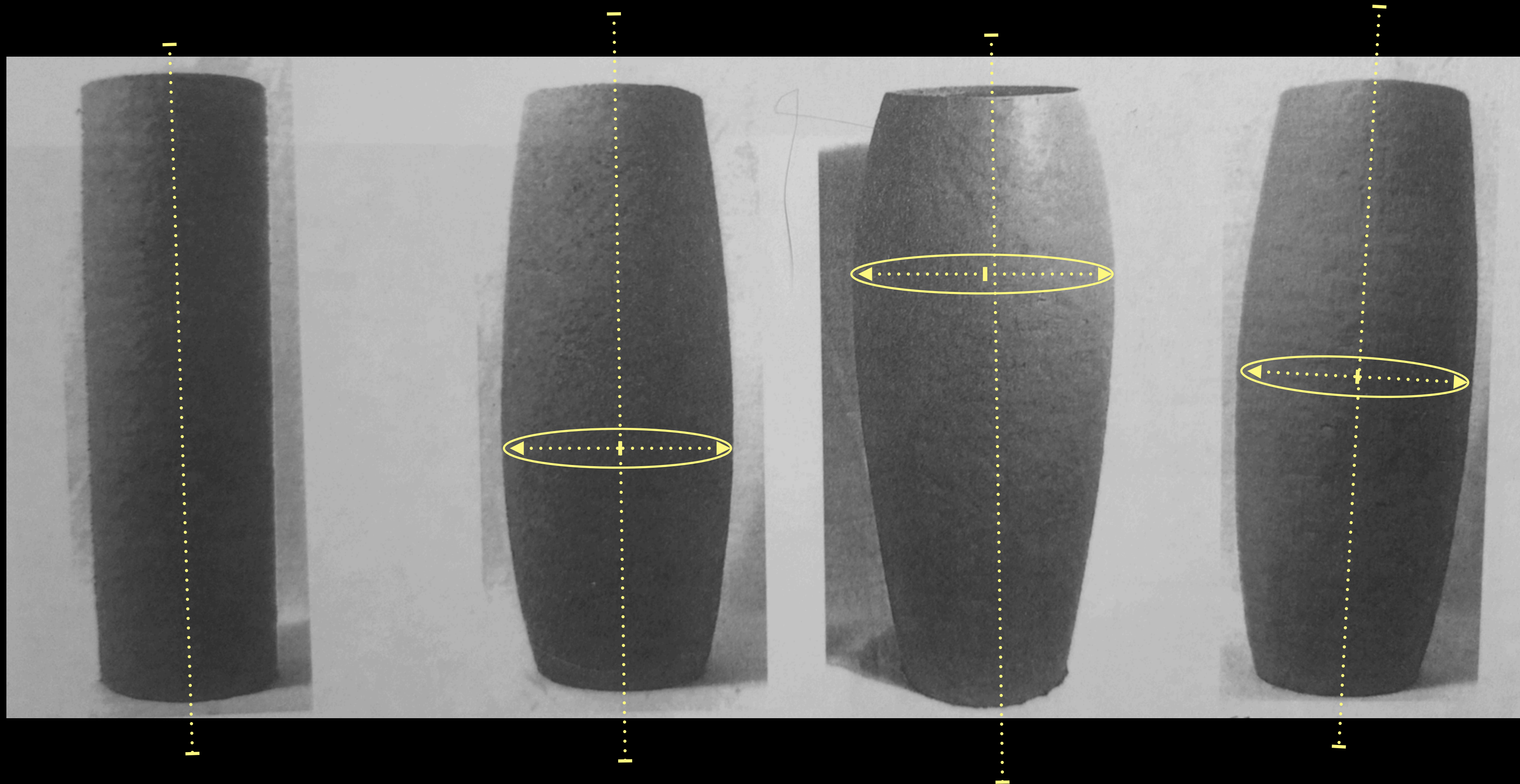

## Surfaces

### Directions & Force

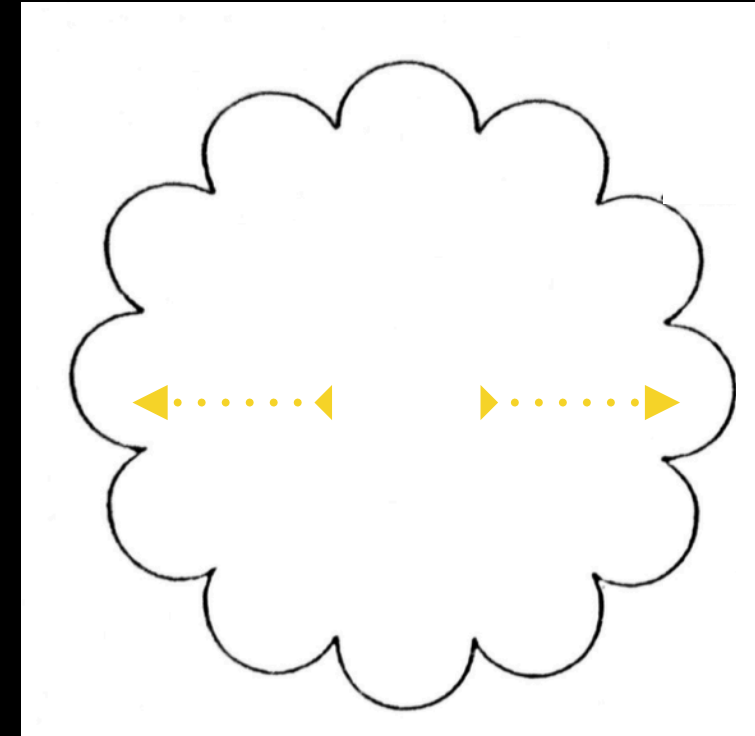

**Convex  
Surface**

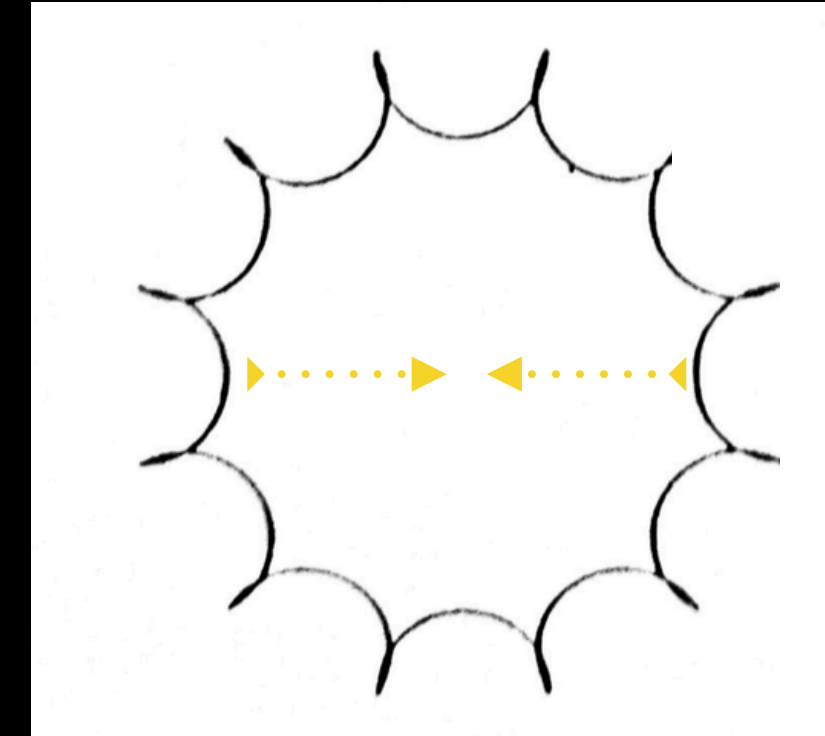

**Concave  
Surface**



**Rotating  
Surface**



Construction  
Forces & Tension

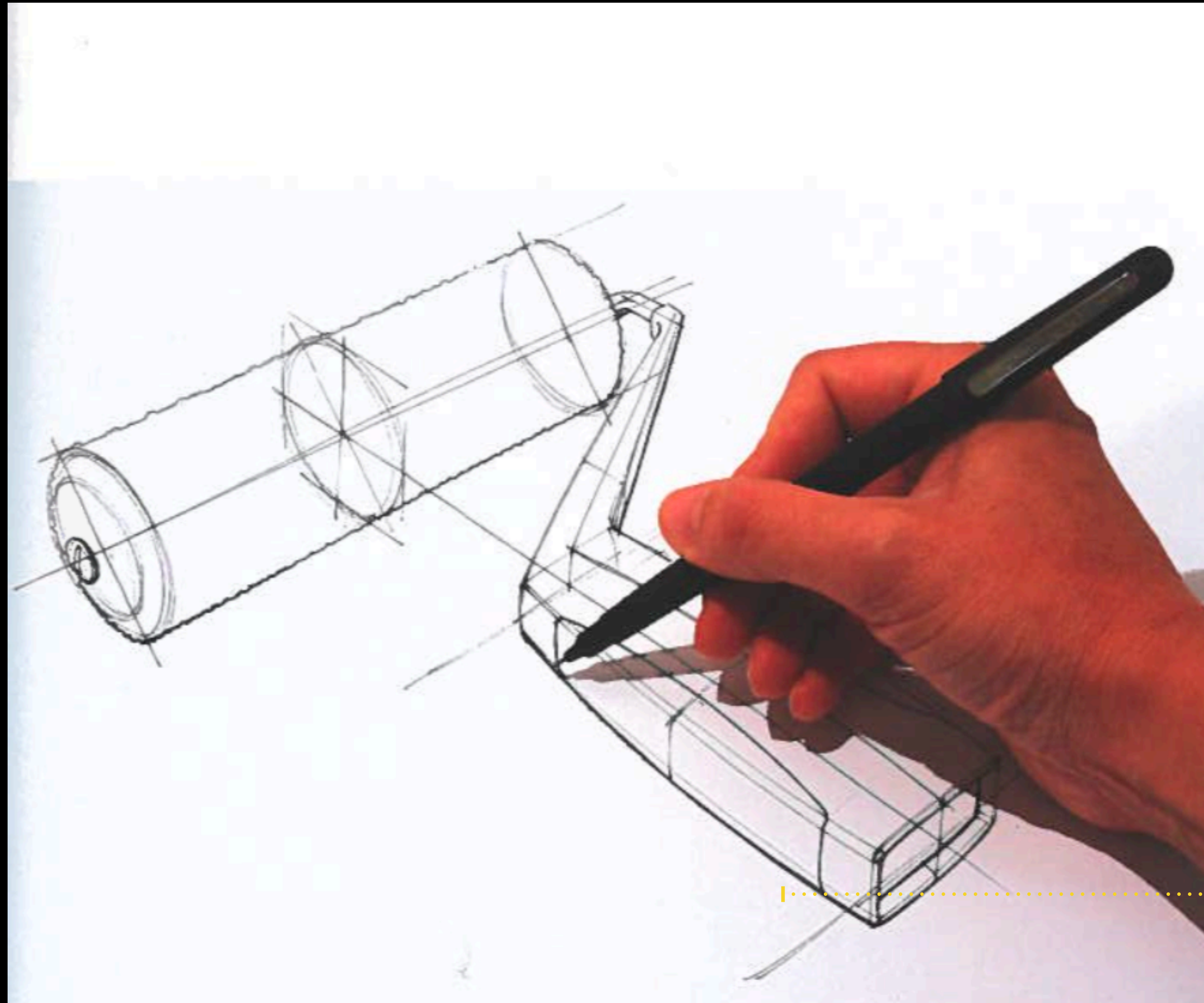

**Convex Surface**

**COFFEE BREAK!**

Exercise 2

# Curves

**2nd Perspective - Pay attention  
to the direction of force on the  
object**

Construction

# SHAPE DEVELOPMENT



Construction

# SHAPE DEVELOPMENT

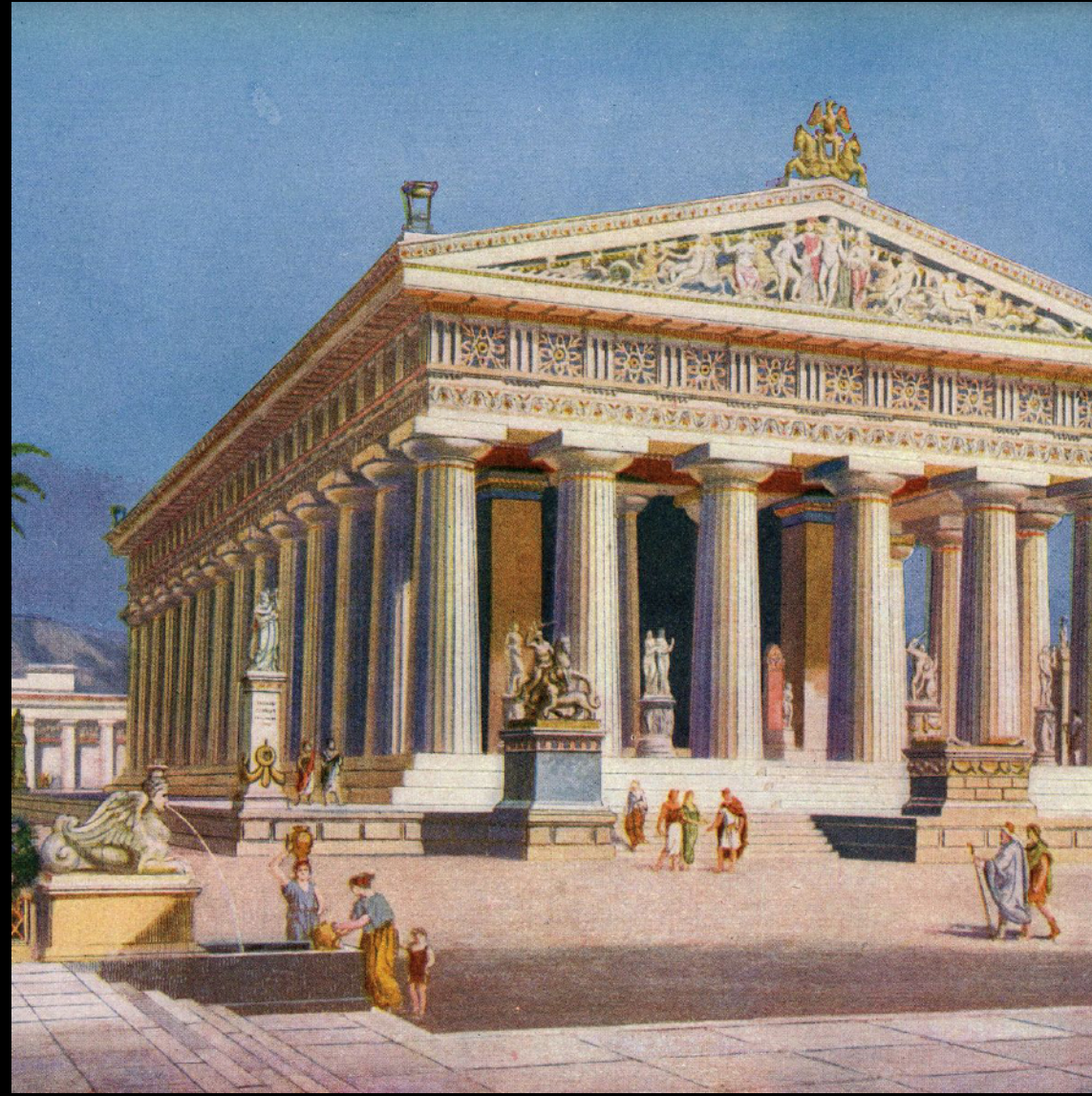

Construction

# SHAPE DEVELOPMENT



SKETCHING

**SHADOWS**

Construction  
**SHADOWS**

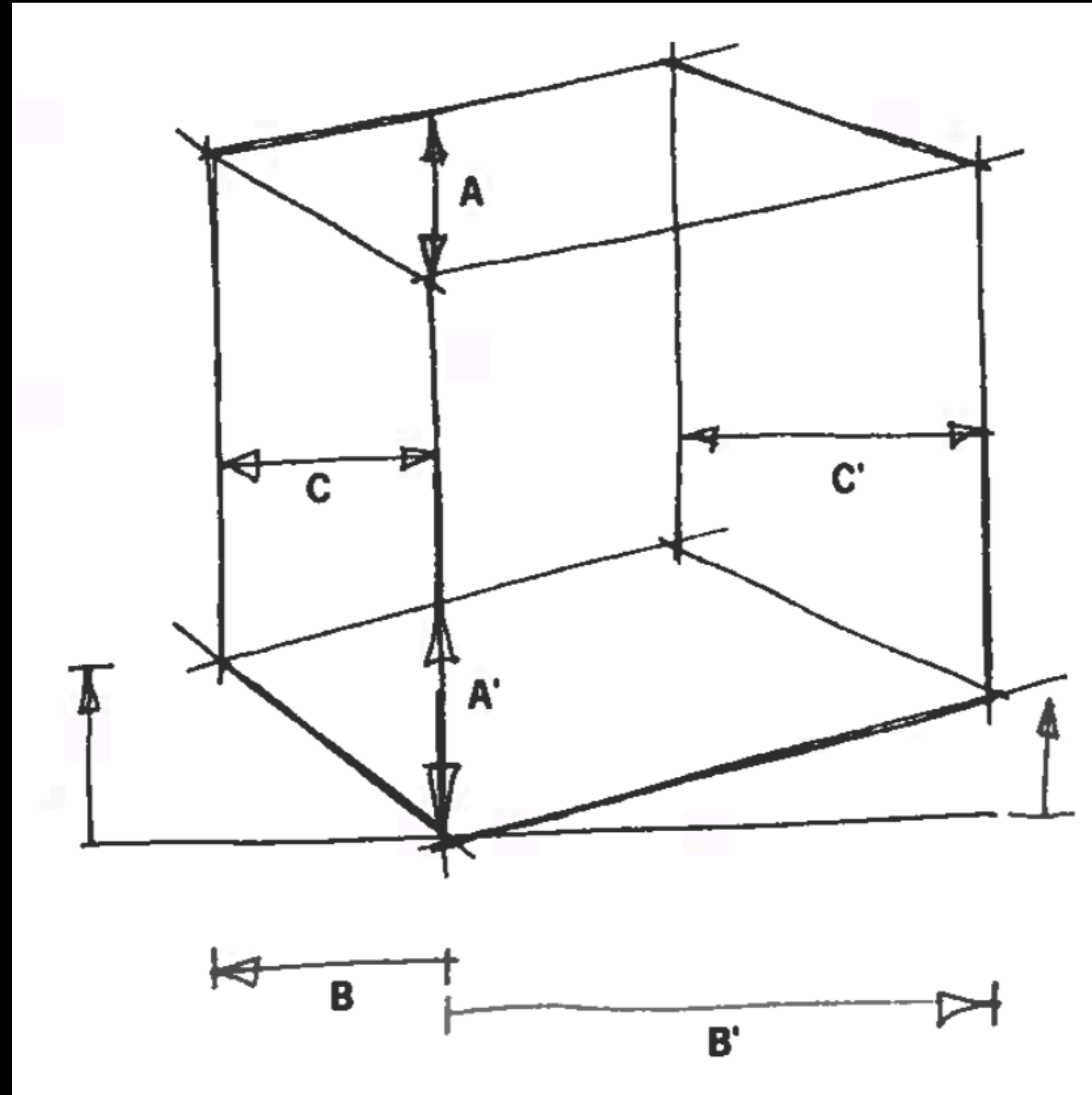



# Construction SHADOWS

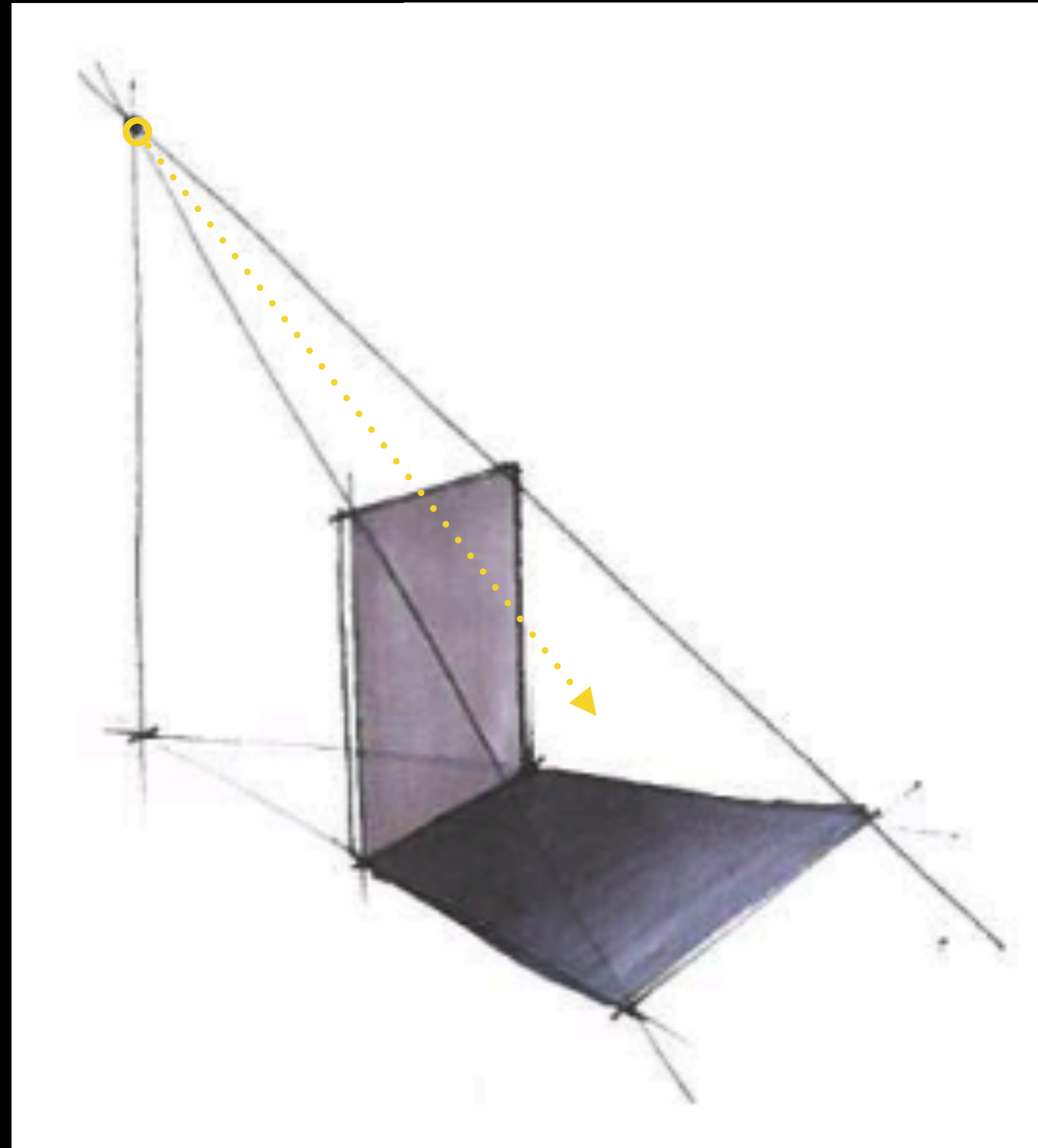

# Construction SHADOWS

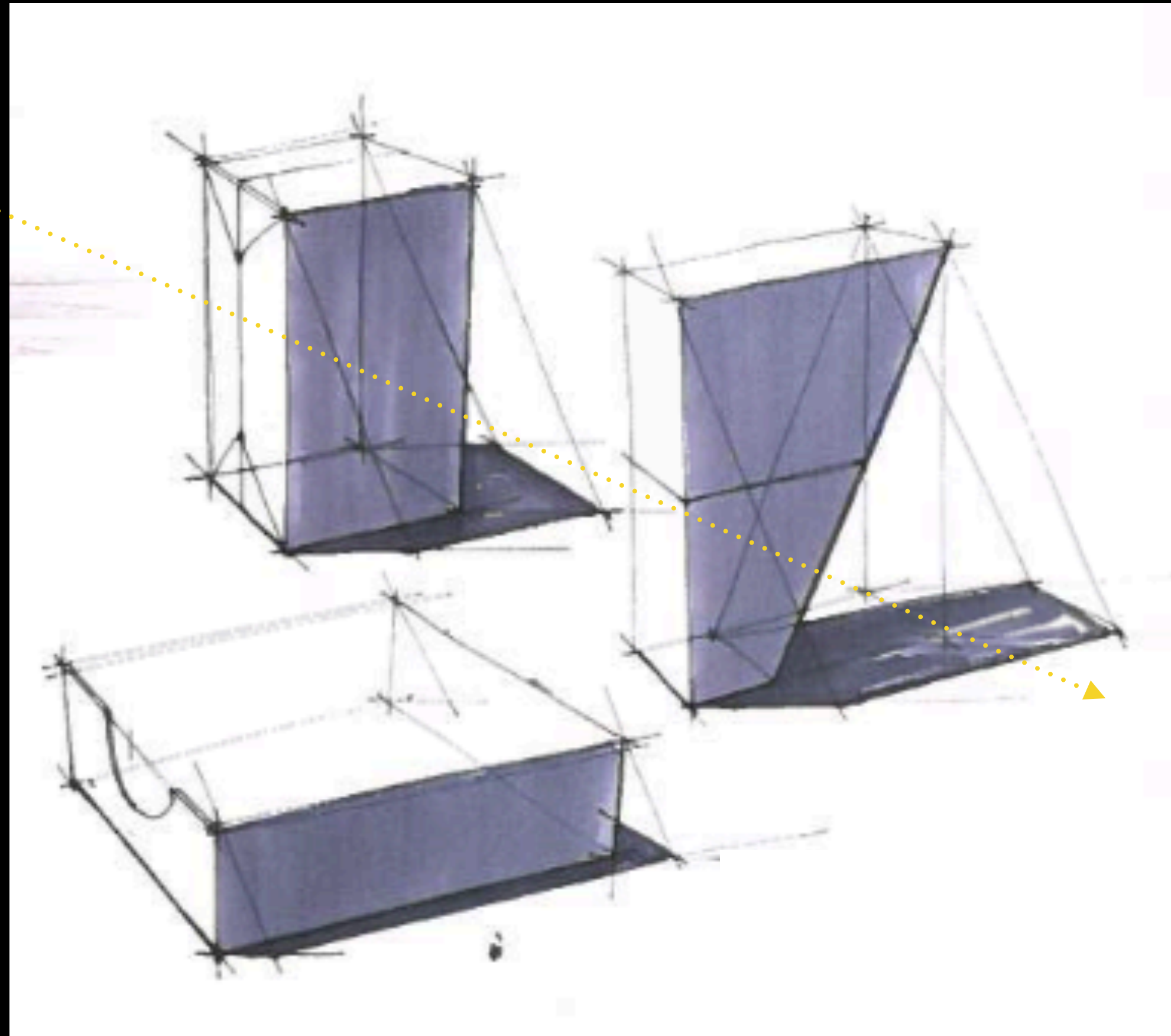

# Construction SHADOWS

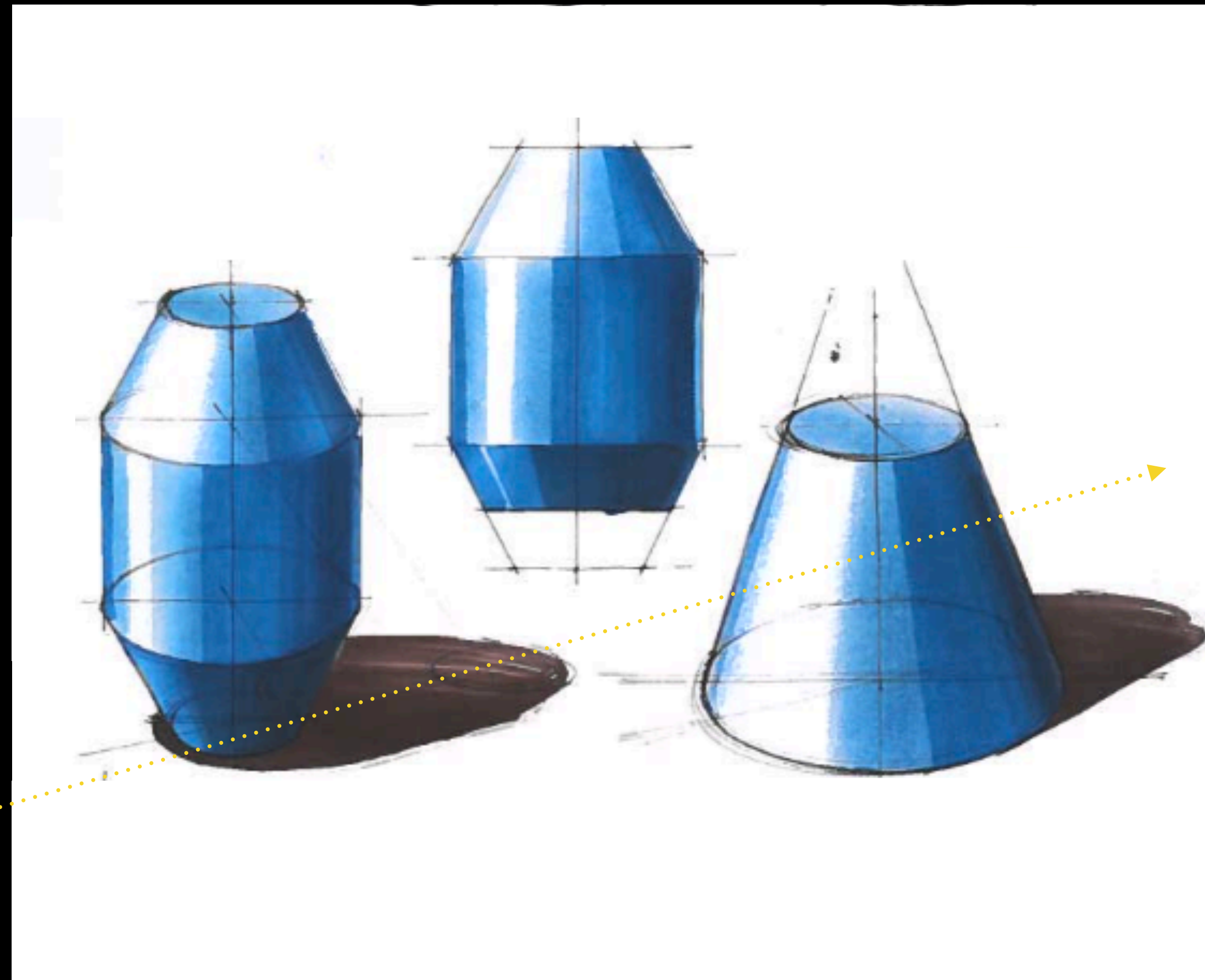

# Construction SHADOWS

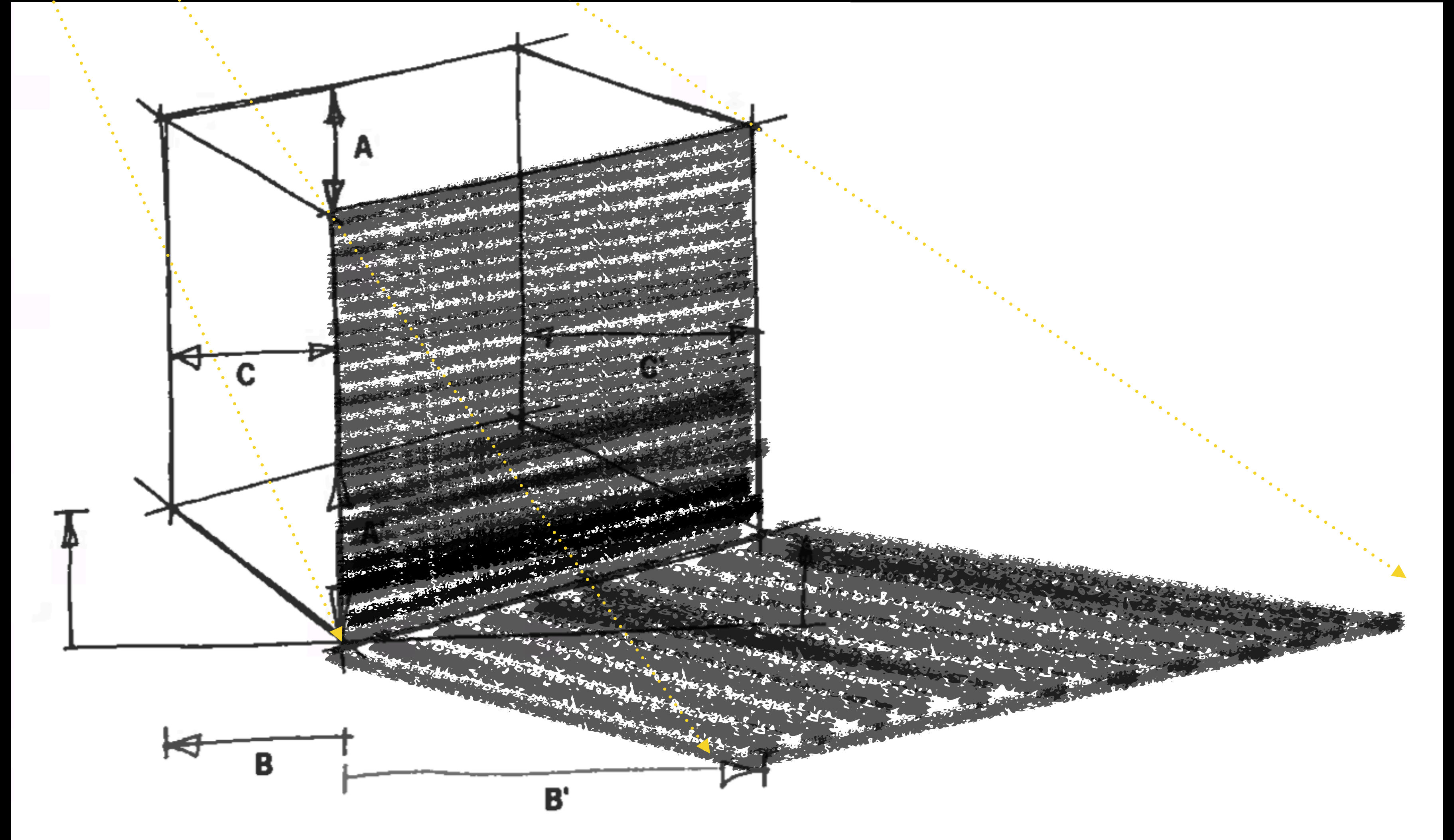

# Construction SHADOWS

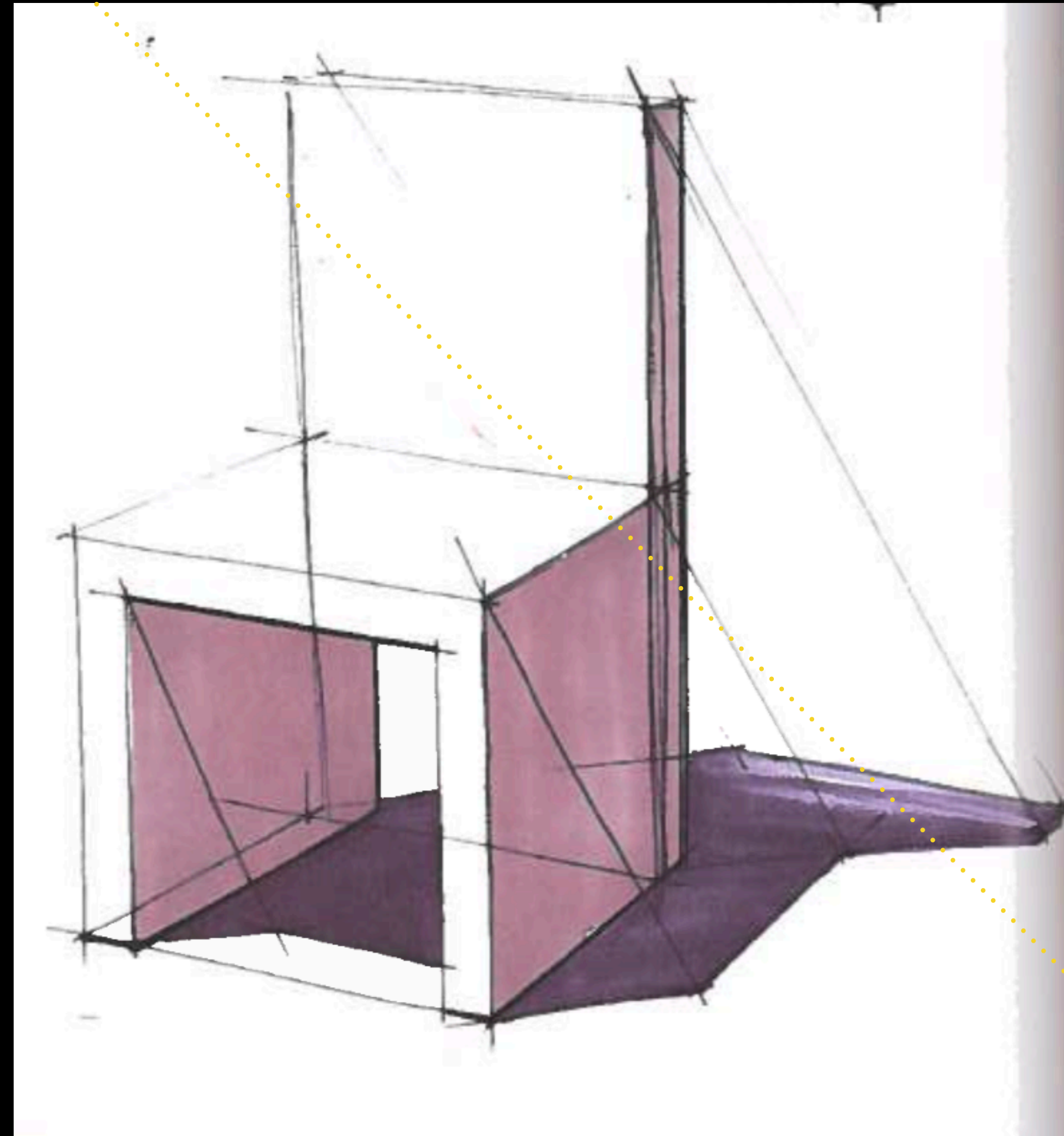

Construction  
**SHADOWS**



Construction  
**SHADOWS**

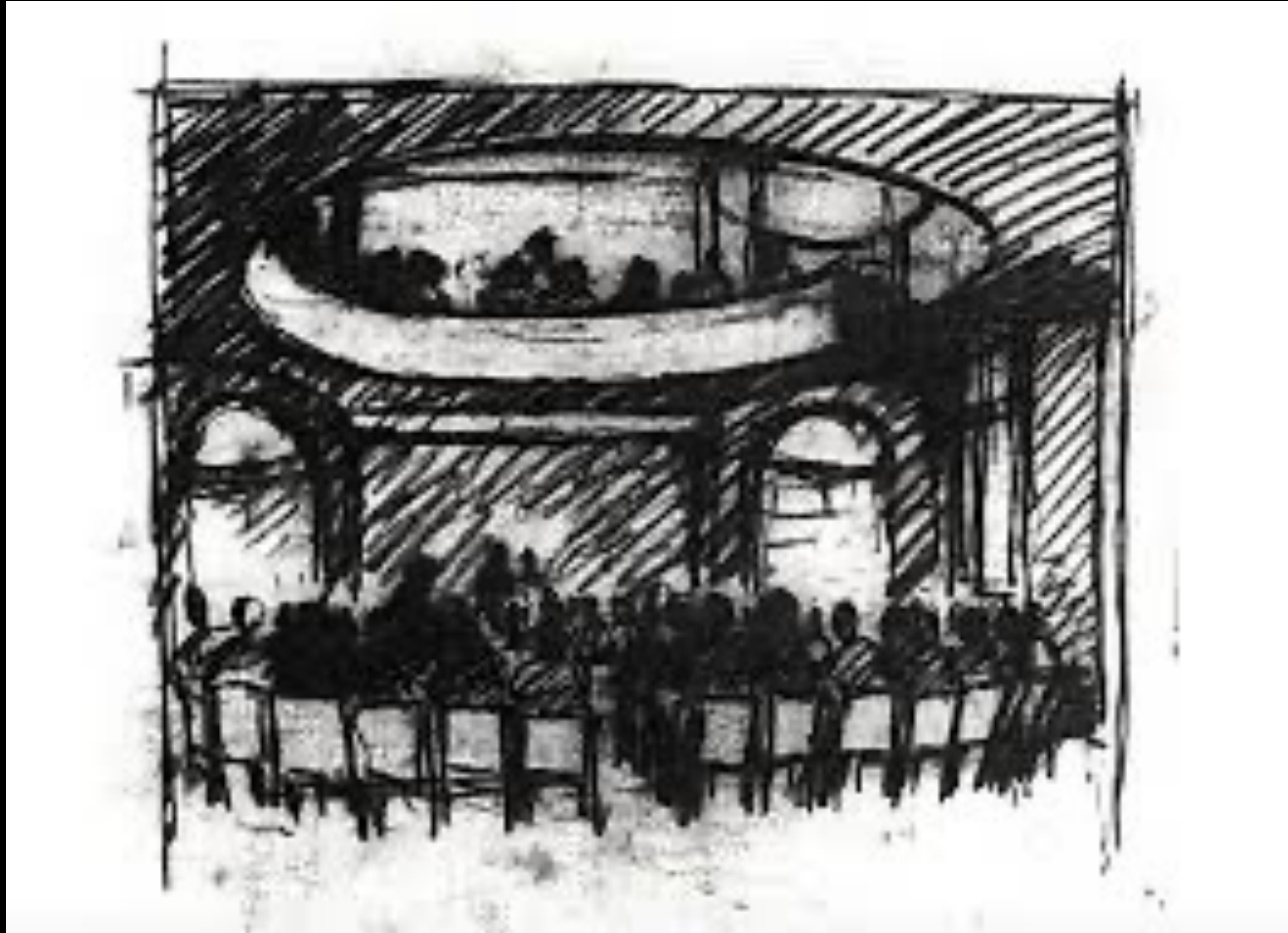

Exercise 3

# Shadowing

**2nd Perspective - Pay attention  
to the direction shadows**



SKETCHING

**SECTIONS**

Construction  
**SECTIONS**

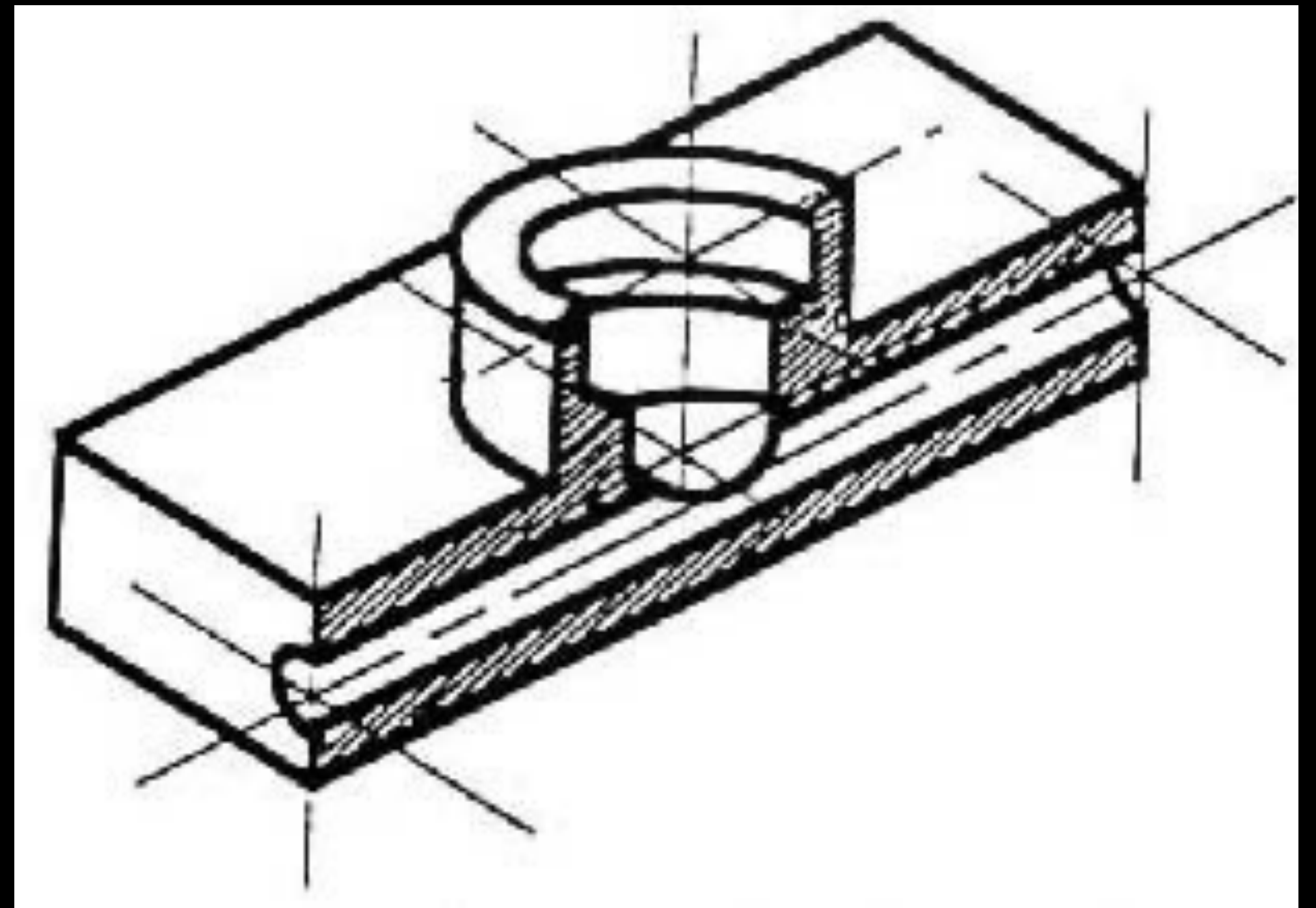
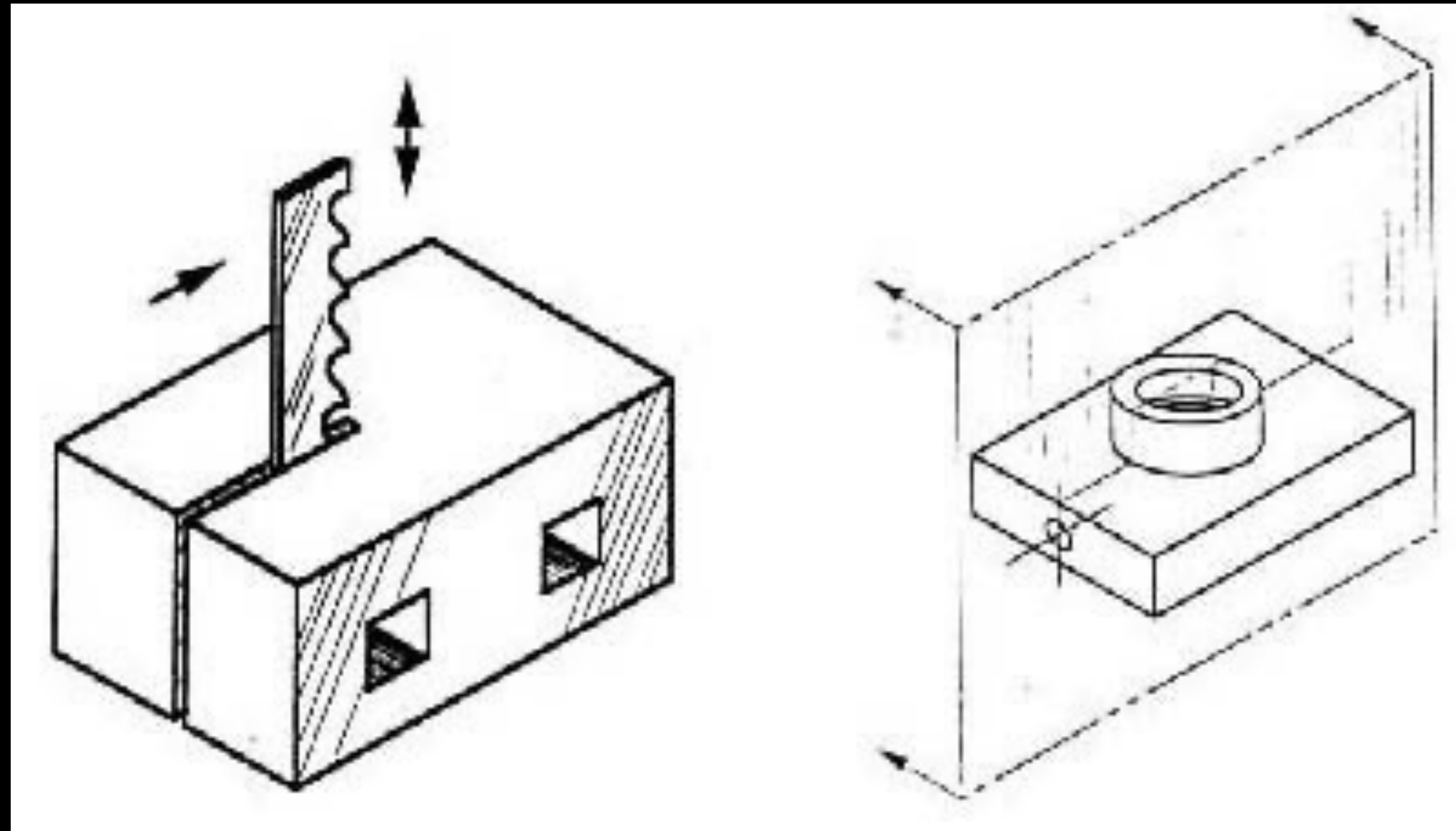

# Construction SECTIONS

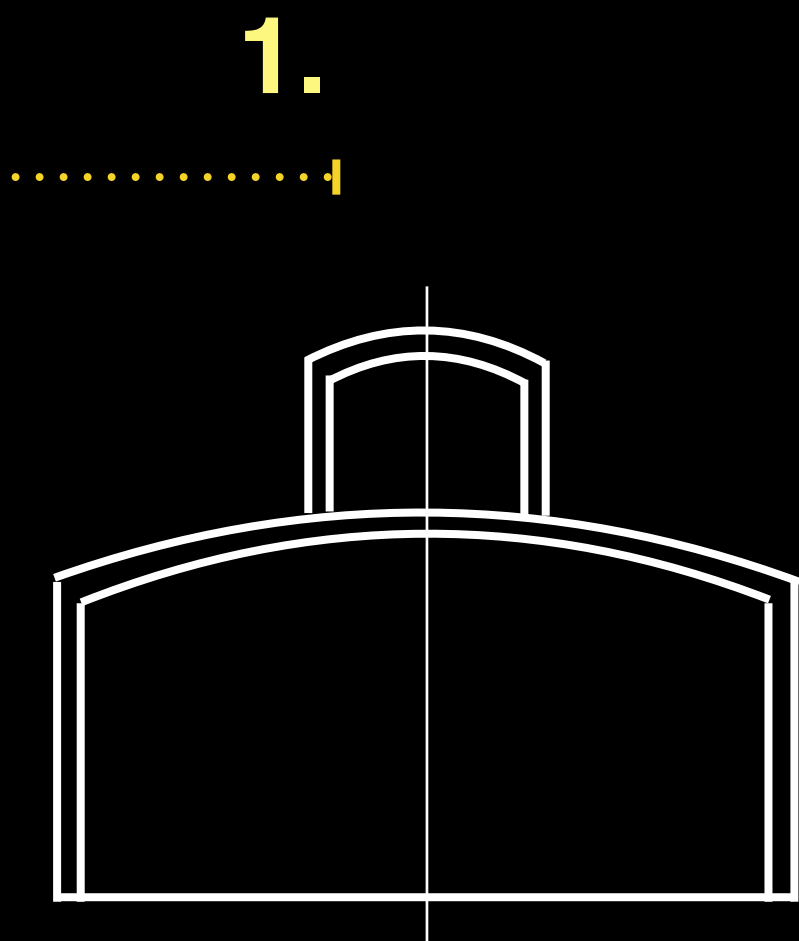
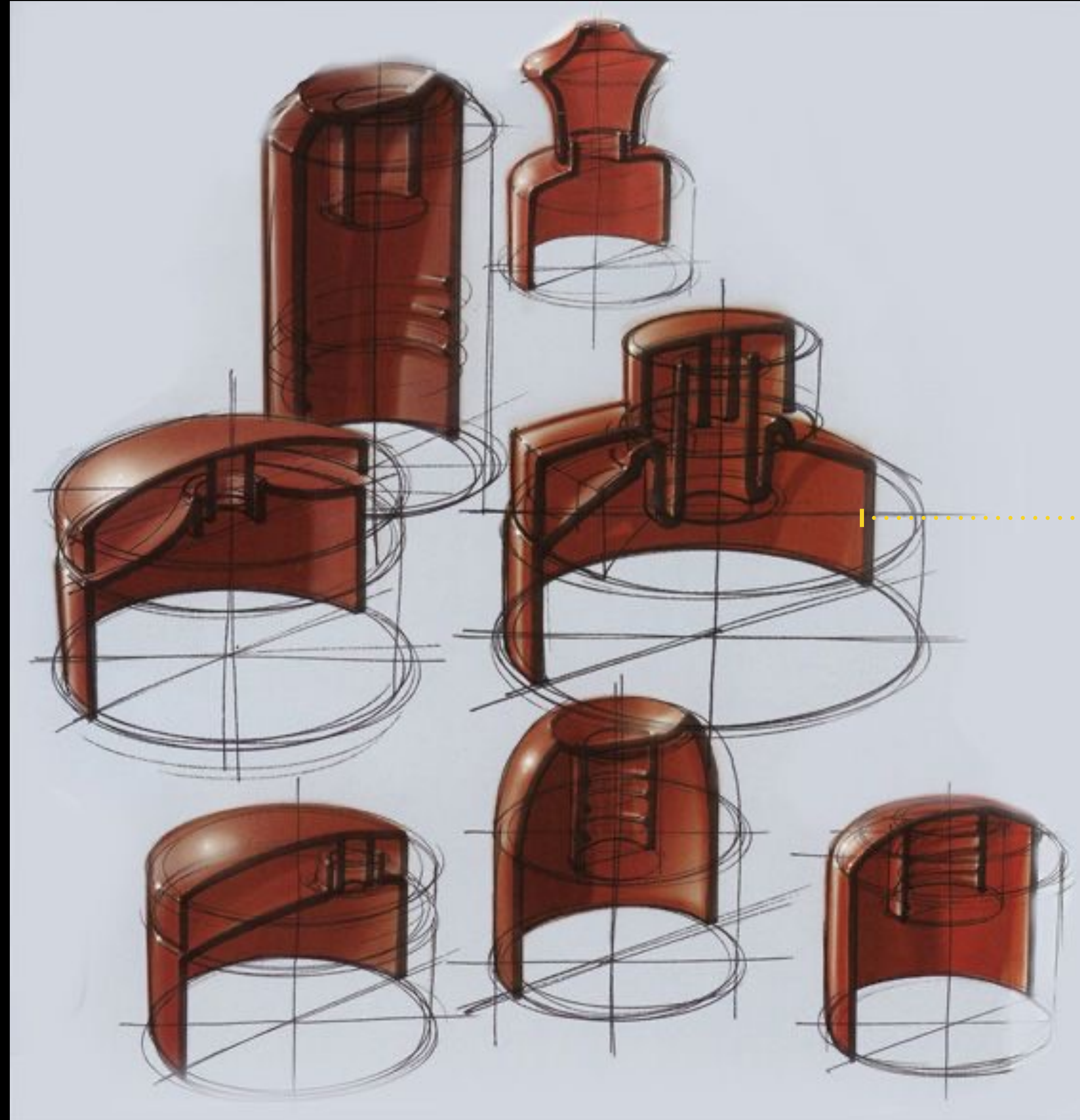

**Exercise 4**

**1 minute Sections**

**Sketch three objects to cut  
through**

**3 Minutes**

SKETCHING

# FOCAL POINT

# Construction Strokes

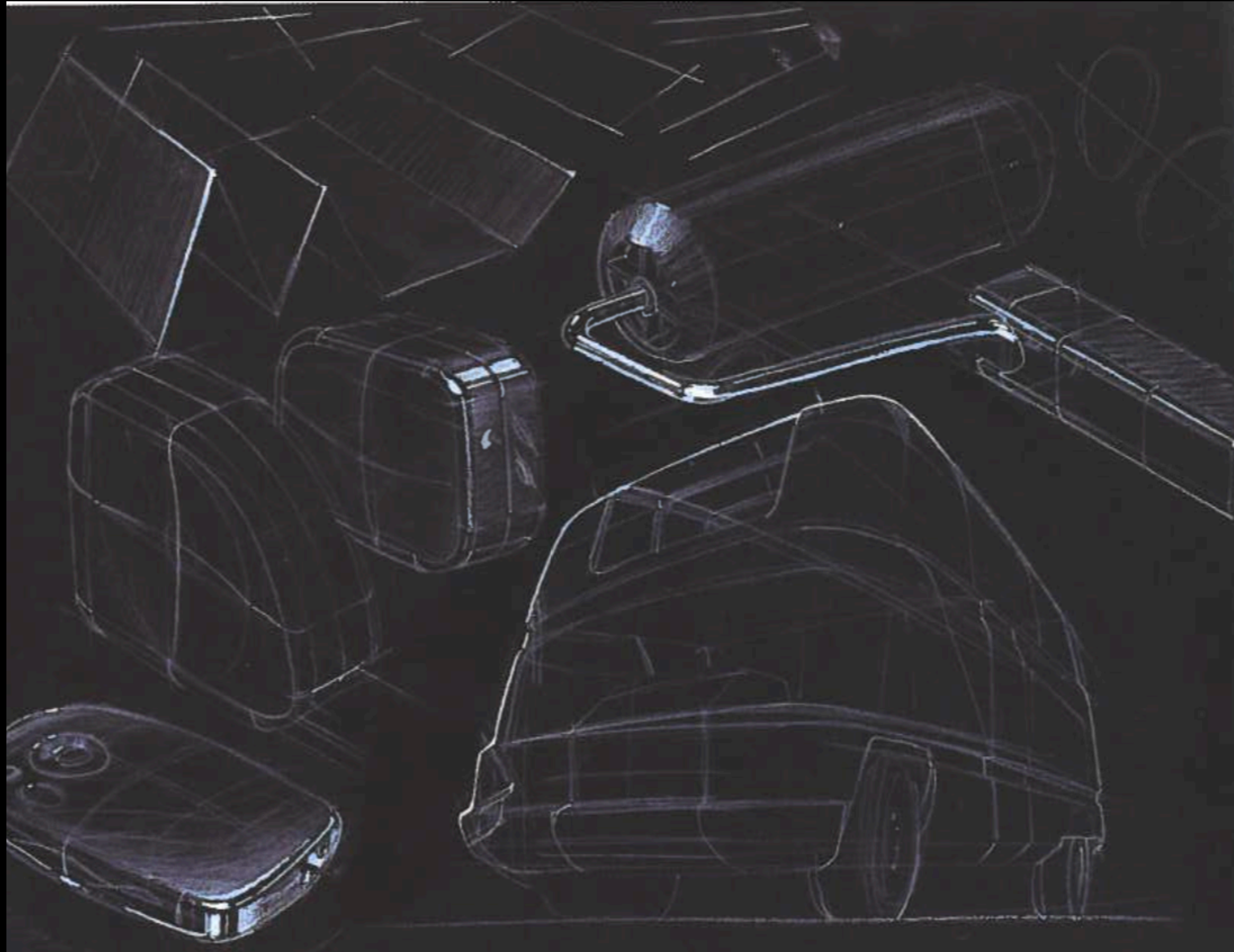

# Construction Coloring



# Construction Focal Points

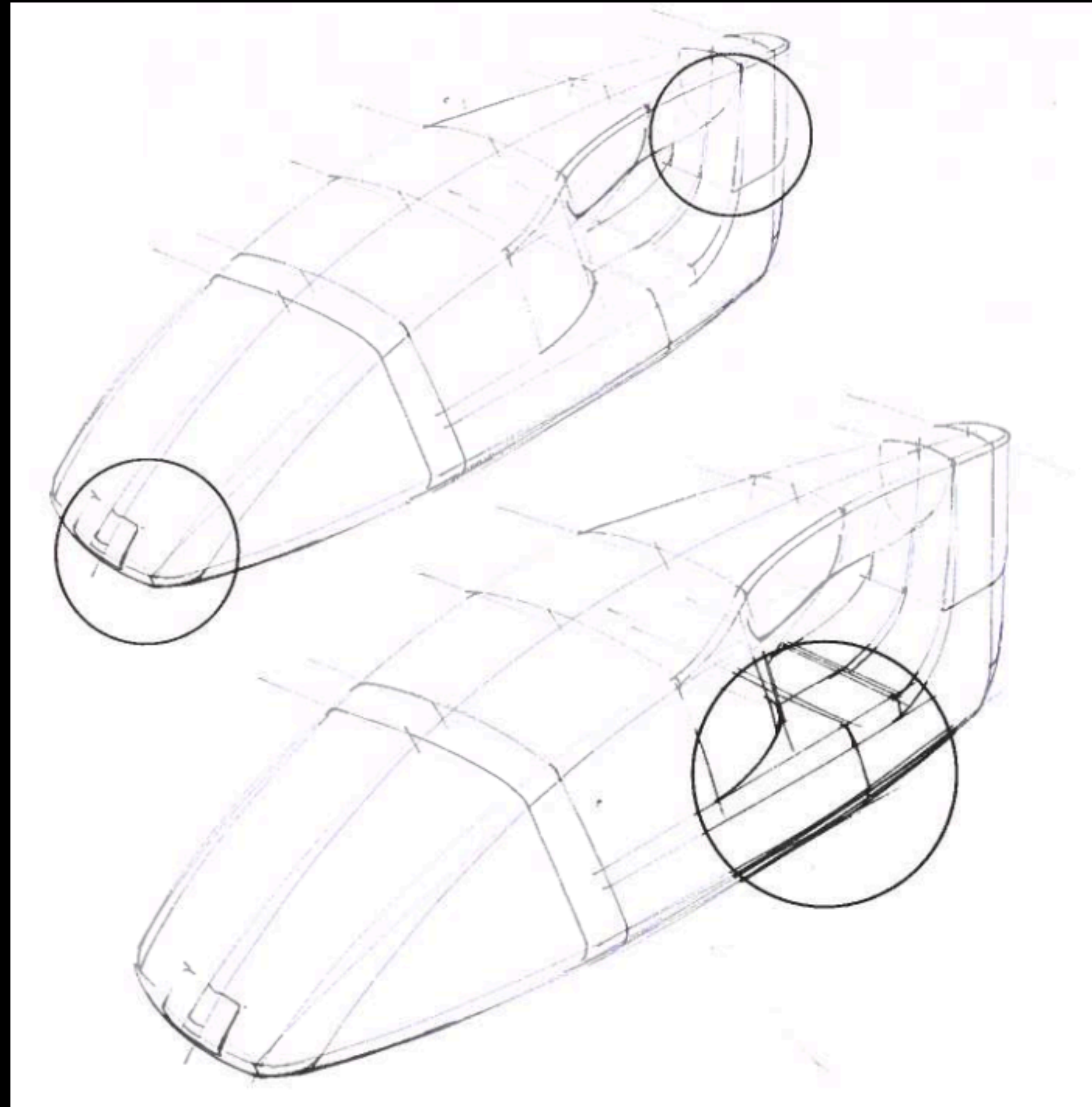



SKETCHING

**COLORING**

# Highlight Light

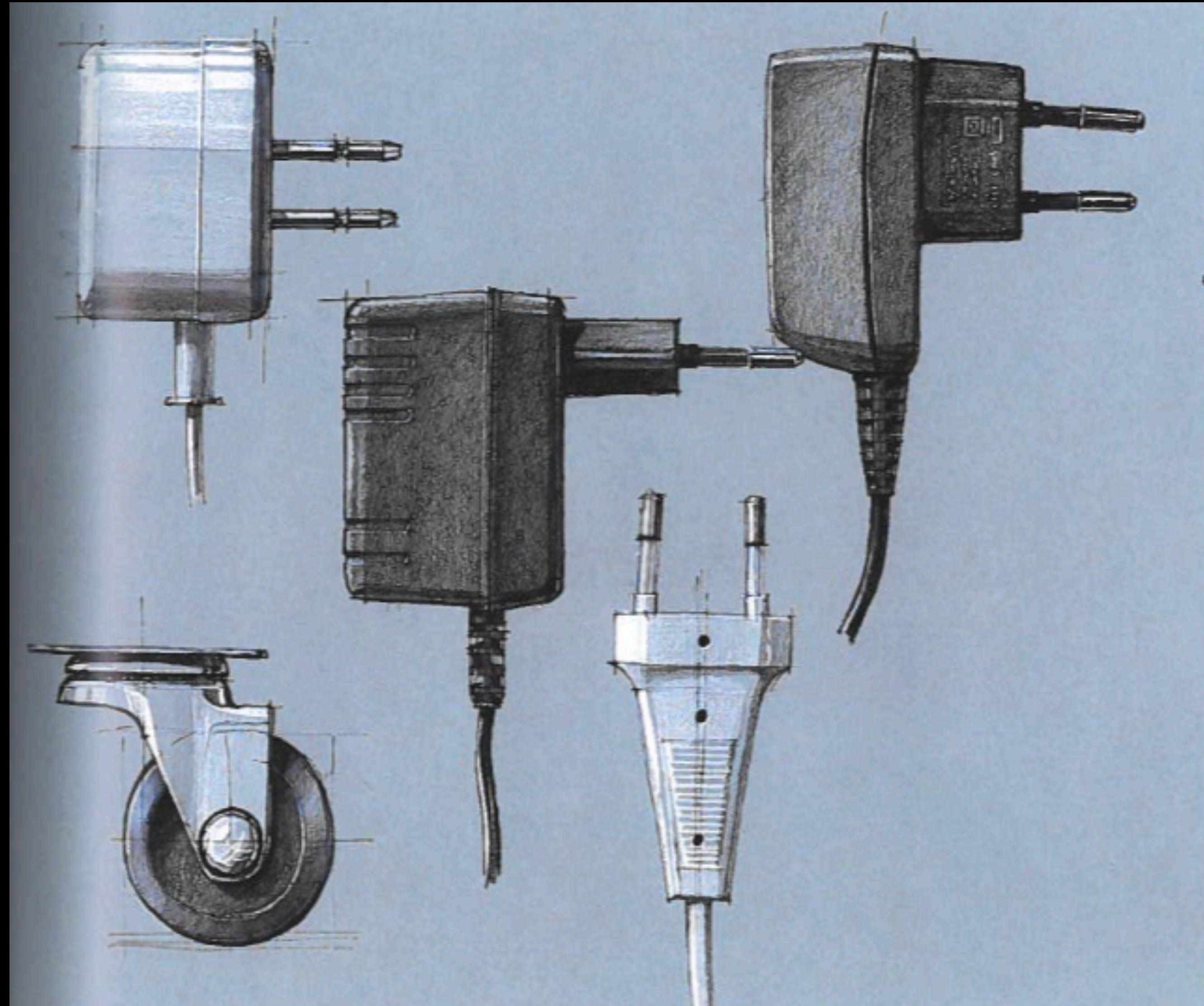

**Highlight**  
**Selected Coloring**

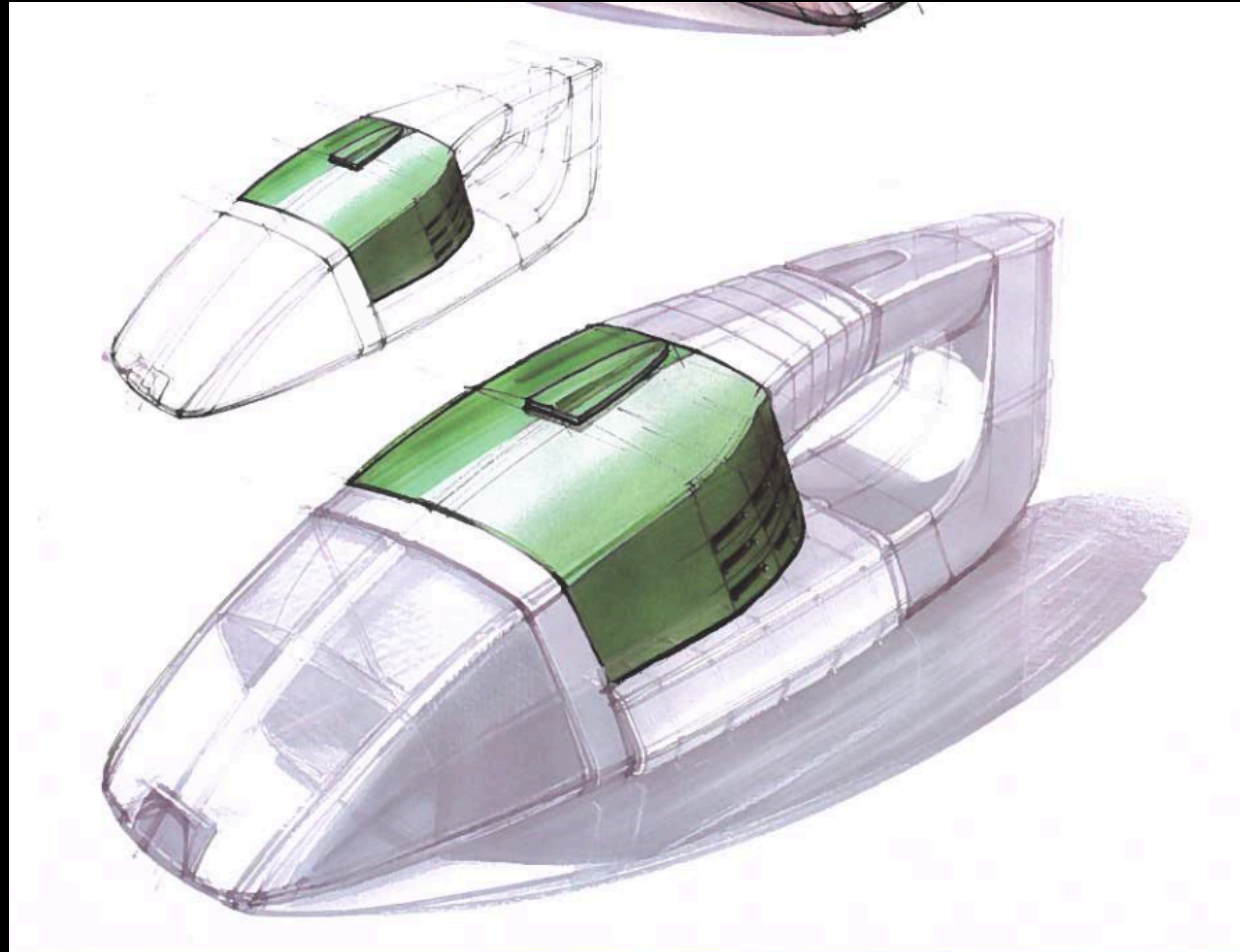

# Highlight Colored Background

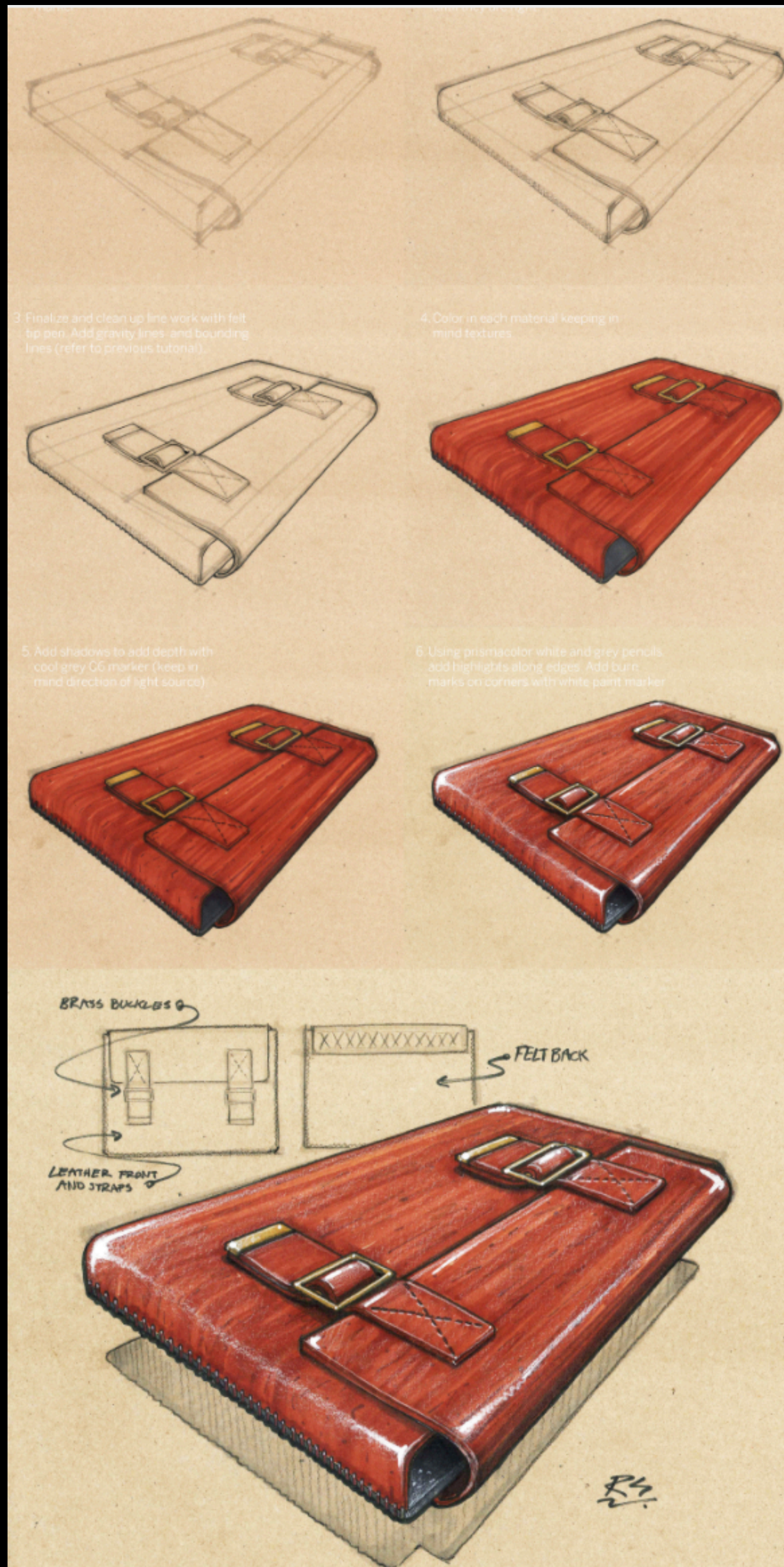

Highlight

The right personal portion and style

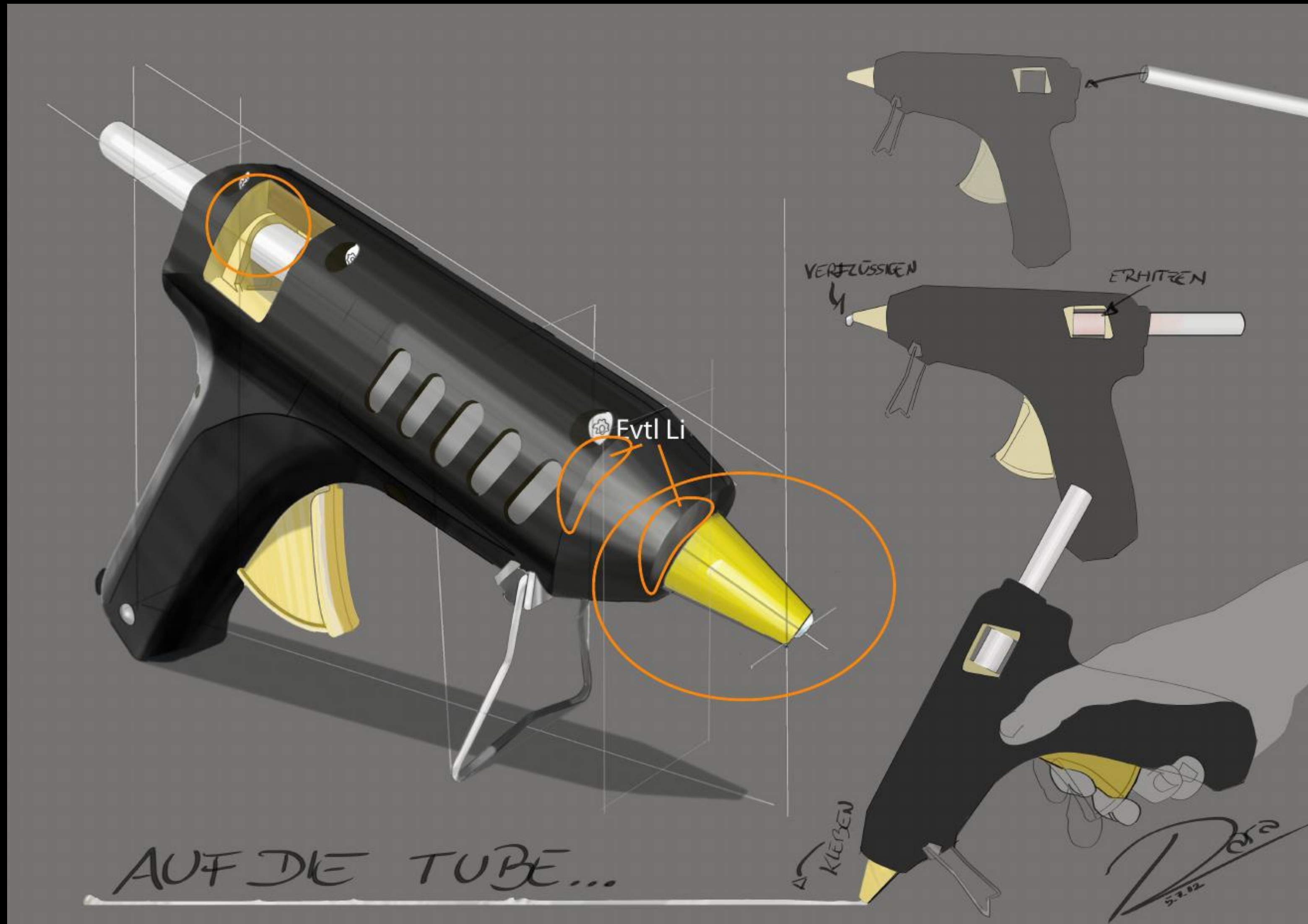

# Highlight Color as Expression

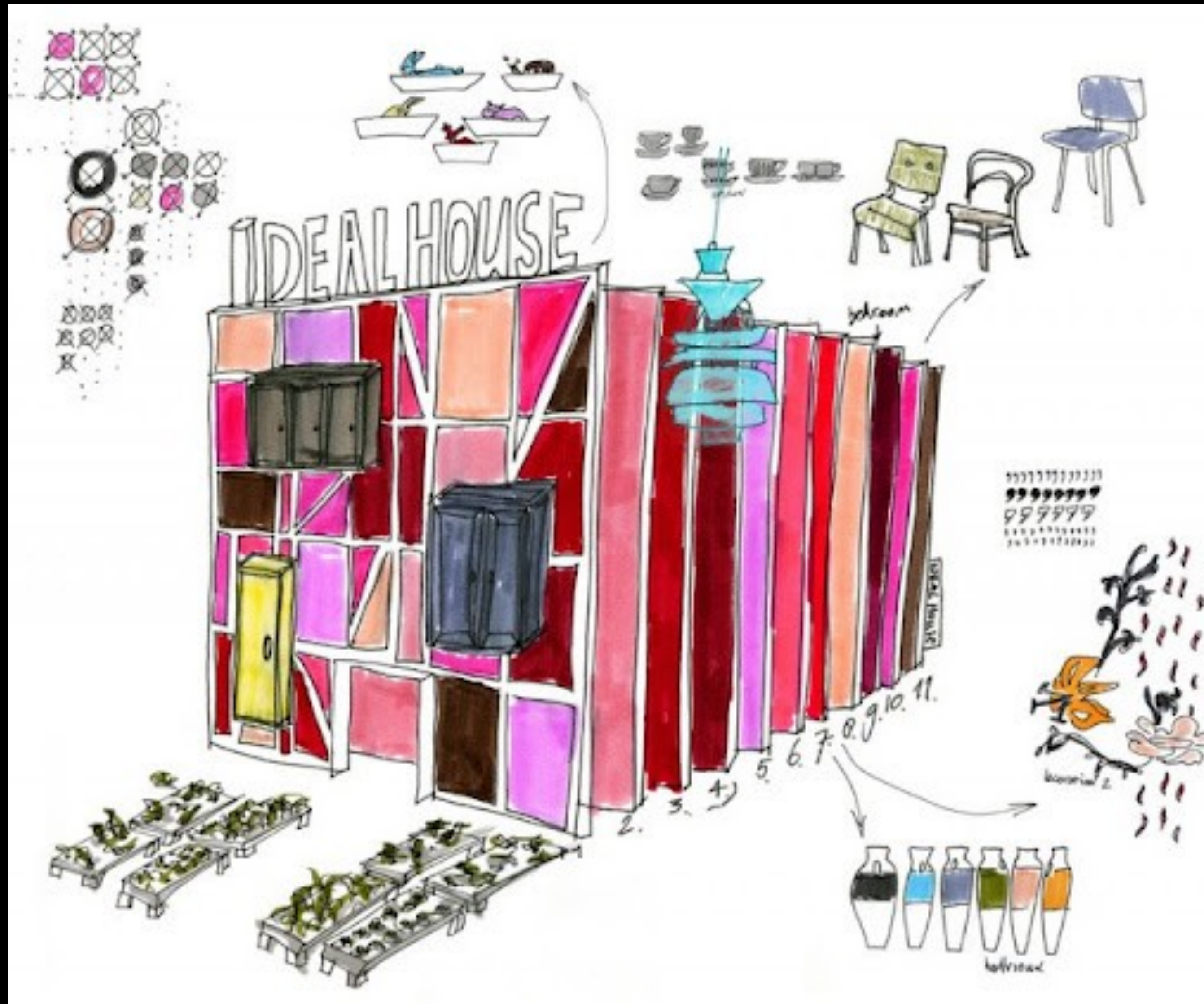

Hella Jongerius,  
„Ideal House“, 2005.

Highlight  
Color as Shape

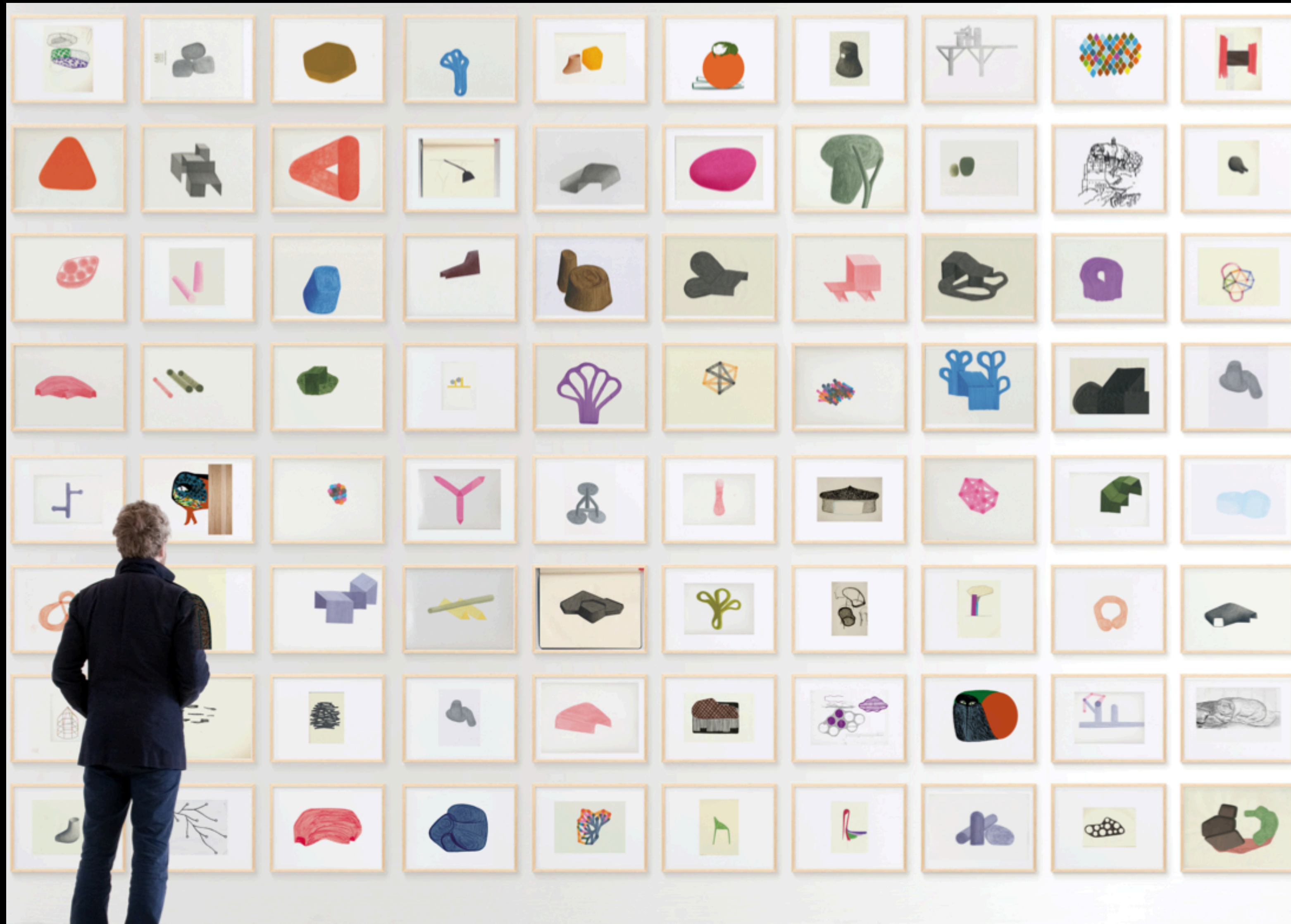

Ronan and Erwan  
Bouroullec, „Album“,  
2013.

**Highlight**  
**Color as Shape**



**Ronan Bouroullec.**



Exercise 9

# Coloring

# Start Coloring a Sketch!

Exercise 7

# **Strokes & Focal Point**

**3rd Perspective - Pay attention  
to thickness of lines and focal  
points**

SKETCHING

# **FUNCTIONS / NOTES / ARROWS**

Construction

FUNCTION / NOTES / ARROWS

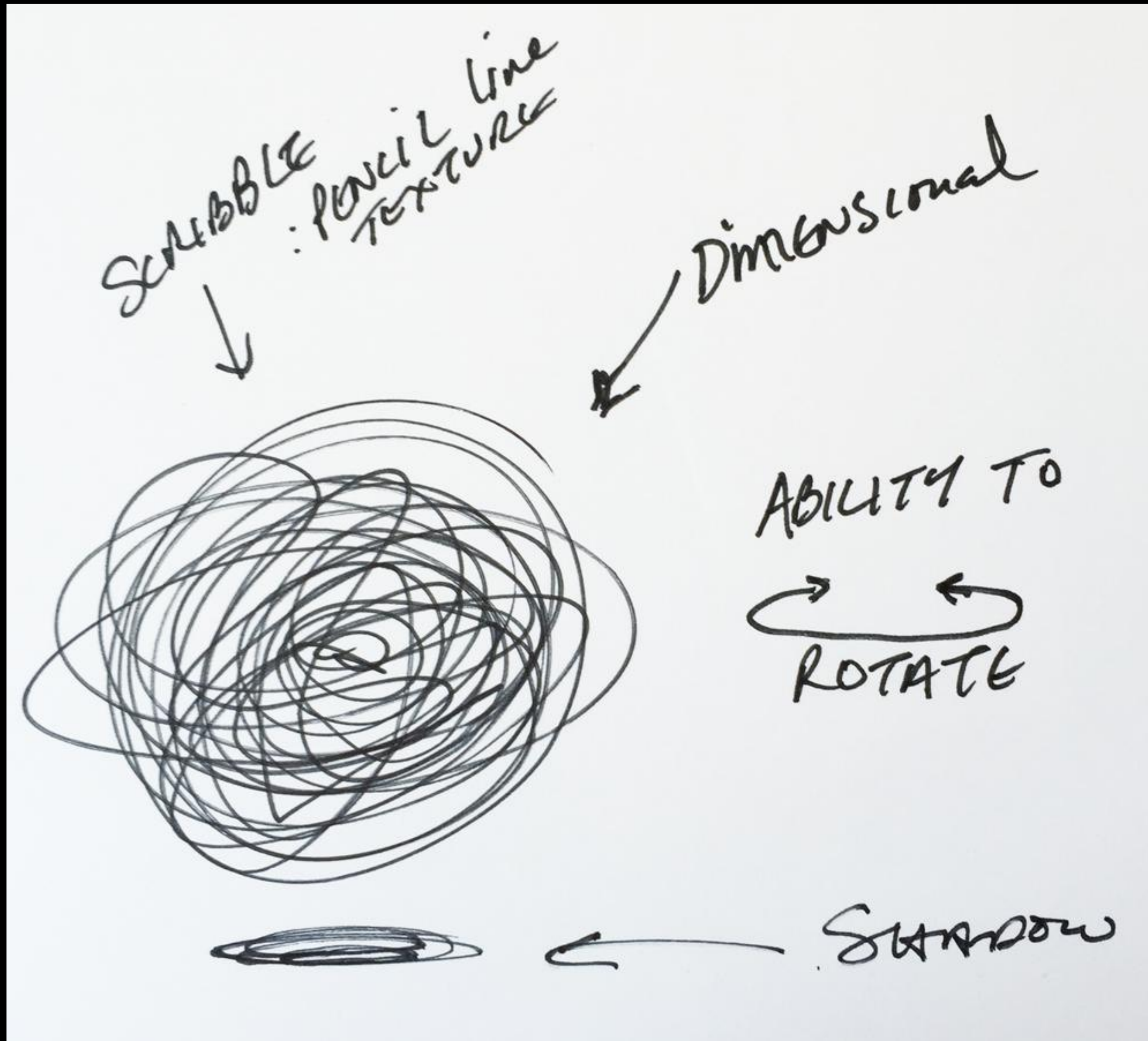

Construction

# FUNCTION / NOTES / ARROWS

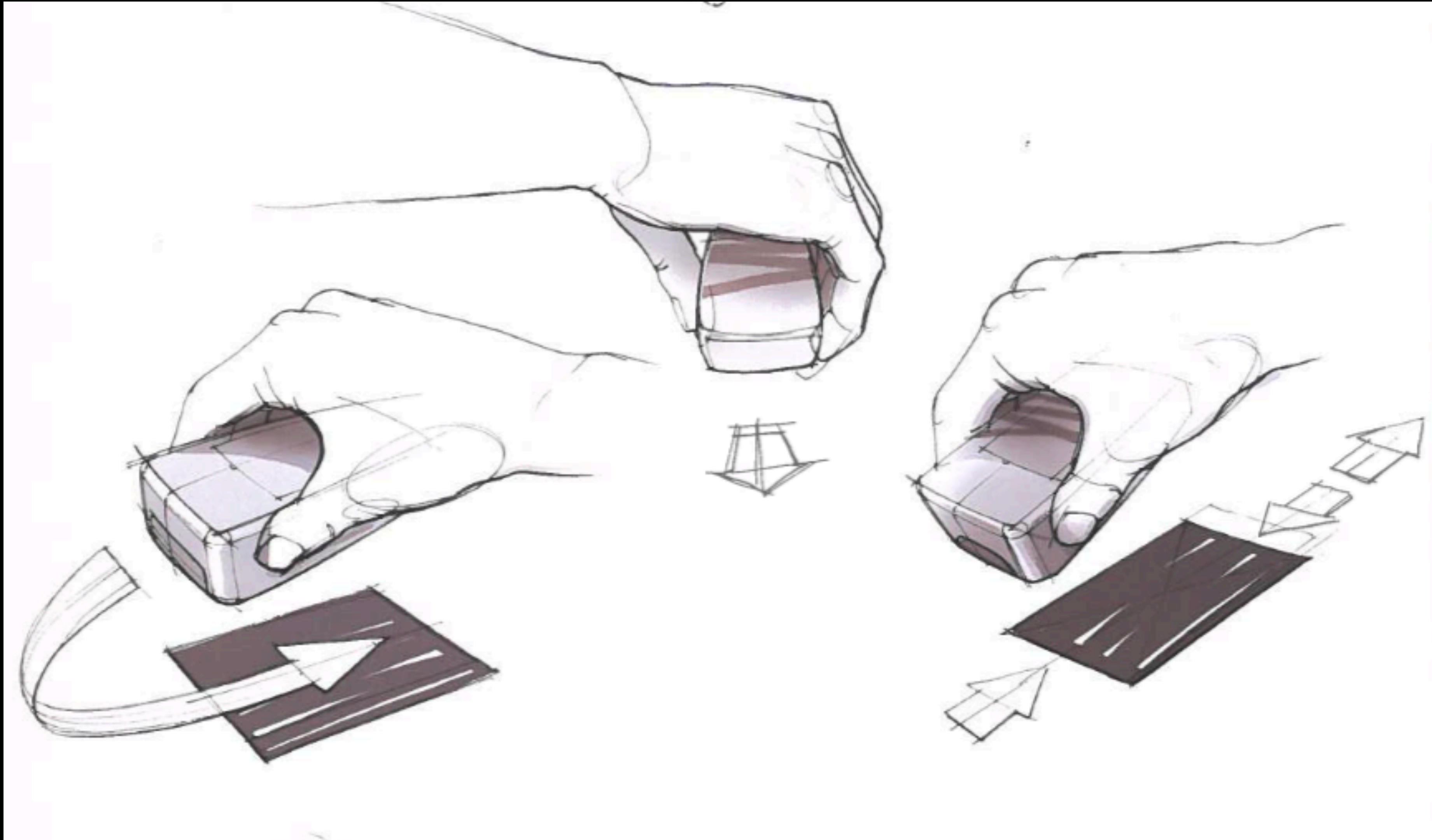

# Construction

## FUNCTION / NOTES / ARROWS

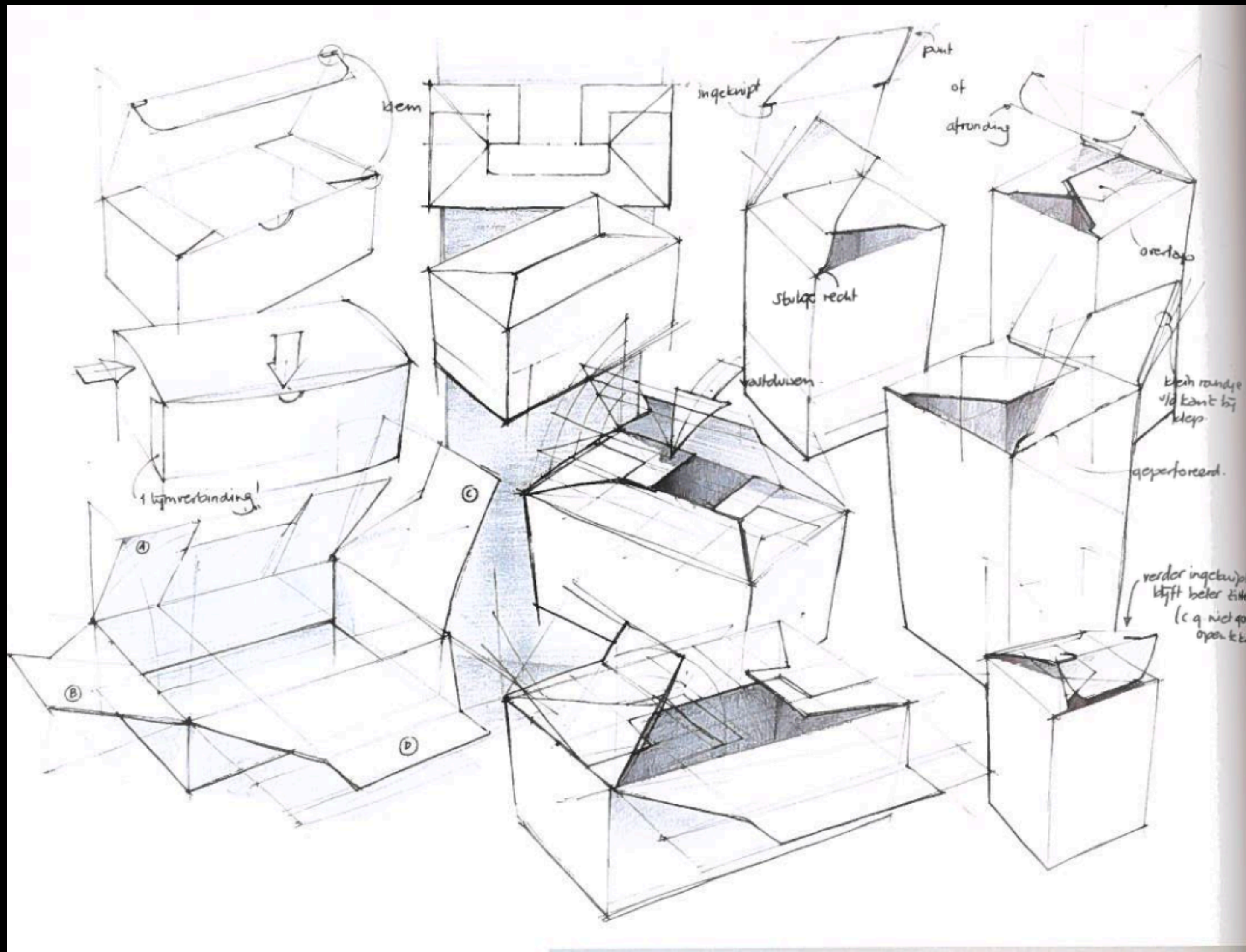

**GOAL FOR TODAY**

**ARRANGE ONE FULL PAPER  
OF AN OBJECT SKETCH!**

**I will be back at 15:30-17:00**

Exercise

**TASK TO RELAX:  
SKETCH YOUR NEIGHBOR  
BUT IN A DIFFERENT WAY...  
HOW THEY/SHE/HE CAME TO  
DESIGN?**

10 Minutes



Storytelling

## Sketch a Portrait



## Storytelling

# HOW I DISCOVERED WHAT I WANT TO DO



Storytelling

## HOW WE DO MUSIC



**Exercise 5**

# **Sections**

**3rd Perspective - Imagine a cut  
through your object**

Exercise 6

# **3rd Perspective - Pay attention to the direction shadows**

Storytelling

DOODLE TO SCRIBBLE



doodle + scribble



**BREAK!**



**Exercise 8**

# **FUNCTIONS & ARROWS**

## **Integrate some functions**

**5 Minutes**

FOR TOMORROW

**BRING 1 STRONG PENCIL!**

# Thank you!

Contact

**Rasa Weber** | [rasa.weber@zhdk.ch](mailto:rasa.weber@zhdk.ch)

**Z**

hdk

Zürcher Hochschule der Künste  
Bachelor of Arts in Design