

Z

hdk

Zürcher Hochschule der Künste
Bachelor of Arts in Design

Designing Object Experience

Sketching III

Object Experience | 24th of September 2021

lecturer
Rasa Weber

Overview

Today's Schedule

10:00
⋮

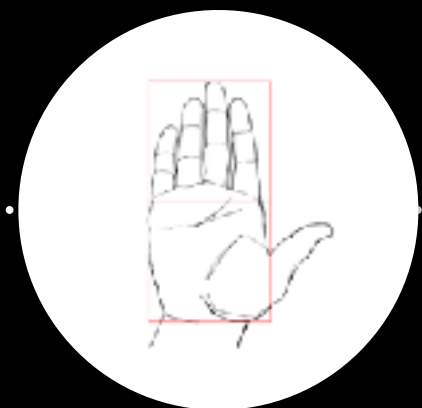

**Hands
(limbs)**

10:45
⋮



**Hands &
Object**

11:30
⋮

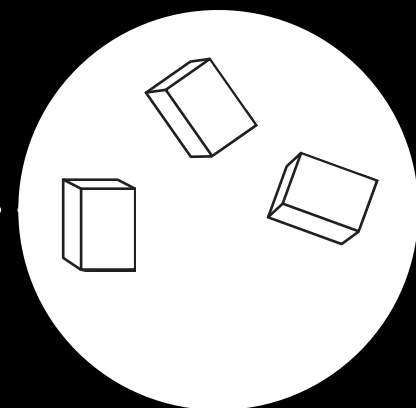

Sequences

12:15
⋮

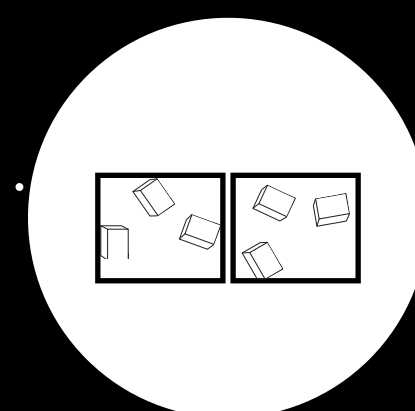

Story Board

Lunch Break

13:00
⋮

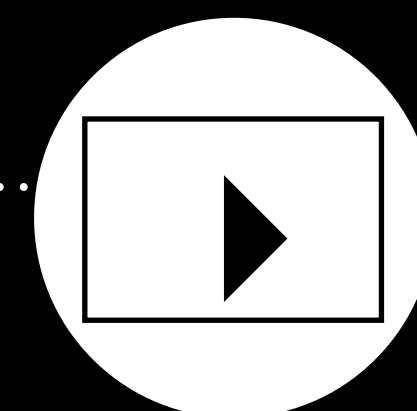

Stop Motion

15:00
⋮

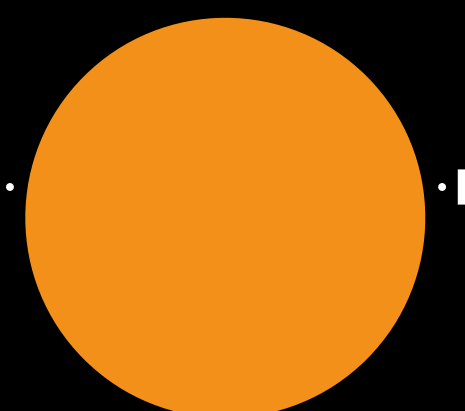

**Present
your
results!**

Exercise 1

QUICK START

8 MINUTE COLOR SKETCH

Exercise 2

**TODAY'S GOAL:
SKETCH A STORY OF
USING AN OBJECT
(INCLUDE HANDS / FEET...)!**

Animating

STORY BOARD

Narrative

Sketching Sequences



Narrative

Filmmaking Chosing Ankles



Narrative

Telling Stories of Use

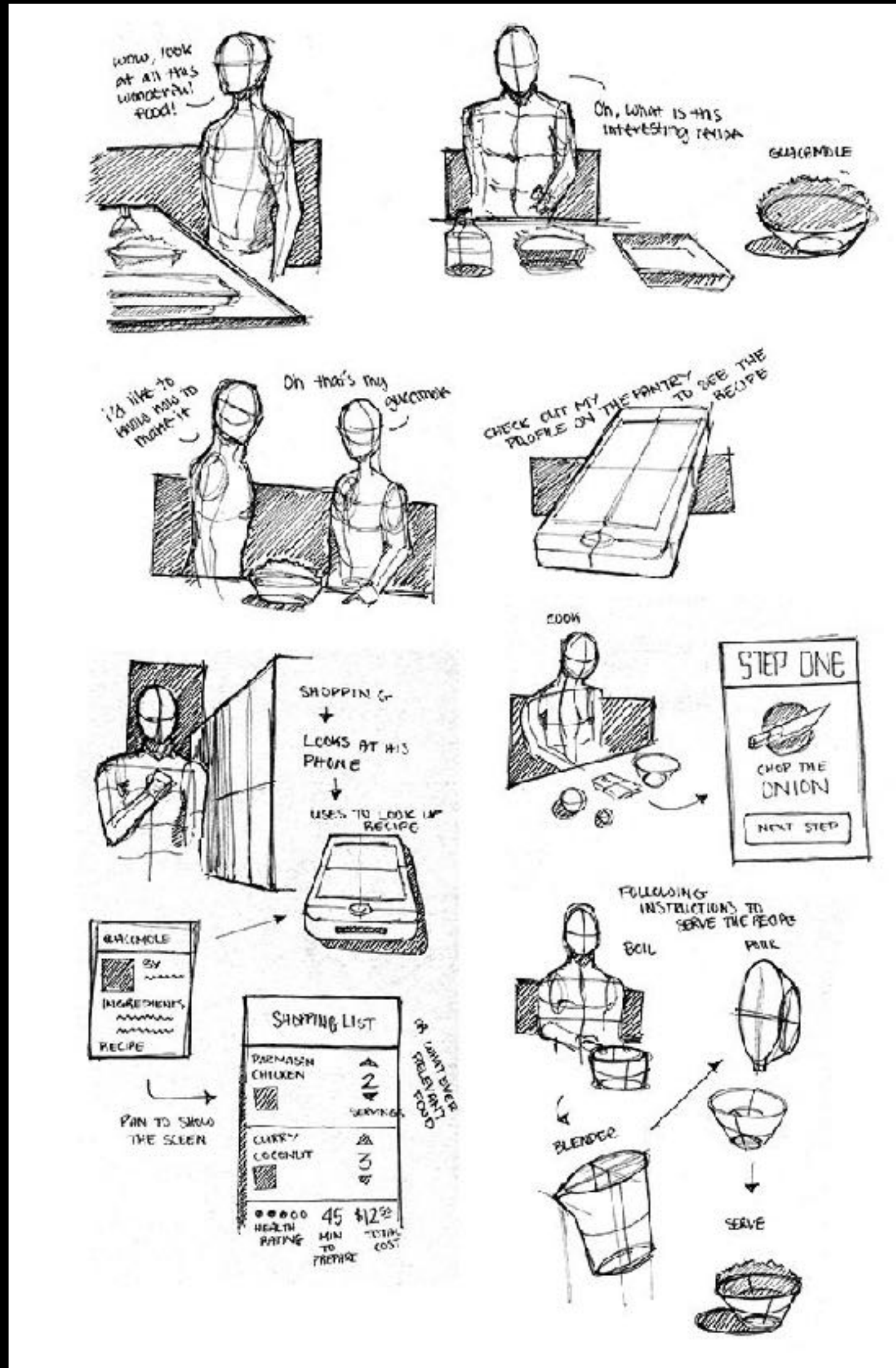

SKETCHING

SEQUENCES

Narrative

Telling Storyies of Use

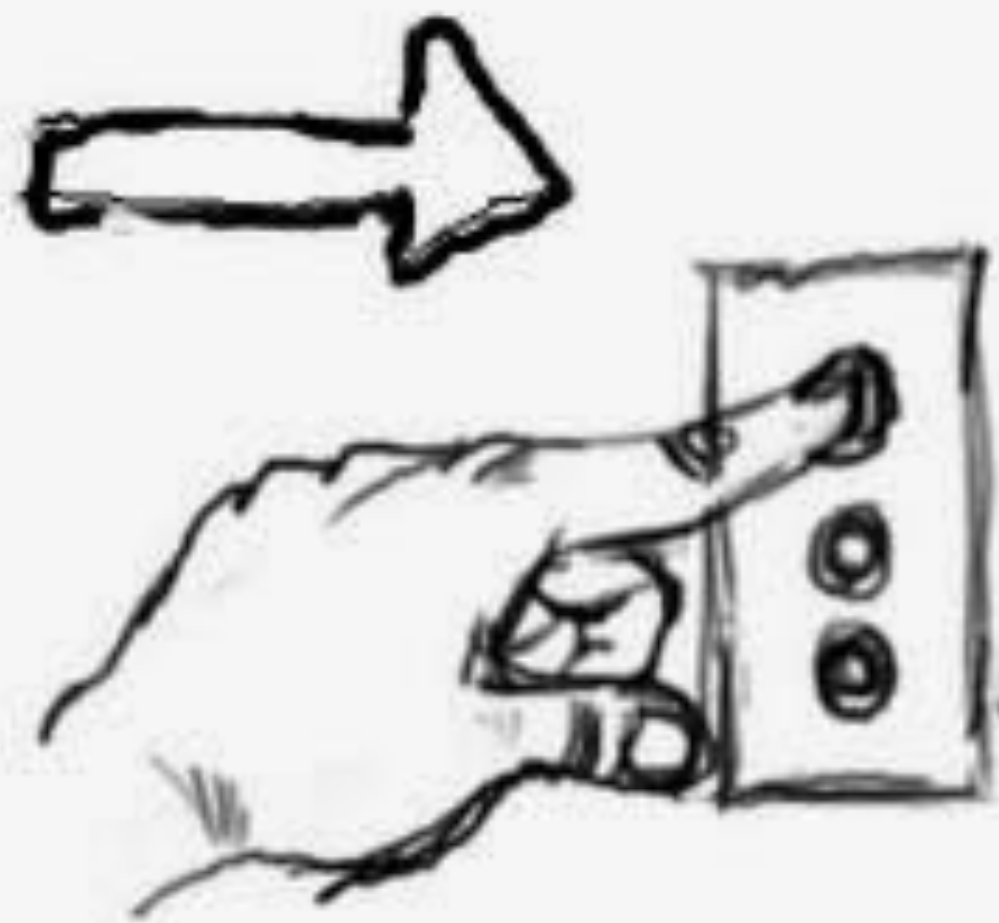

Button - Push



Switch - Flip



Knob - Rotate

Construction
Steps of Use

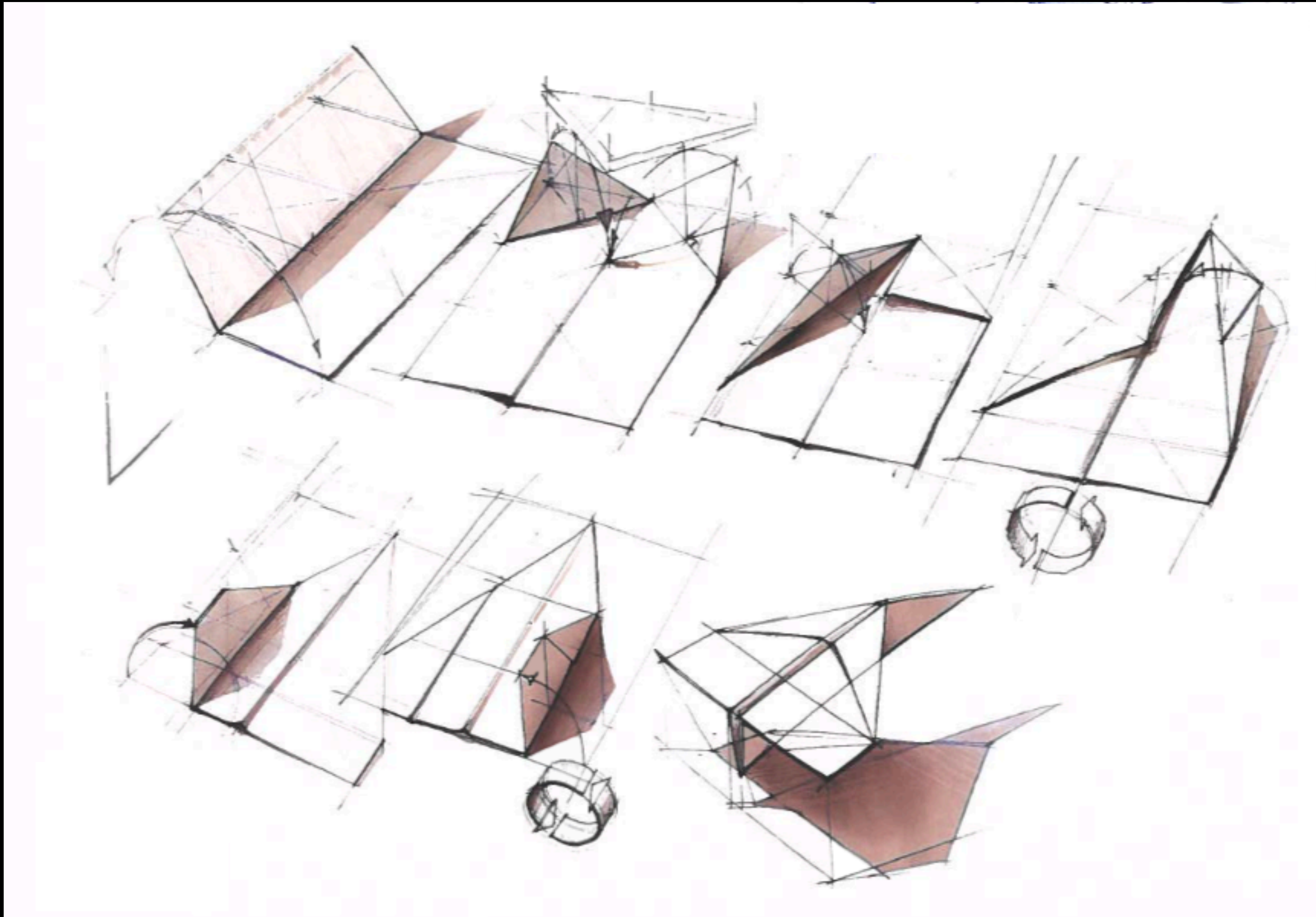

Construction

Integrating the hand

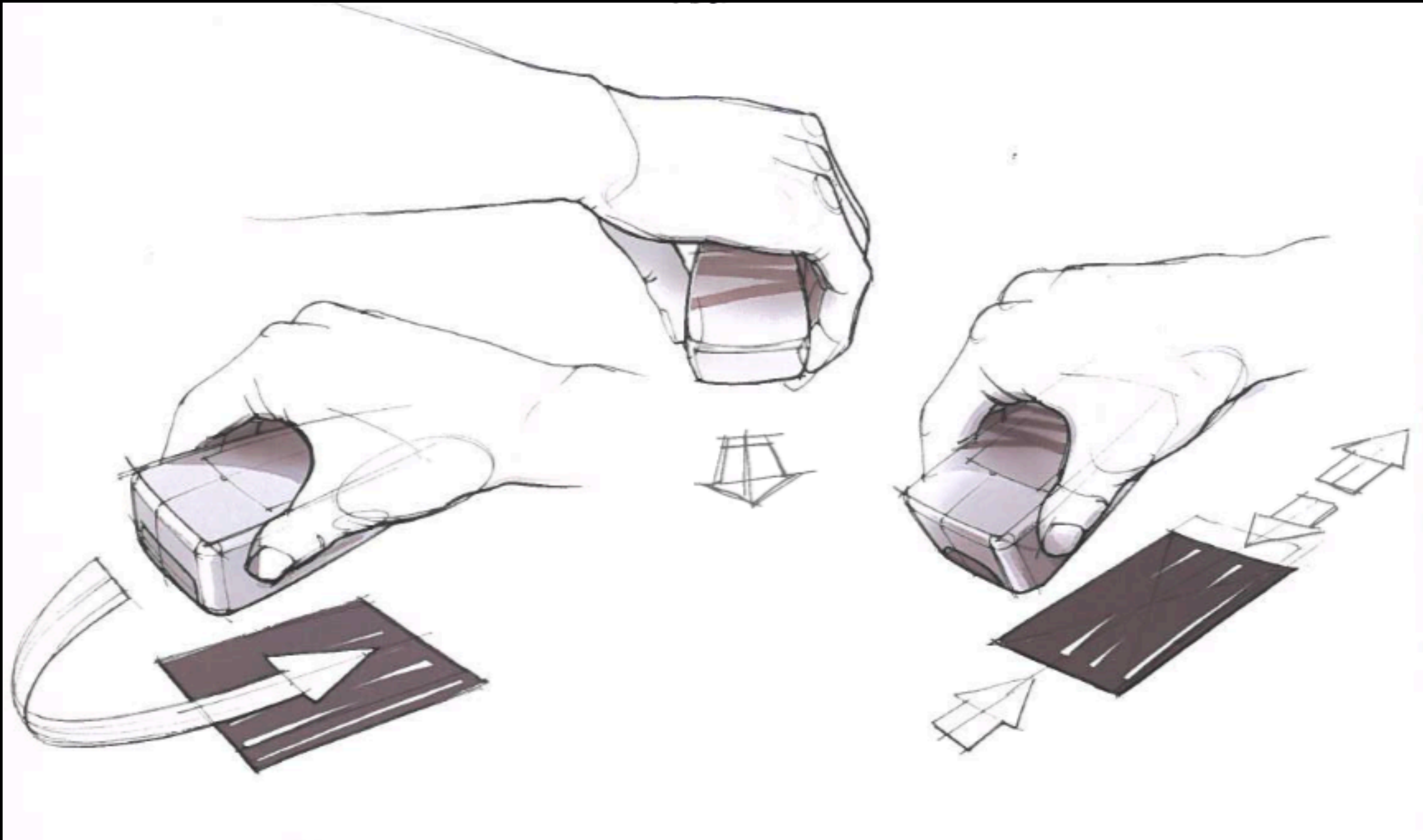

Construction

Chosing the right moment

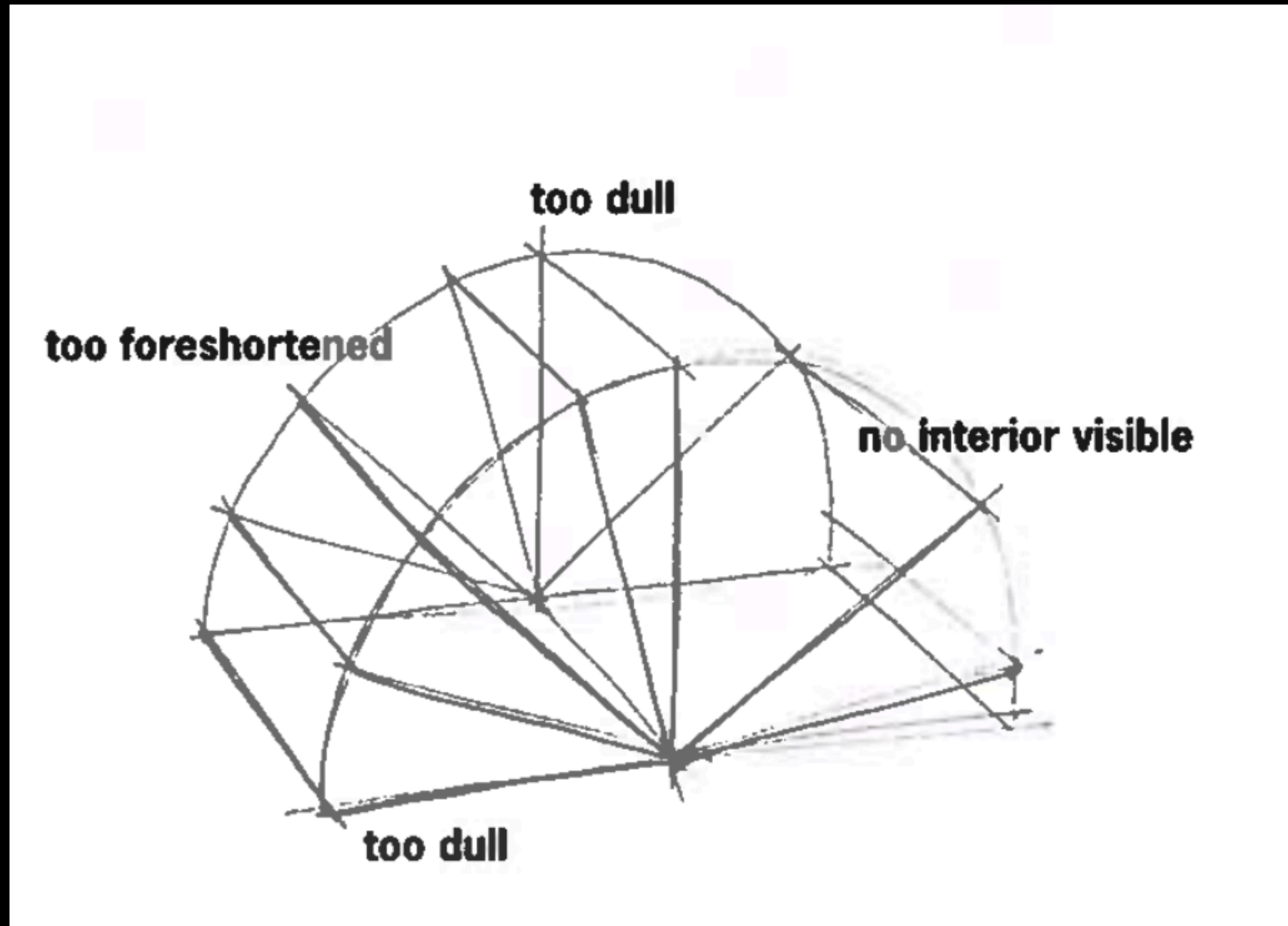

Construction

Adding Notes

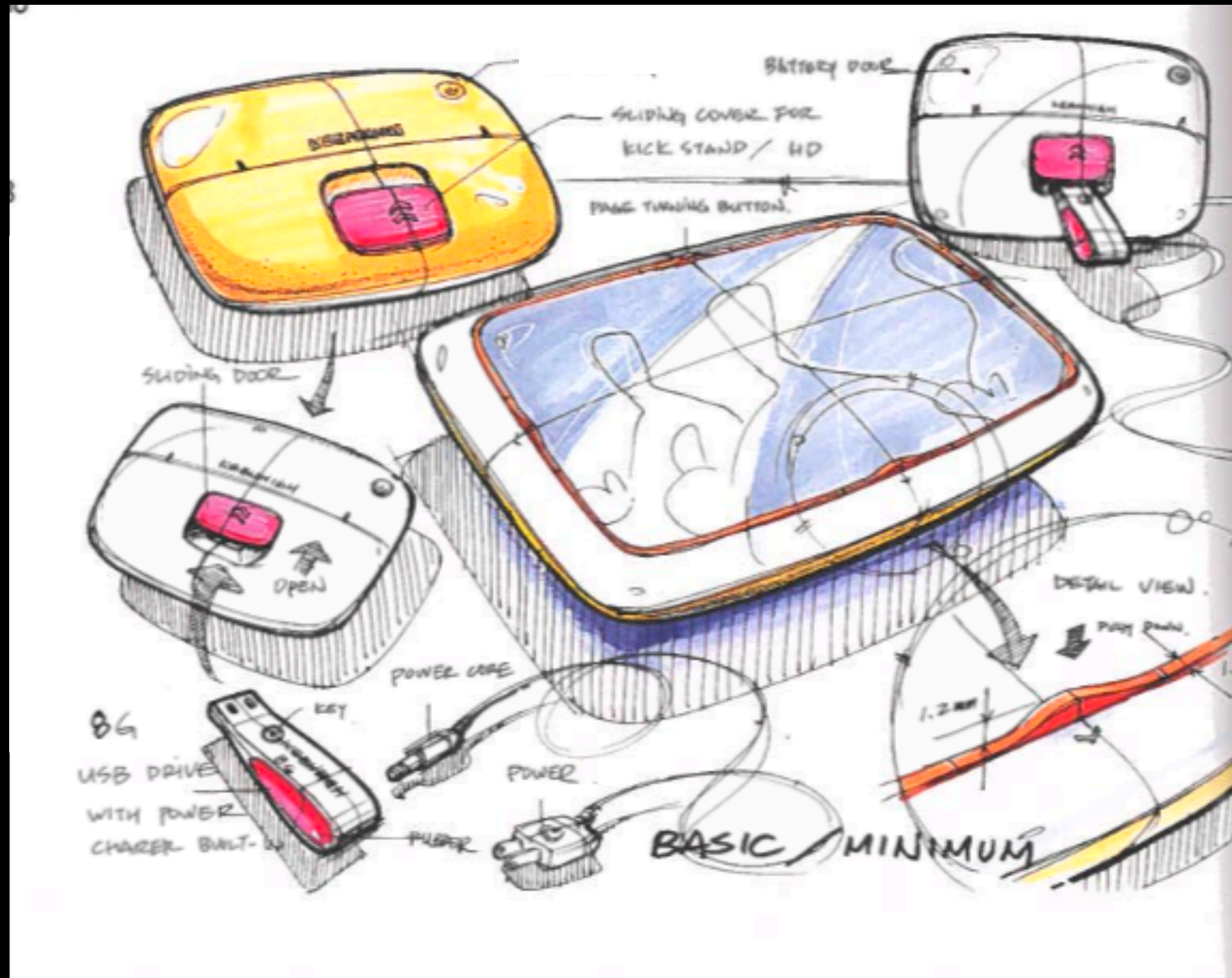

SKETCHING

Hands

Construction Using Objects

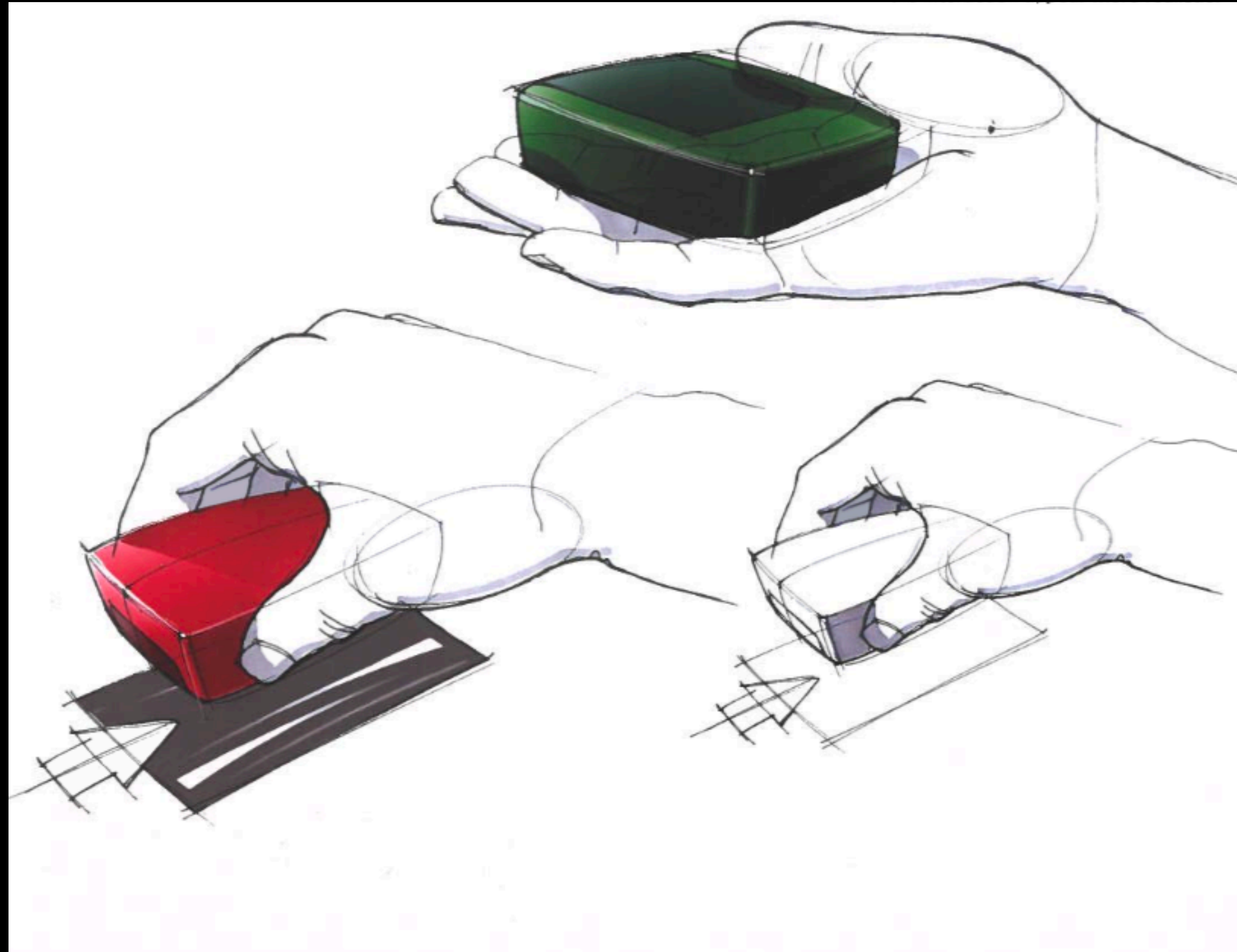

Construction Hand Anatomy



Abb. 134:

Skelett einer rechten Hand.

links: Skelett handrückenwärts

rechts: Innenseite der Hand

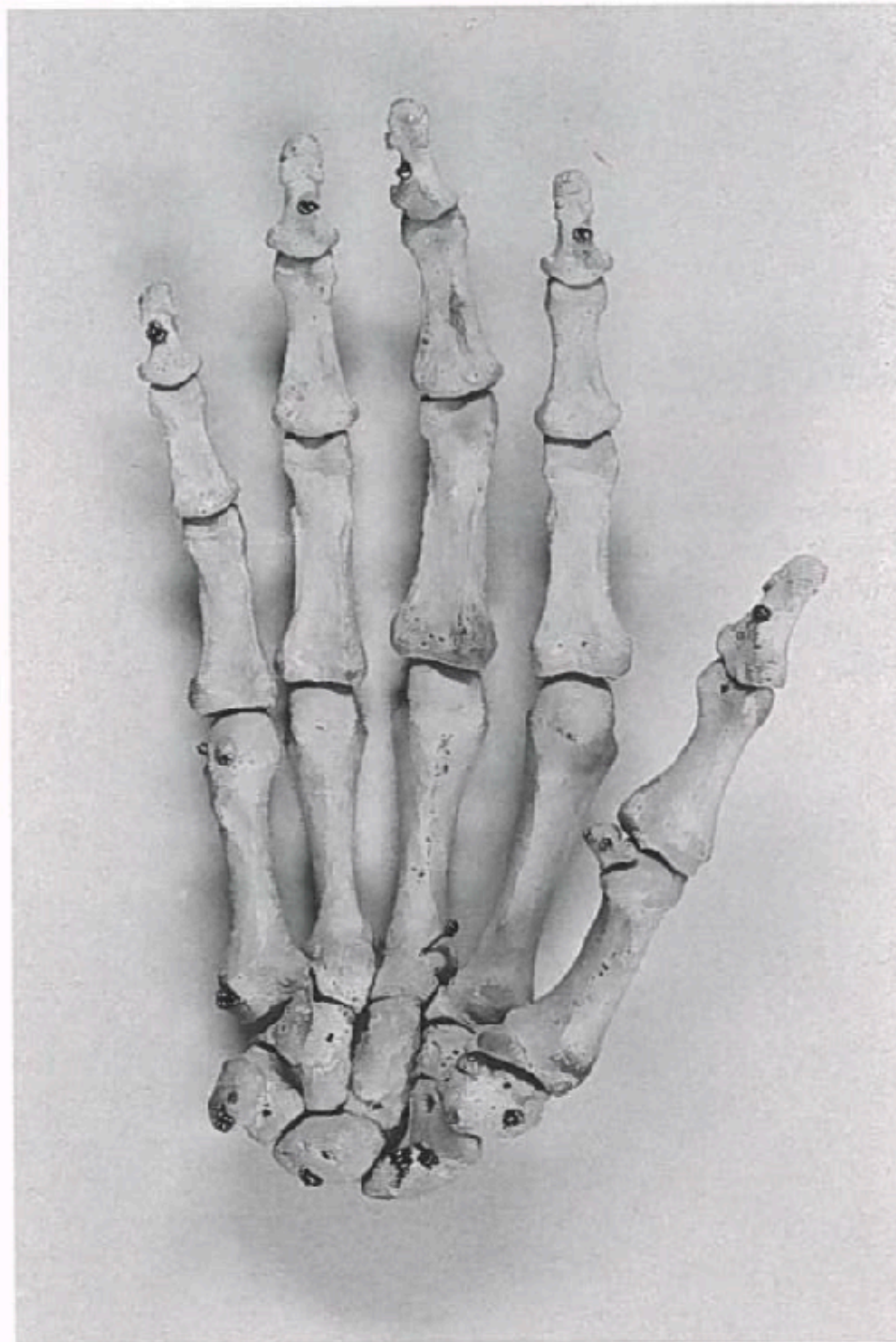
1 - Schiff- oder Kahnbein, 2 - Mondbein, 3 - Dreiecksbein,
 4 - großes Vielecksbein, 5 - kleines Vielecksbein, 6 - Kopfbein,
 7 - Hakenbein, 8 - Erbsenbein, 9 - Grundglied eines Fingers,
 10 - Mittelglied eines Fingers, 11 - Nagelglied eines Fingers

I - Handwurzelknochen

II - Mittelhandknochen

III - Fingerknochen

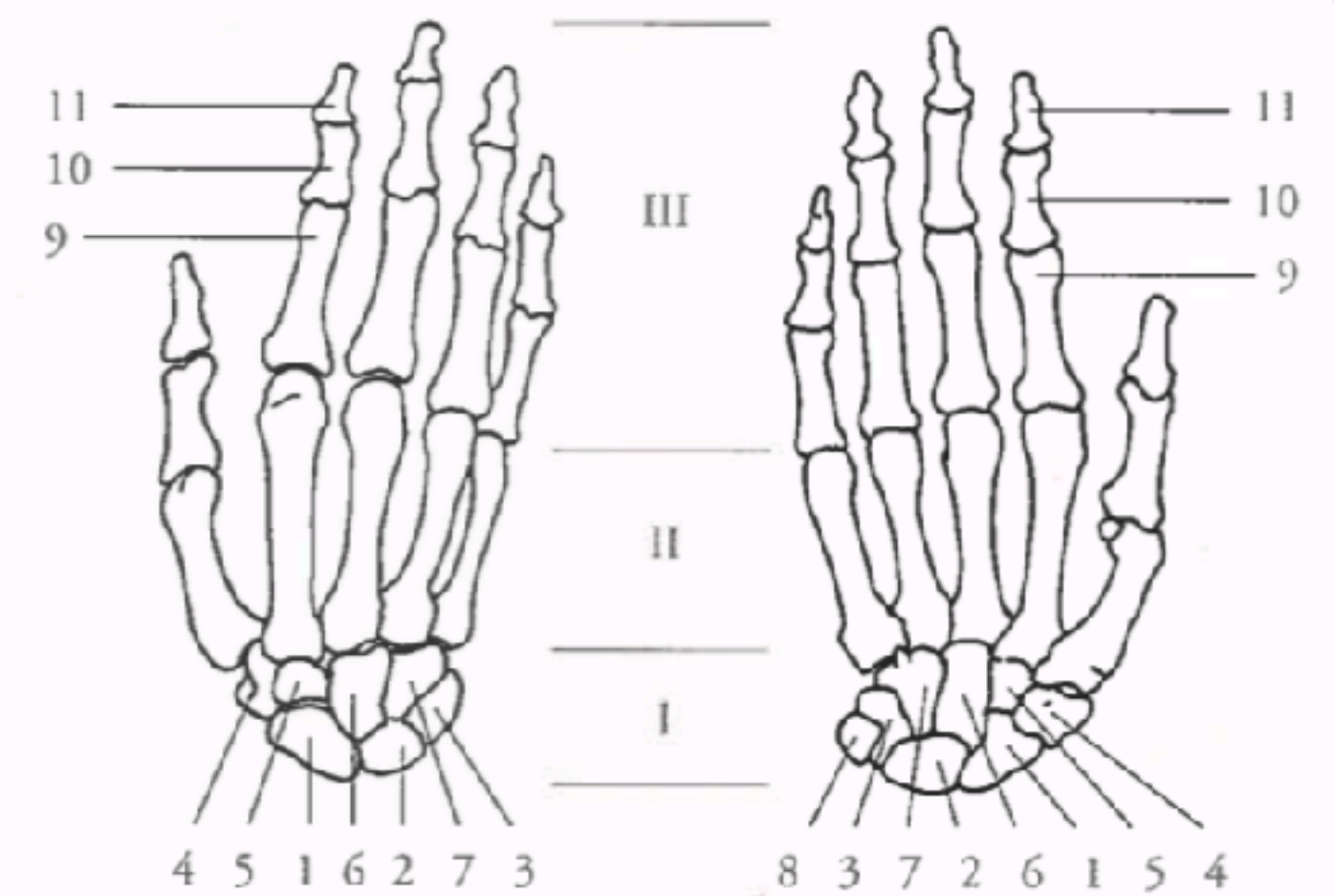

Construction
Hand Anatomy

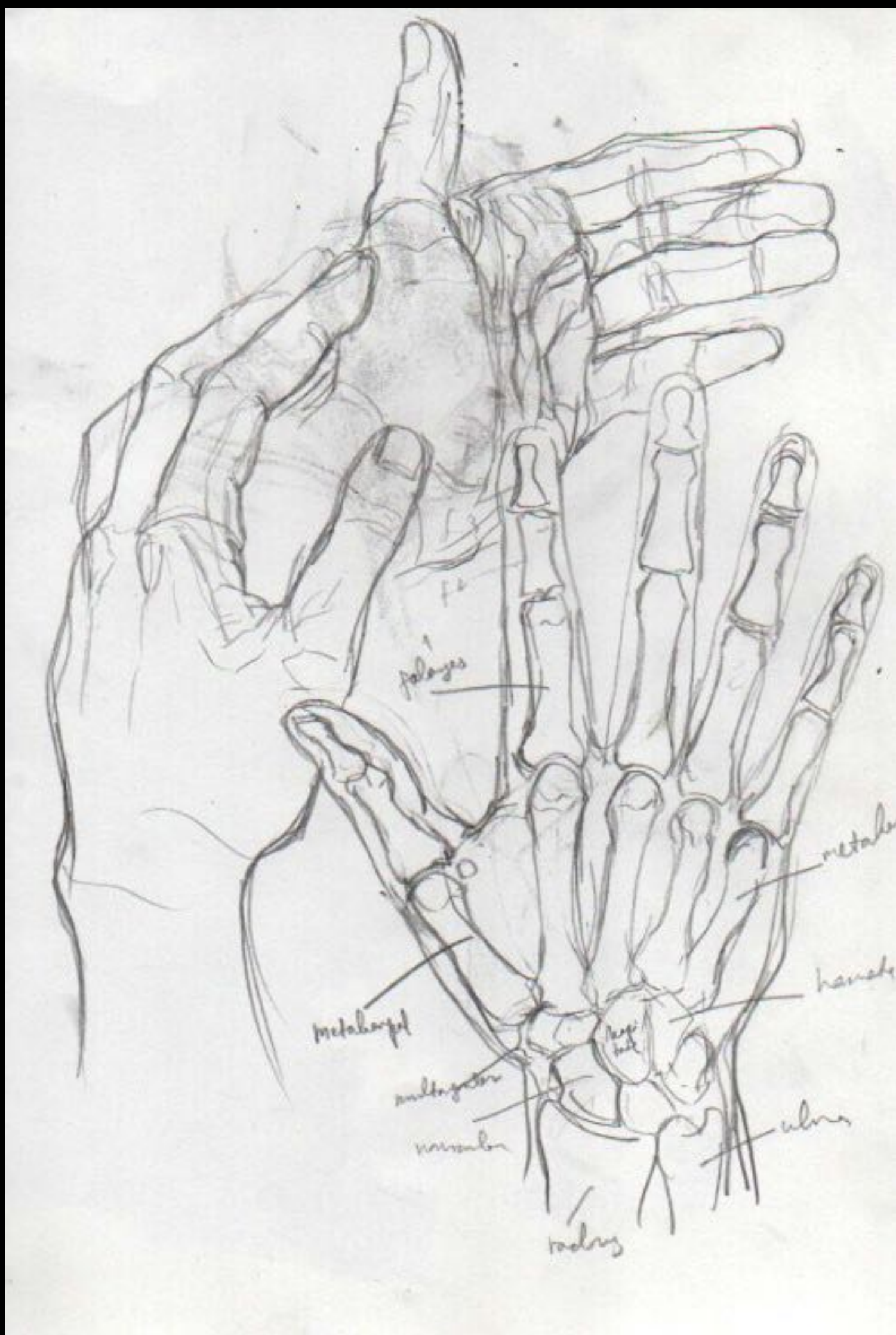

Construction Hand Proportions

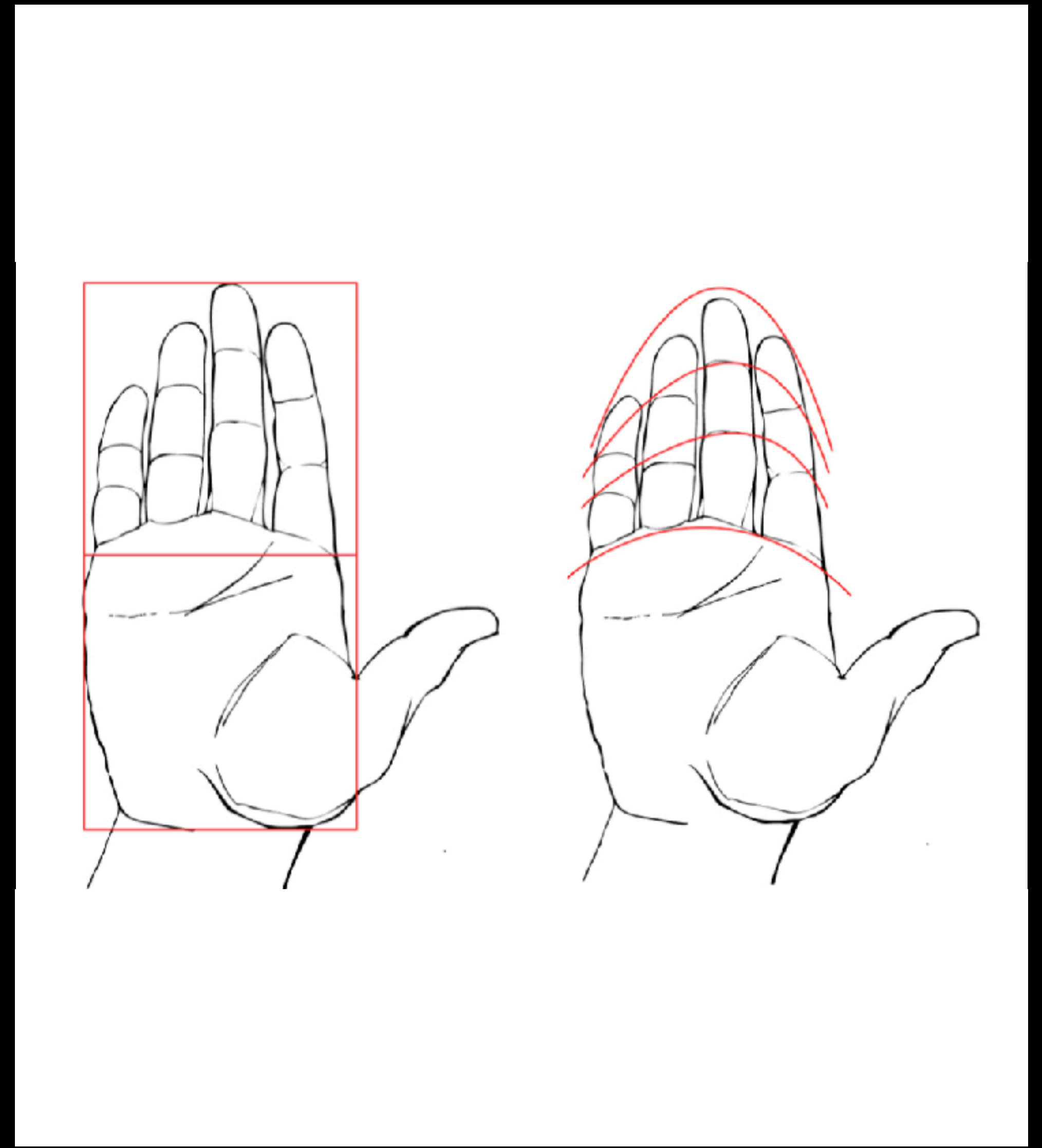
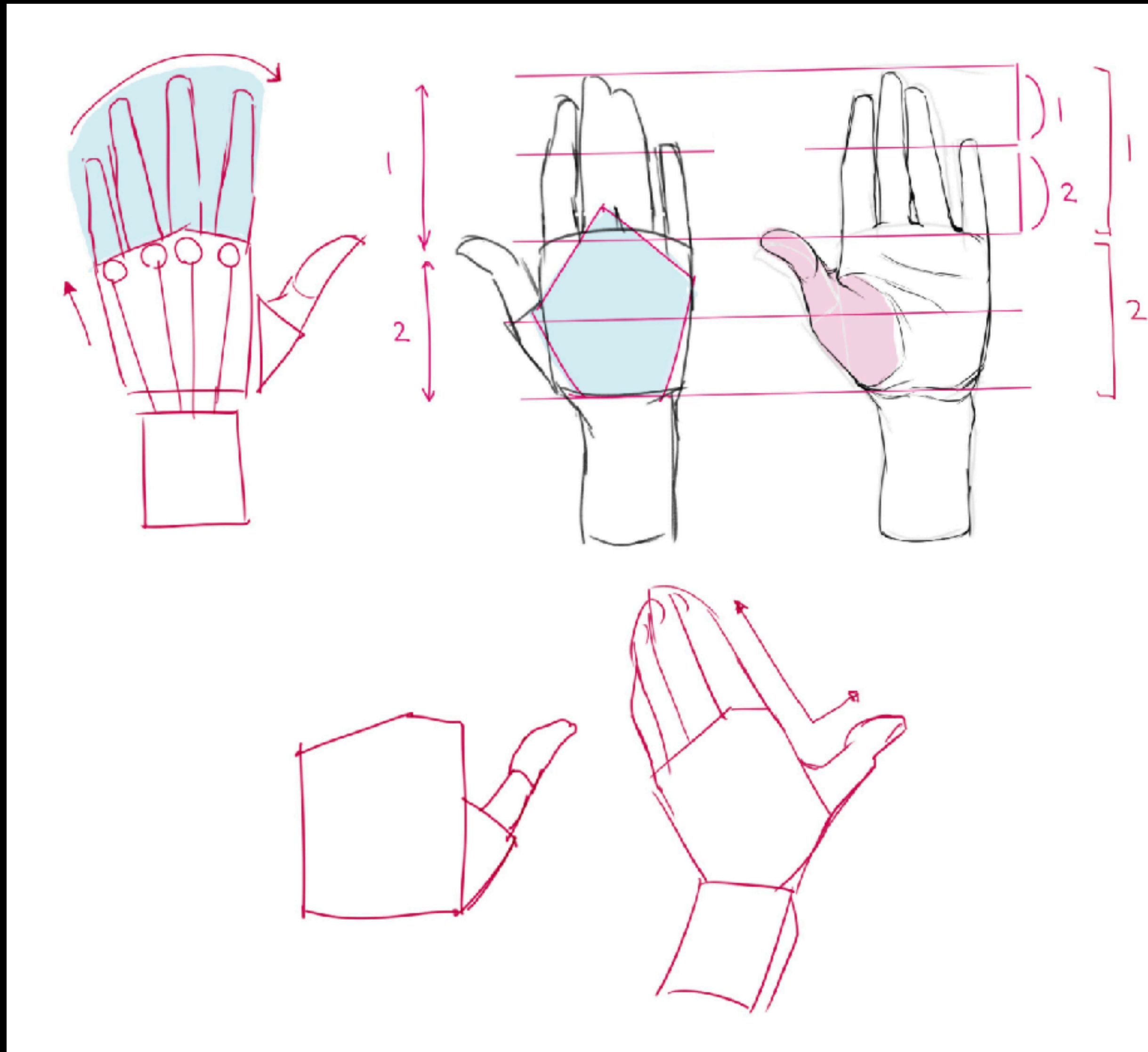

Construction Hand Proportions

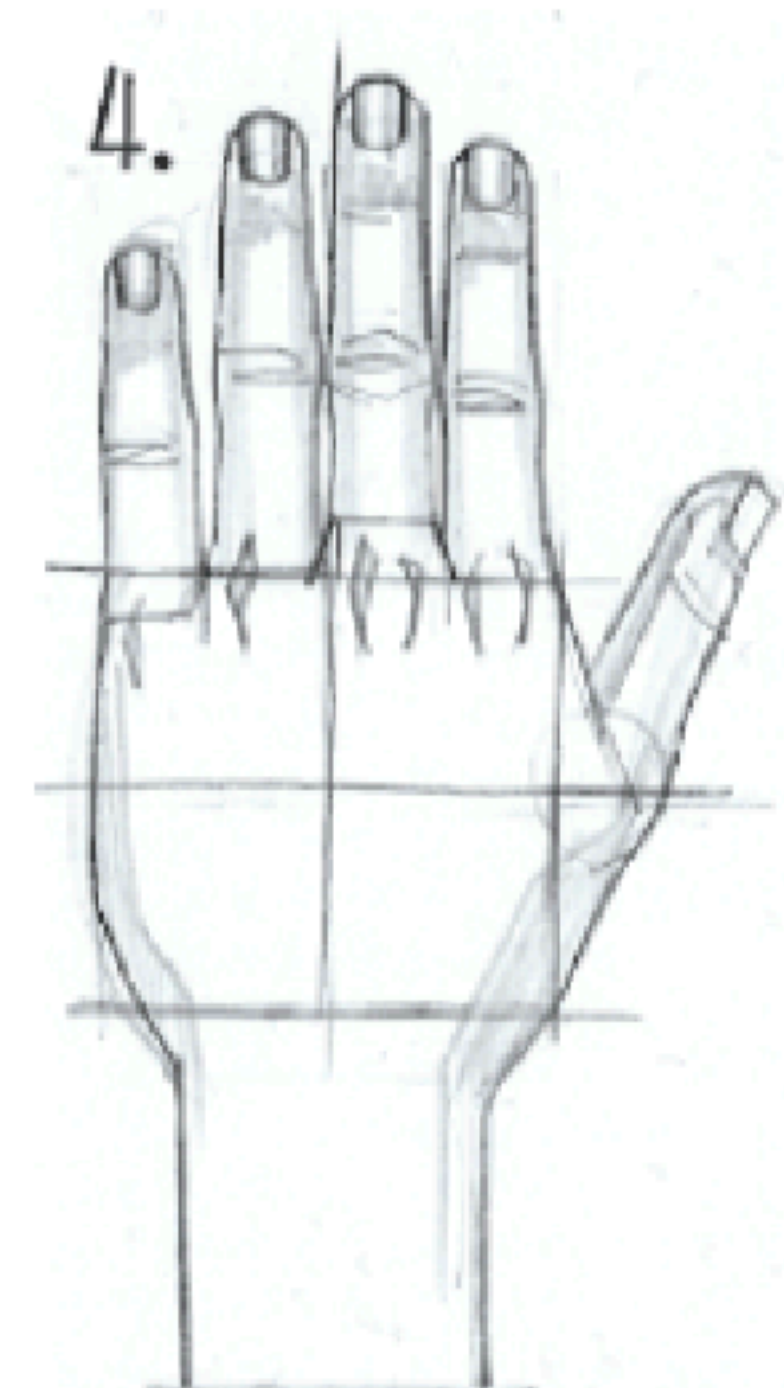
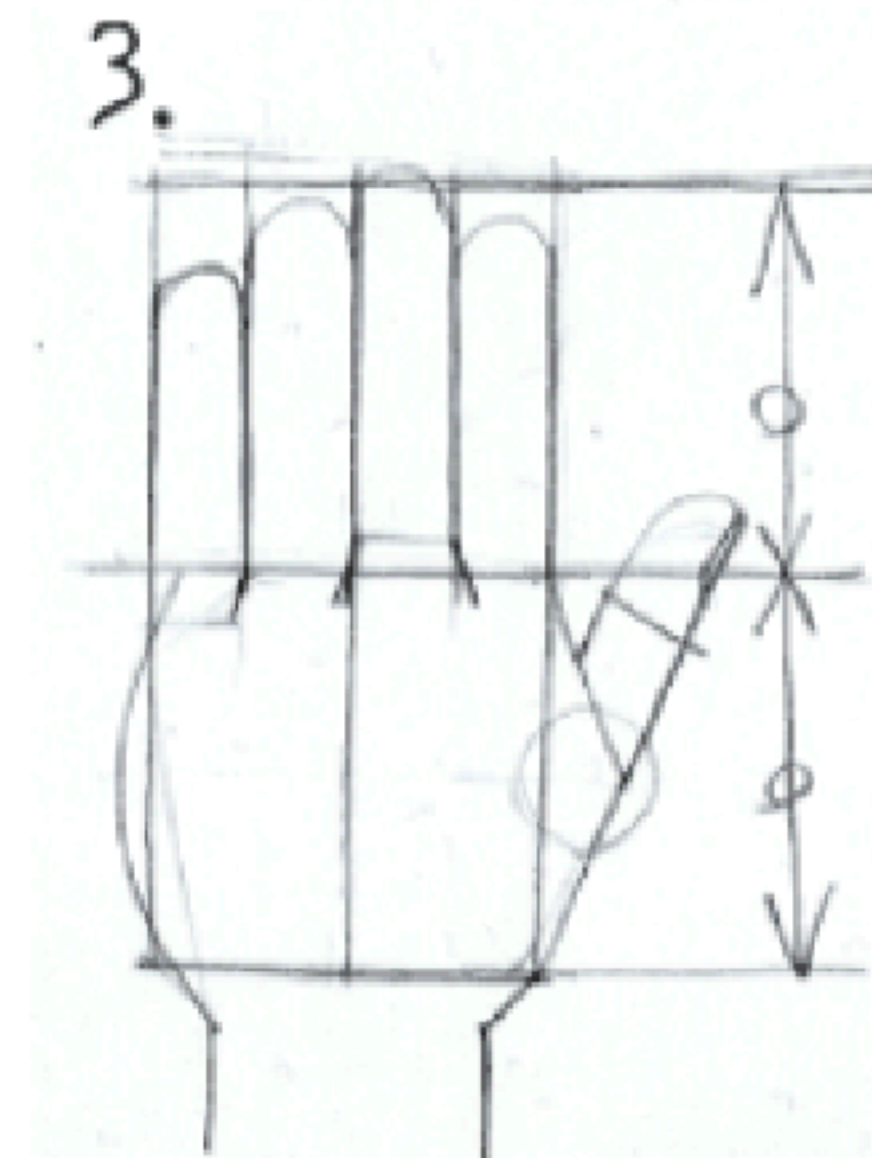
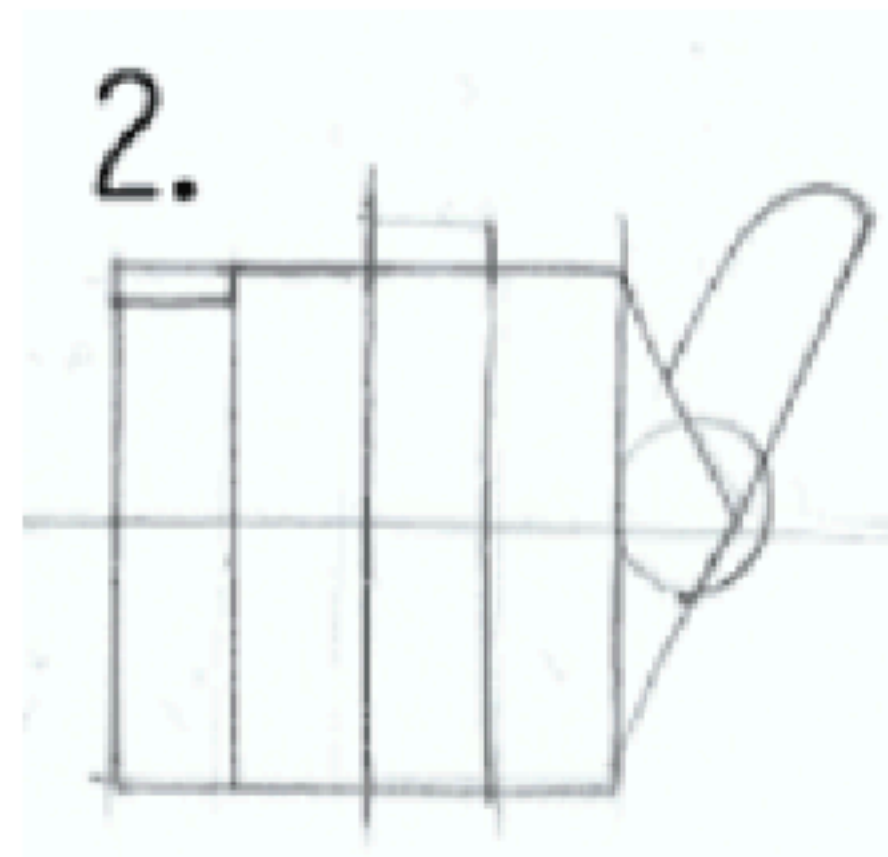
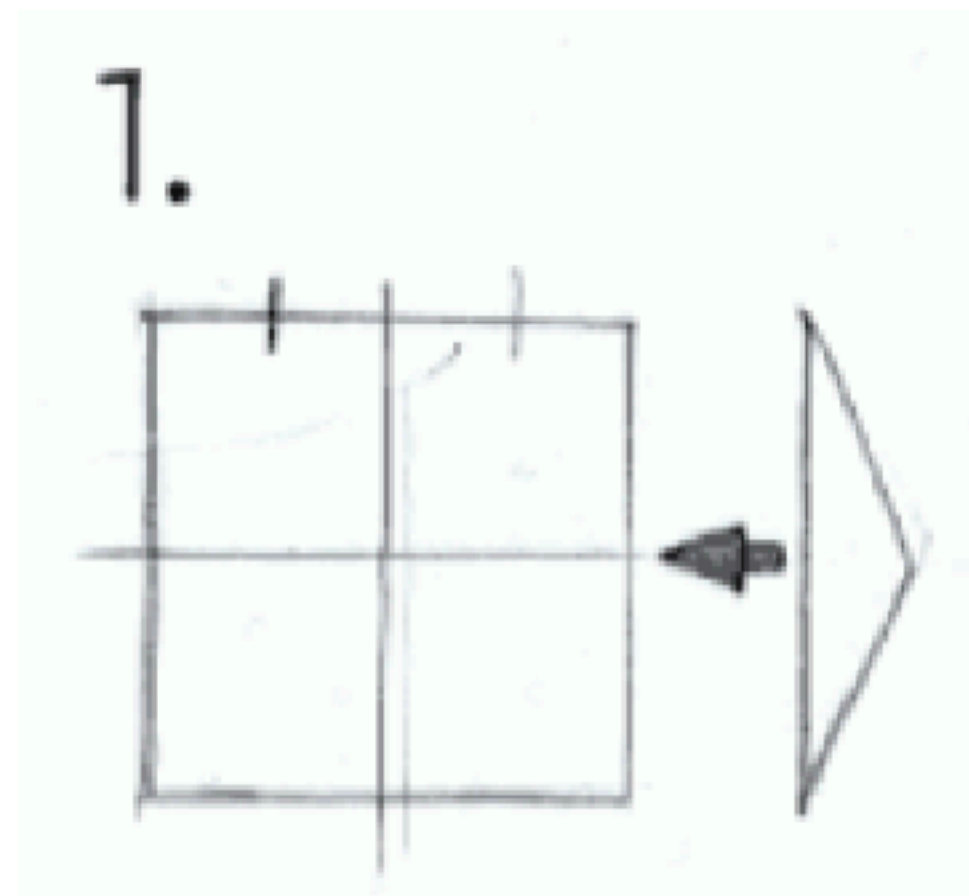

Construction

Actual Proportions



**3. SKETCH
WHAT YOU
SEE!**

Christo Morto,
Andrea Mantegna,
1475-1478.

Construction Hand Studies



Leonardo Da Vinci
Study of Hands,
1480.



Leonardo Da Vinci
the bones muscles and
tendons of the hand
1510-1511.

Construction
Hand Study



Albrecht Dürer,
Betende Hände,
1508.

Construction

Feet Studies & Anatomy



Abb. 93:
Verklammerung des Längsgewölbes des Fußes
(verändert nach Voss und Herrlinger 1966).

- 1 - Plantaraponeurose
- 2 - langes Fußsohlenband
- 3 - Achillessehne
- Z - Zugspannungslinie
- D - Druckspannungslinie



Construction
Using an Object

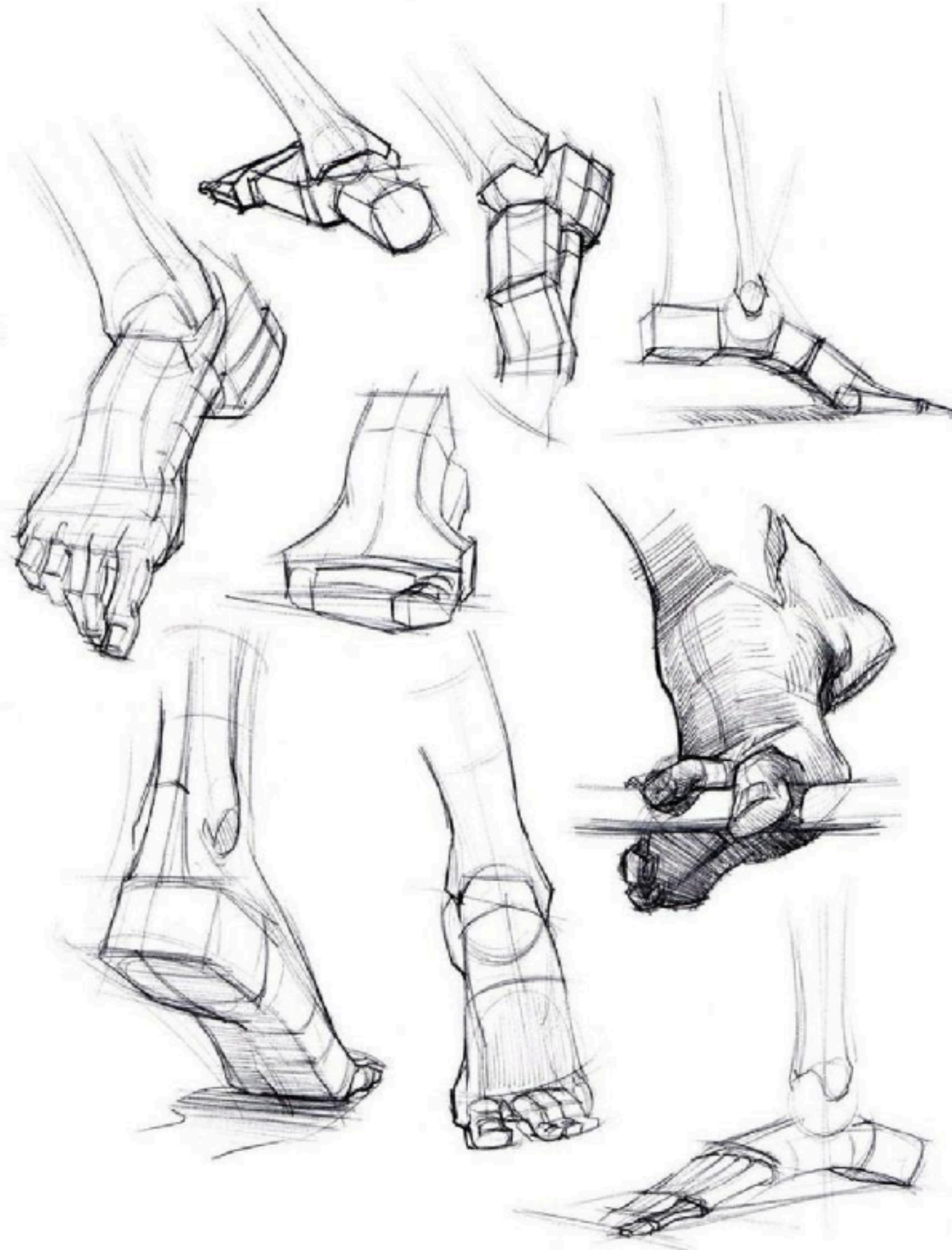
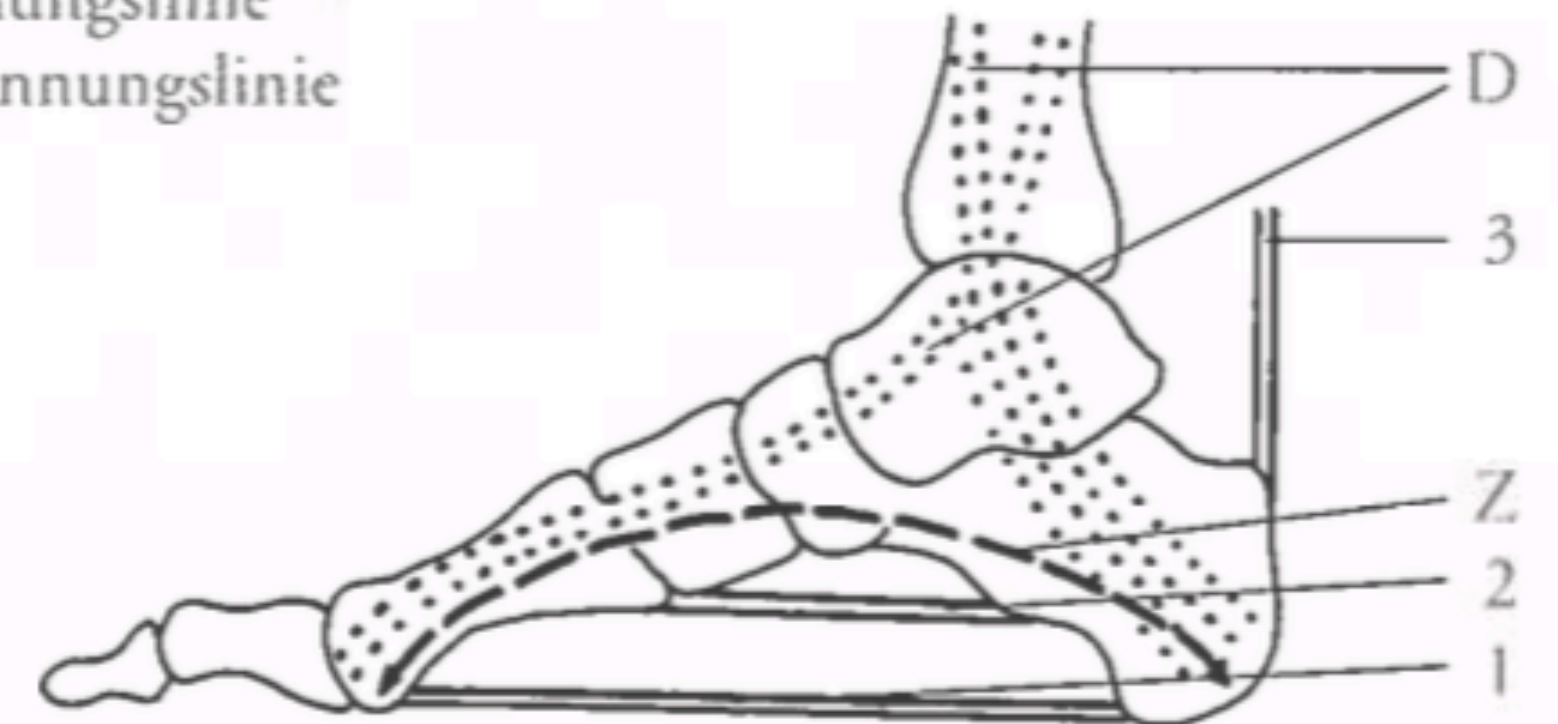
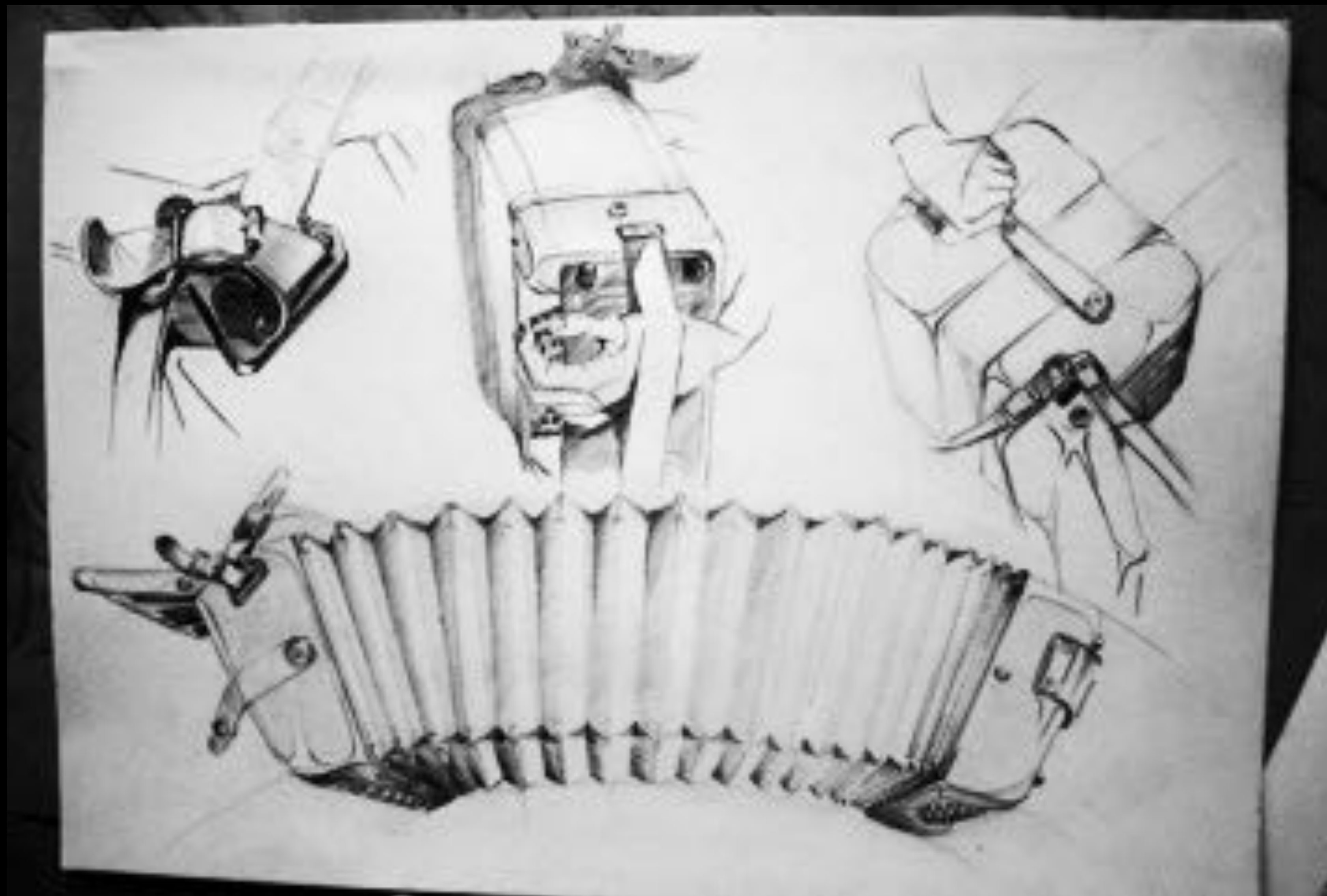

Construction Using an Object



Exercise 2

Hands

Exercise 2.2

Hands & Object

Animating

STORY BOARD

Narrative

Stop Motion Interaction Design

Z

hdk

Zürcher Hochschule der Künste
Zürcher Fachhochschule

interaction
design

Bachelor of Arts in Design

Narrative

Stop Motion „Hier und Weg“ by Michael Marks



Exercise 3

Stop Motion

„MINIMIZE TO THE MAXIMUM!“

Presentation

Sketching results of the week

15:00-17:00

HOMework

- FINISH YOUR SKETCHES**
- EDIT THE MOVIE ABOUT YOURSELF**
- FINALIZE THE STOP-MOTION SEQUENCE**

Thank you!

Contact

Rasa Weber | rasa.weber@zhdk.ch

Z

hdk

Zürcher Hochschule der Künste
Bachelor of Arts in Design