

Z

hdk

Zürcher Hochschule der Künste
Bachelor of Arts in Design

Designing Object Experience

Sketching II

Object Experience | 23rd of September 2021

lecturer
Rasa Weber

Overview

Today's Schedule

10:00

⋮

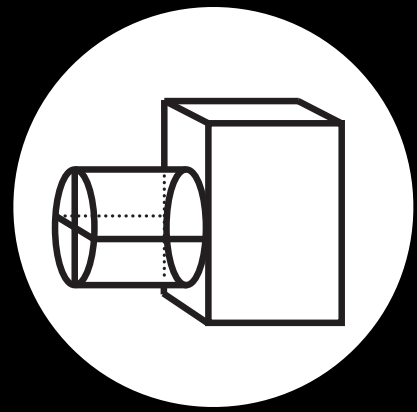

**Geometric
Construction**

10:45

⋮

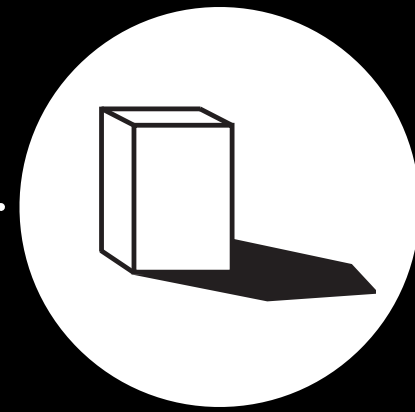

Shadowing

11:30

⋮

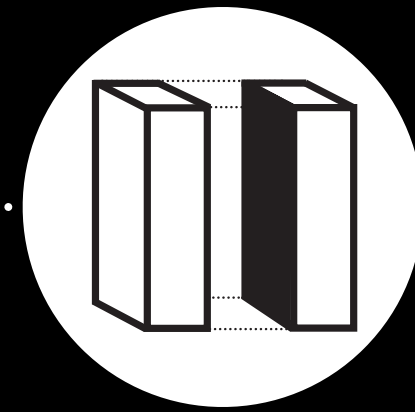

Sections

12:15

⋮

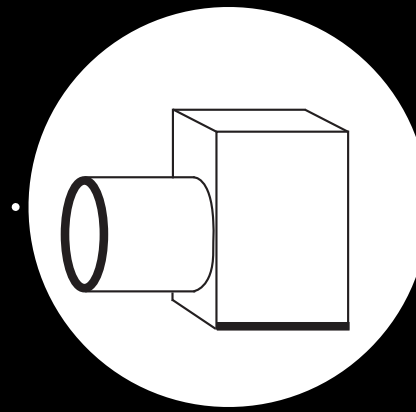

**Strokes
Focal Point**

13:15

⋮

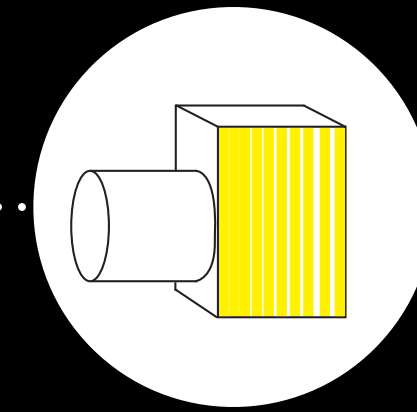

Coloring

SKETCHING

CONSTRUCTIONS

Construction
Basic Shapes

Cube

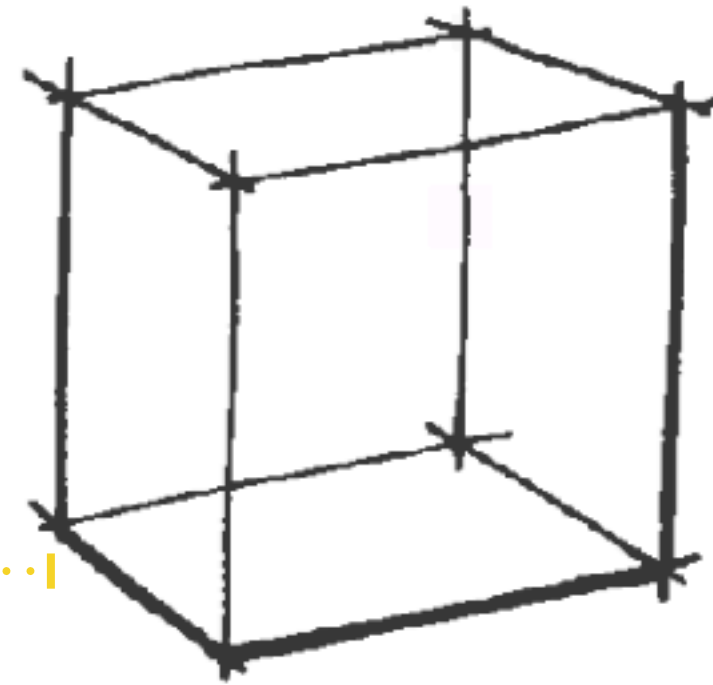

Axis

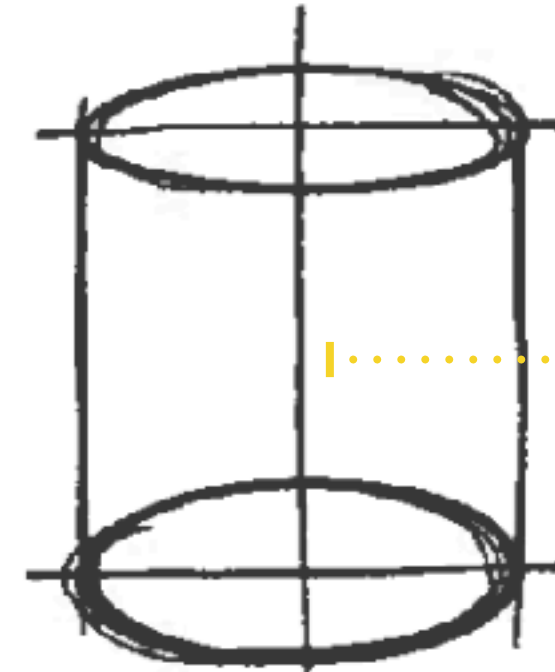

Cylinder

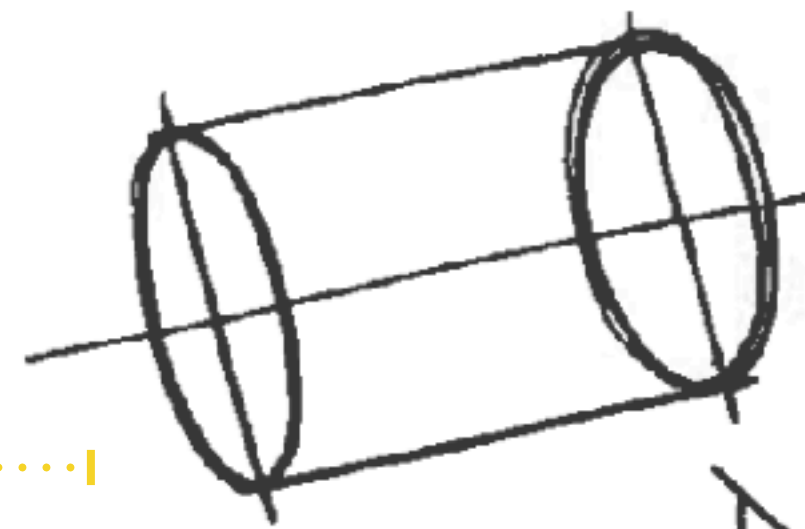

Sphere

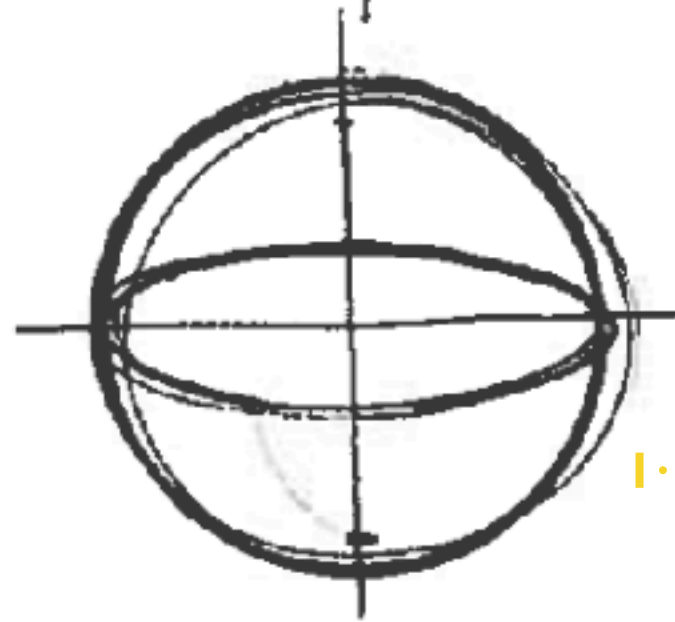

Surface

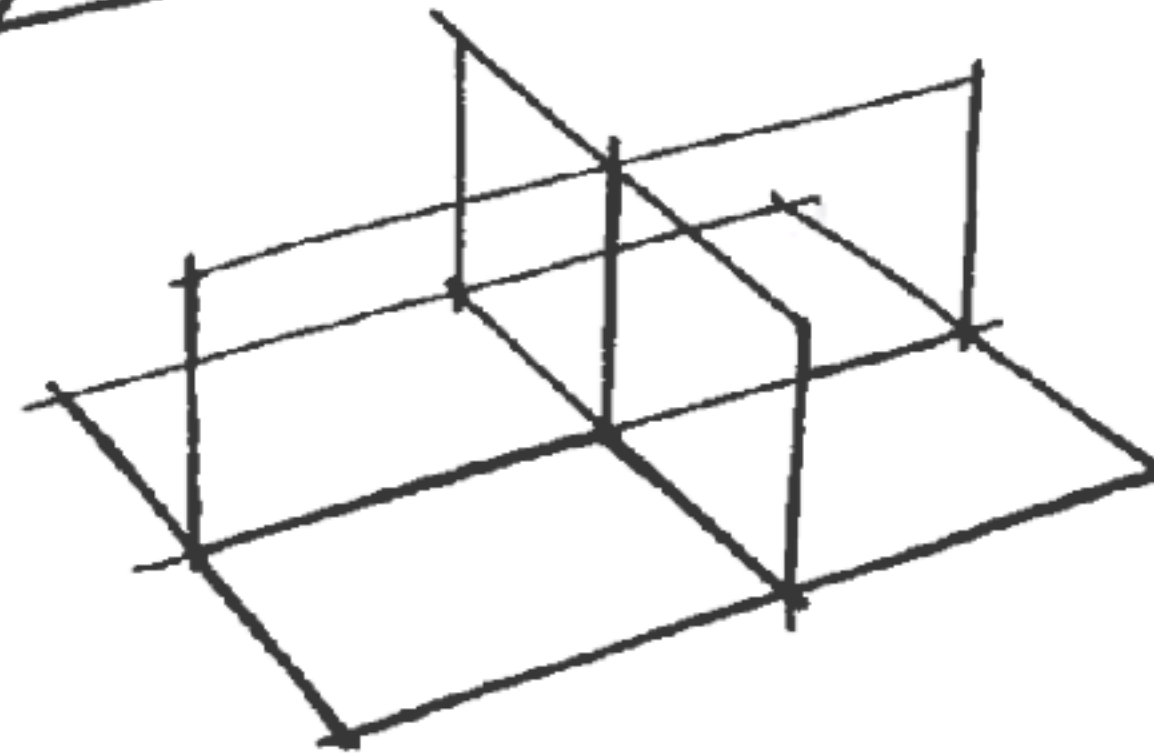

Construction
Basic Shapes

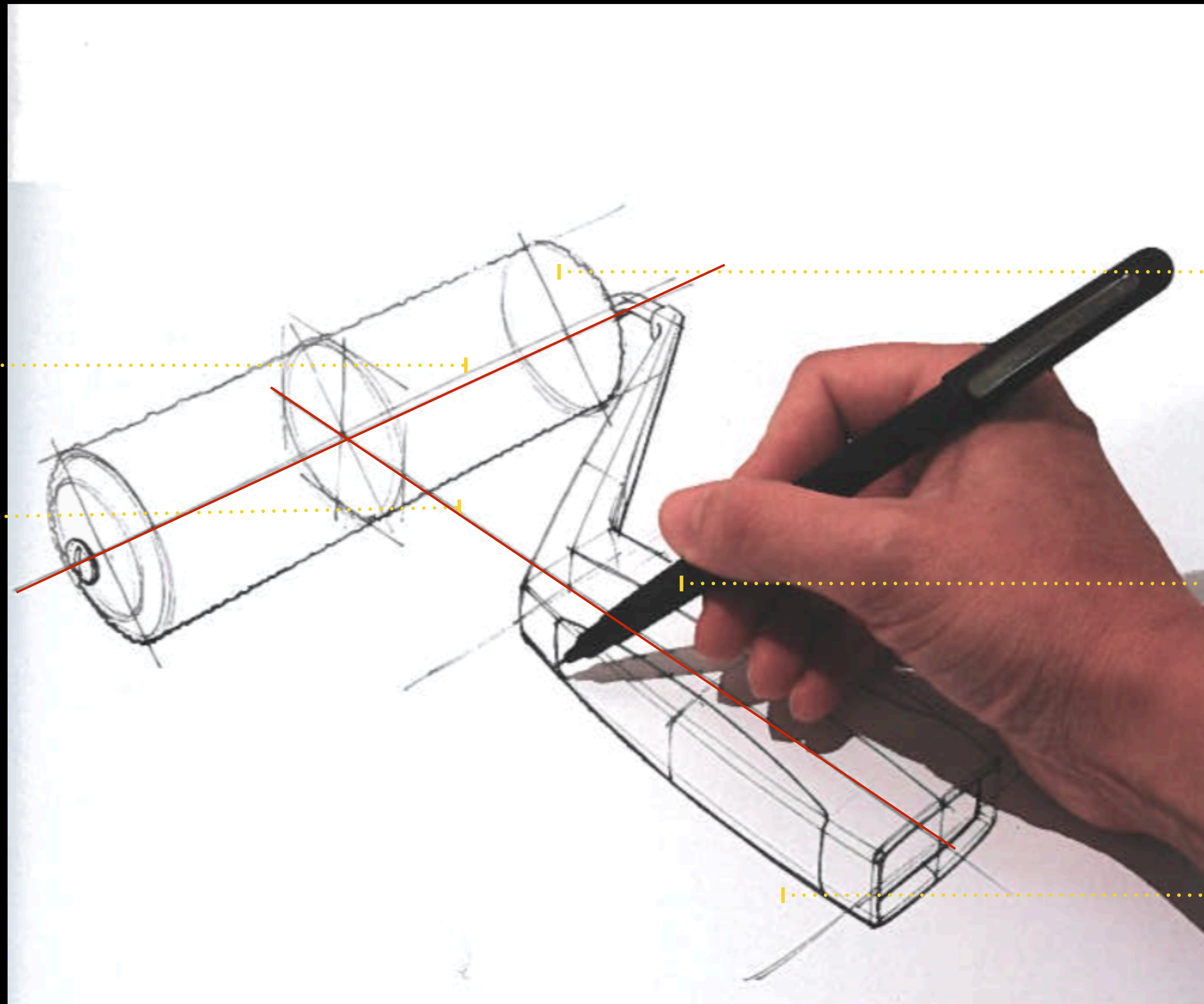

Axis II

Axis I

Cylinder

Cube

?

Construction Basic Shapes

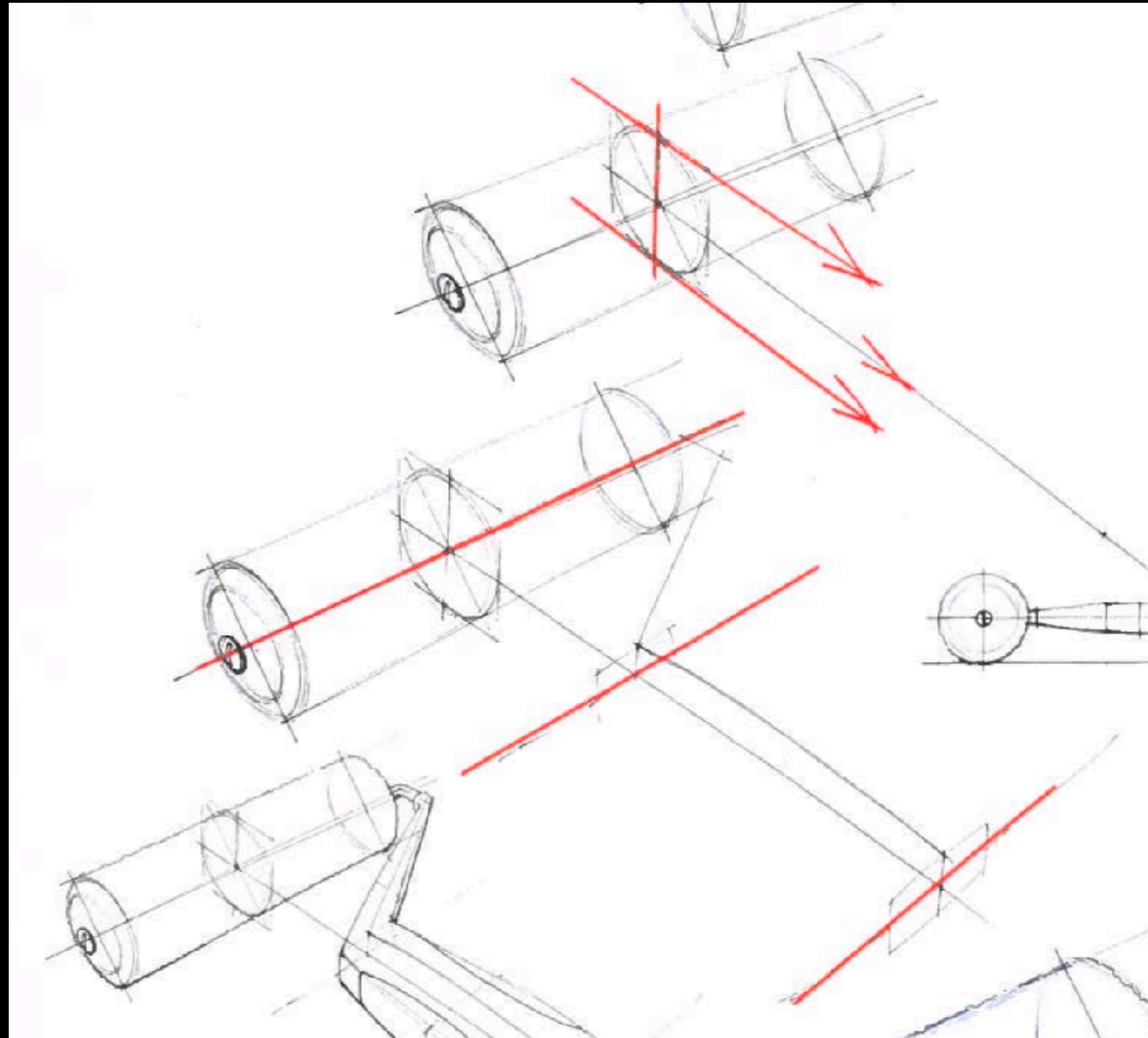

Rule 1

NO ERASER!

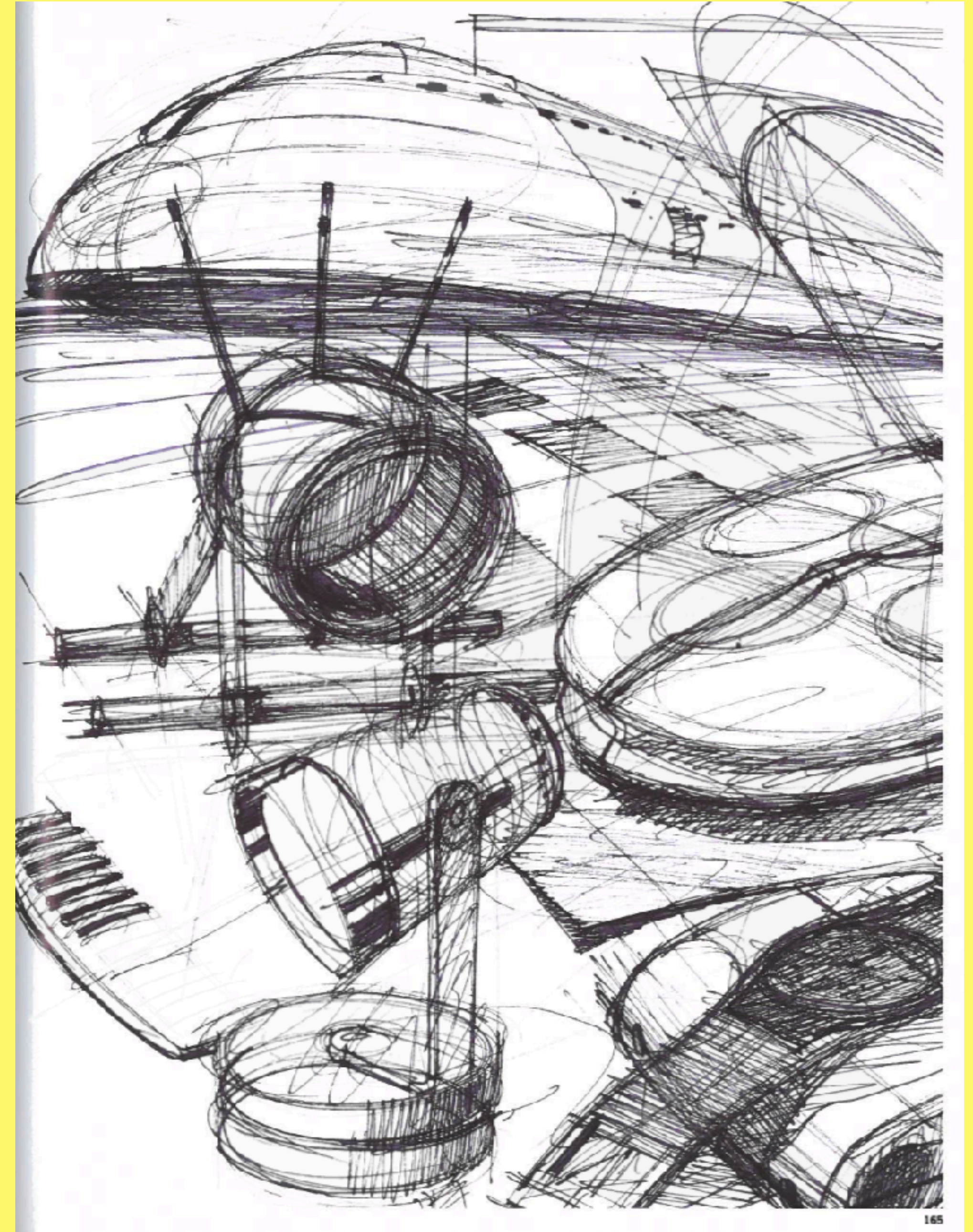

Rule 2

NO DIGITAL AID!

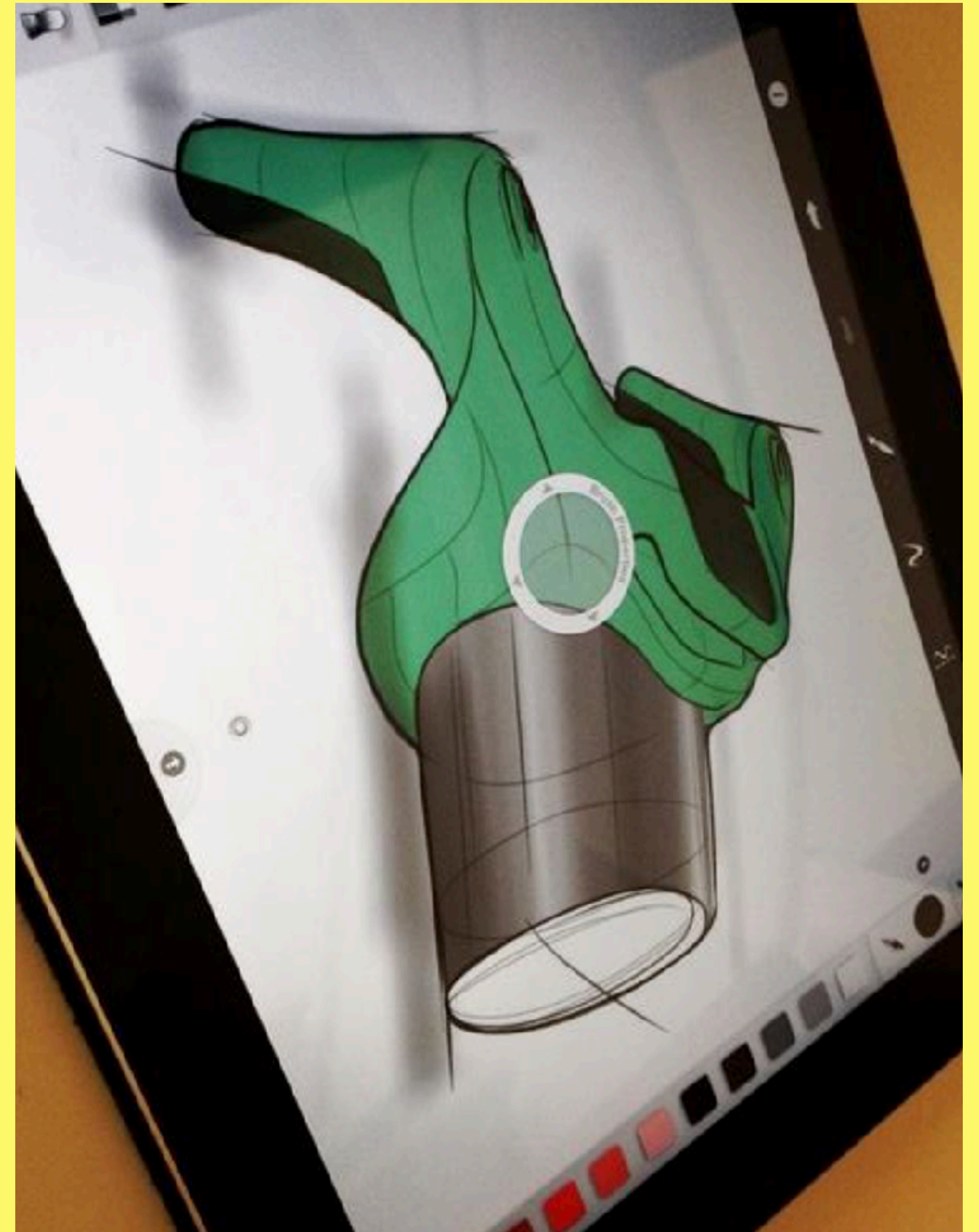

Exercise 1

Geometric Construction

1st Perspective - Main View

20 Minutes

SKETCHING

SURFACES - TENSION & FORCE

Construction
Basic Shapes

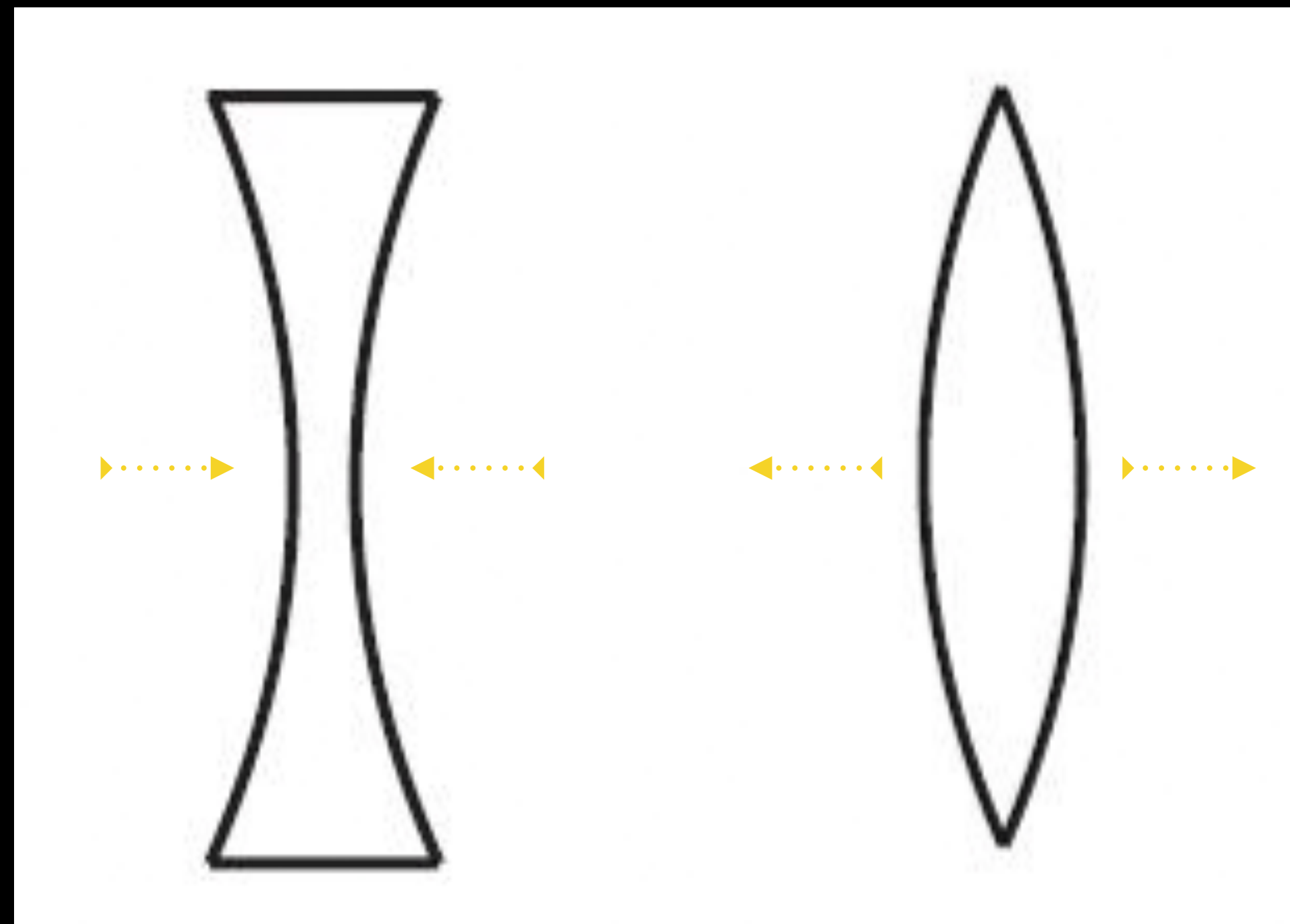
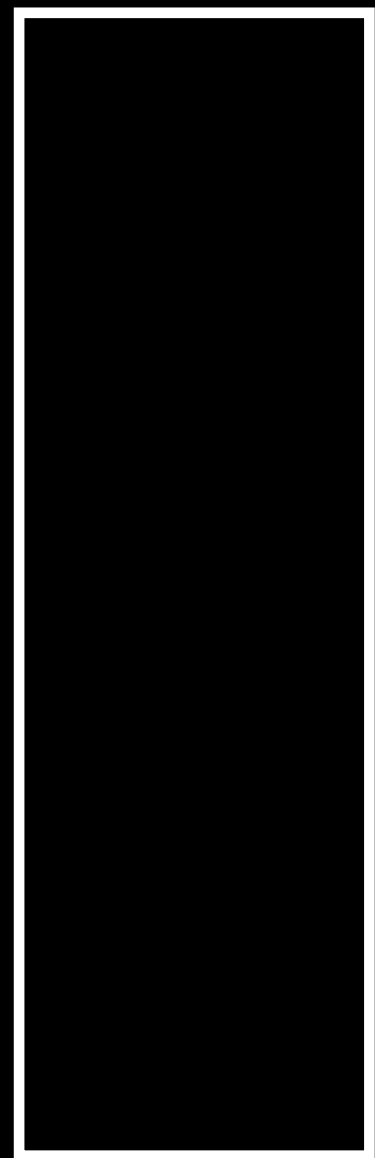

**Concave
Surface**

**Convex
Surface**

Surfaces

Directions & Force

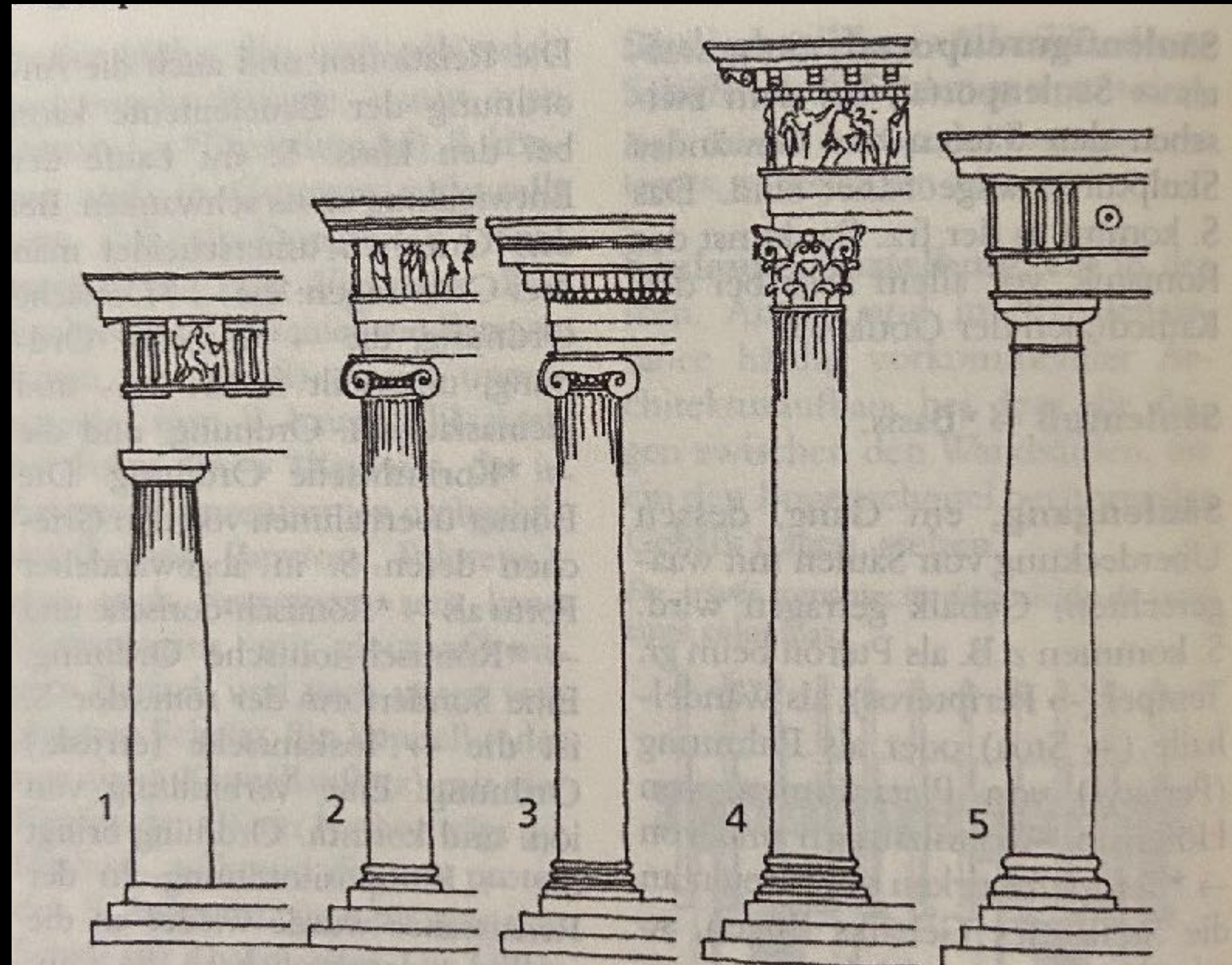

1. Dorische
Säule

7.BC Greek

3. Ionische
Säule

6.BC Roman

Surfaces

Ionic Column

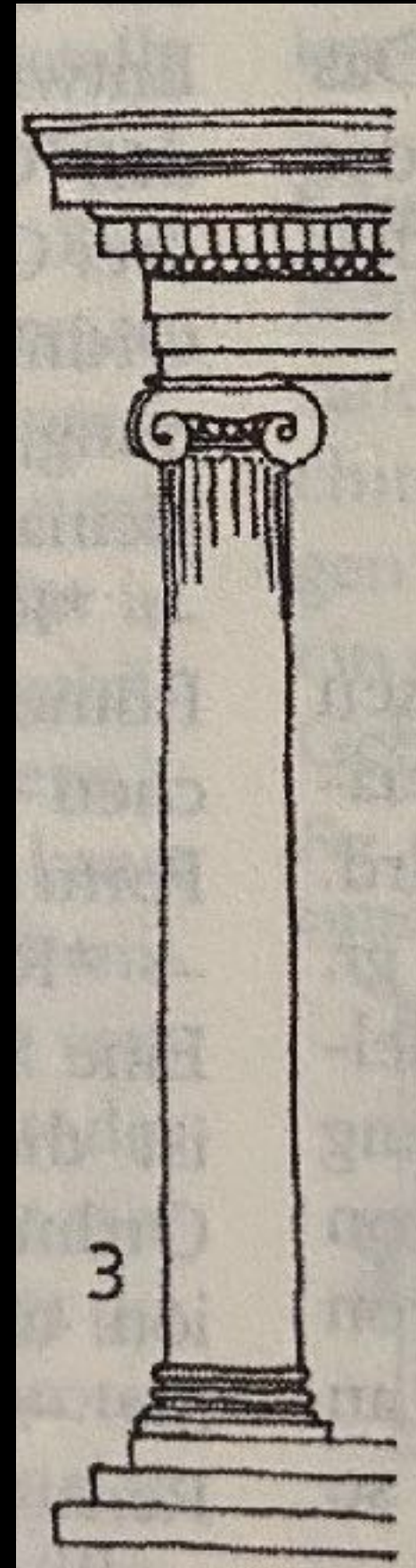

7.BC Greece



Apollon Temple
Ionic Temple Didmya
5. BC

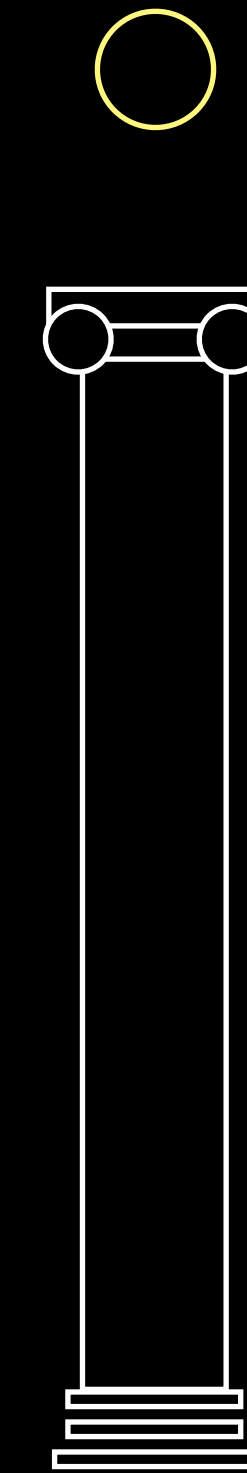

Surfaces

Doric Column

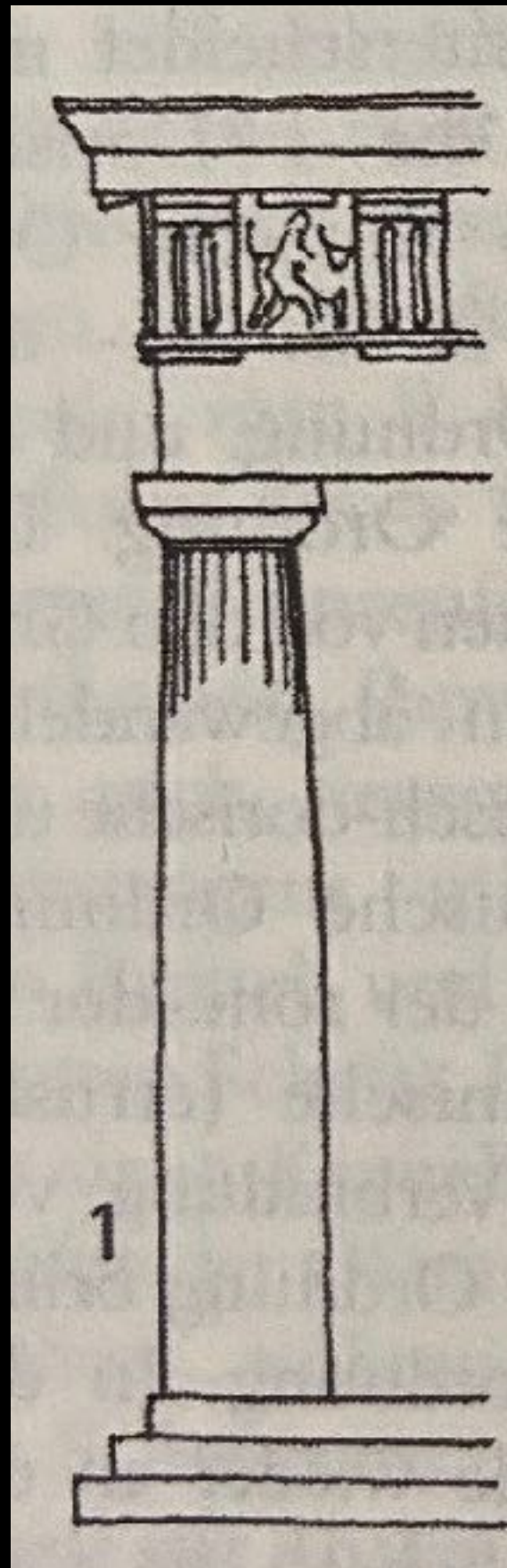

7.BC Greece



Temple of Poseidon
Doric Temple Paestum
„Magne Graecia“ 6. BC

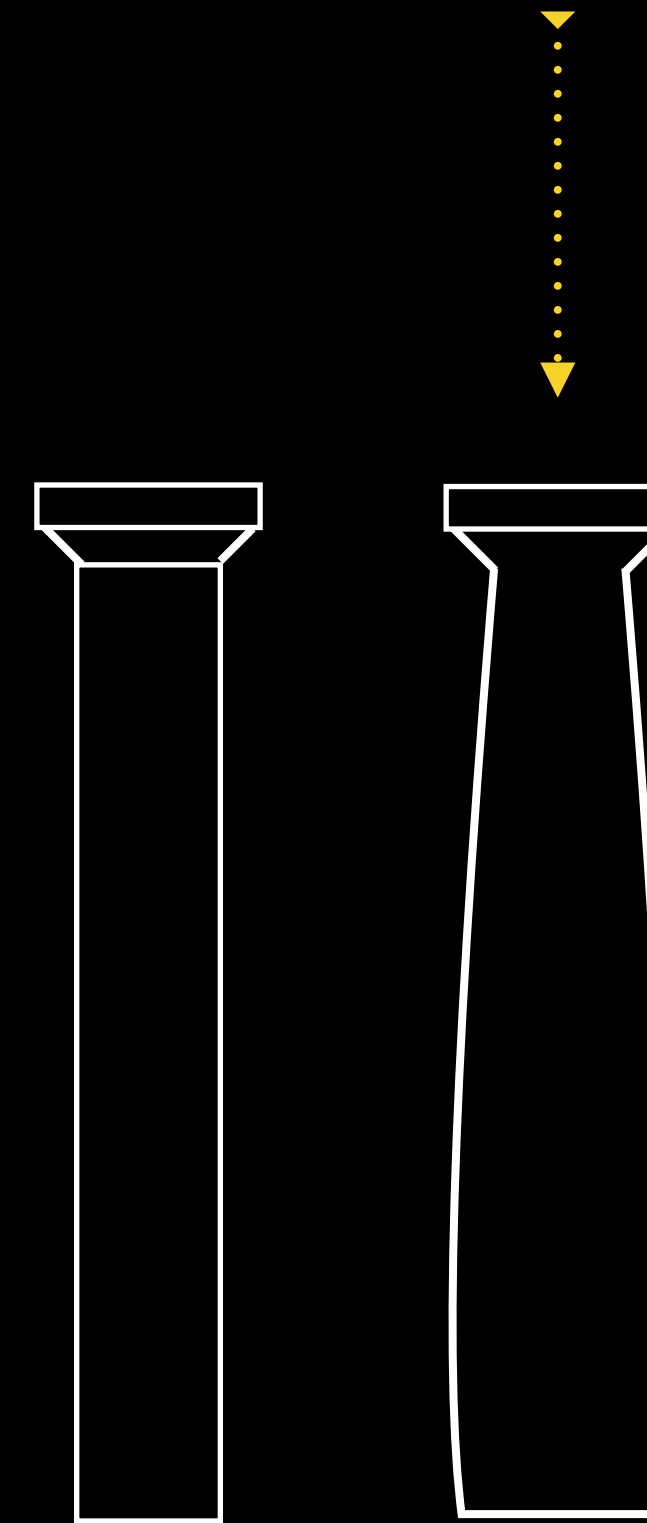

Surfaces

Directions & Force

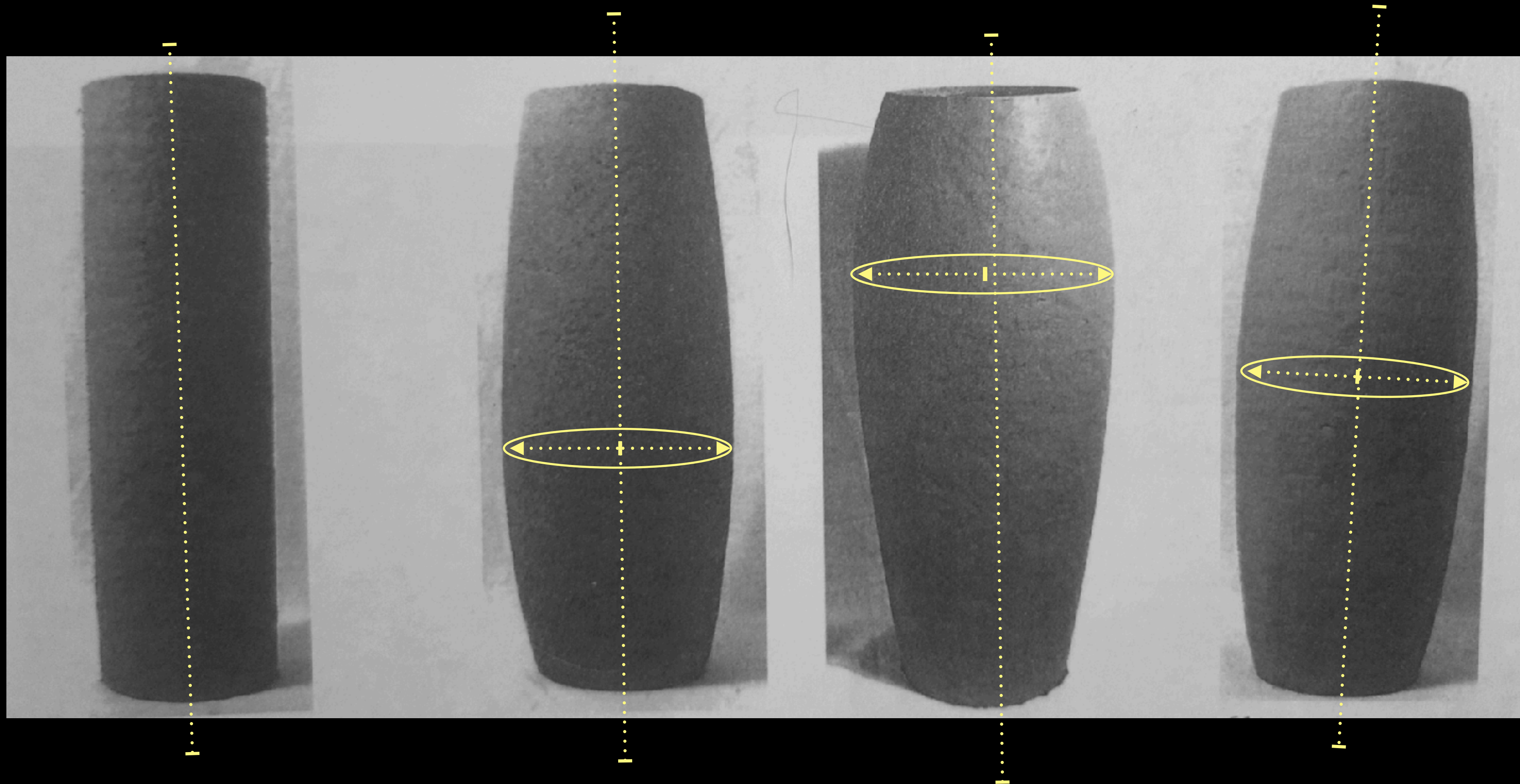

Surfaces

Directions & Force

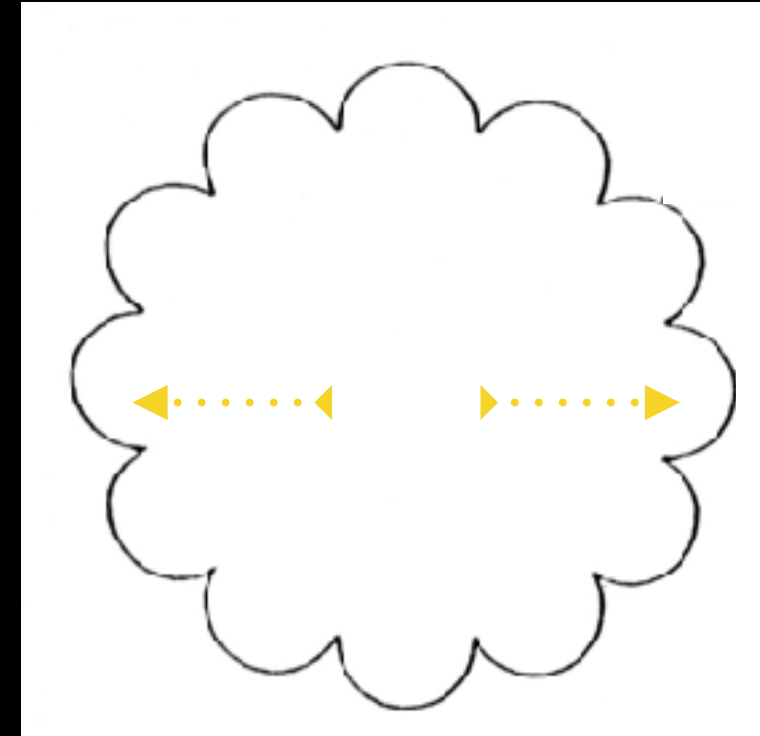

**Convex
Surface**

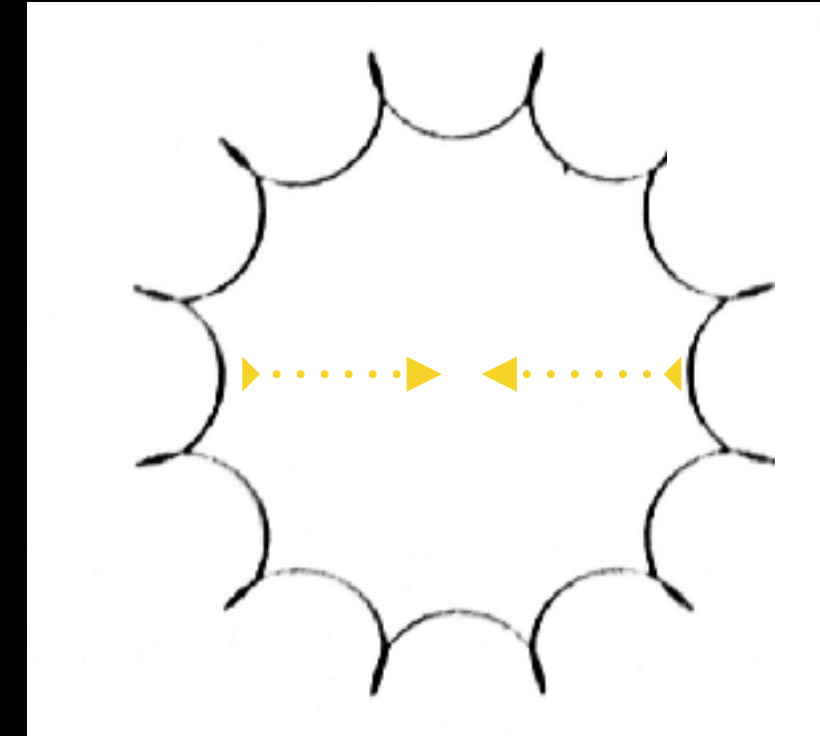

**Concave
Surface**



**Rotating
Surface**

Construction
Forces & Tension

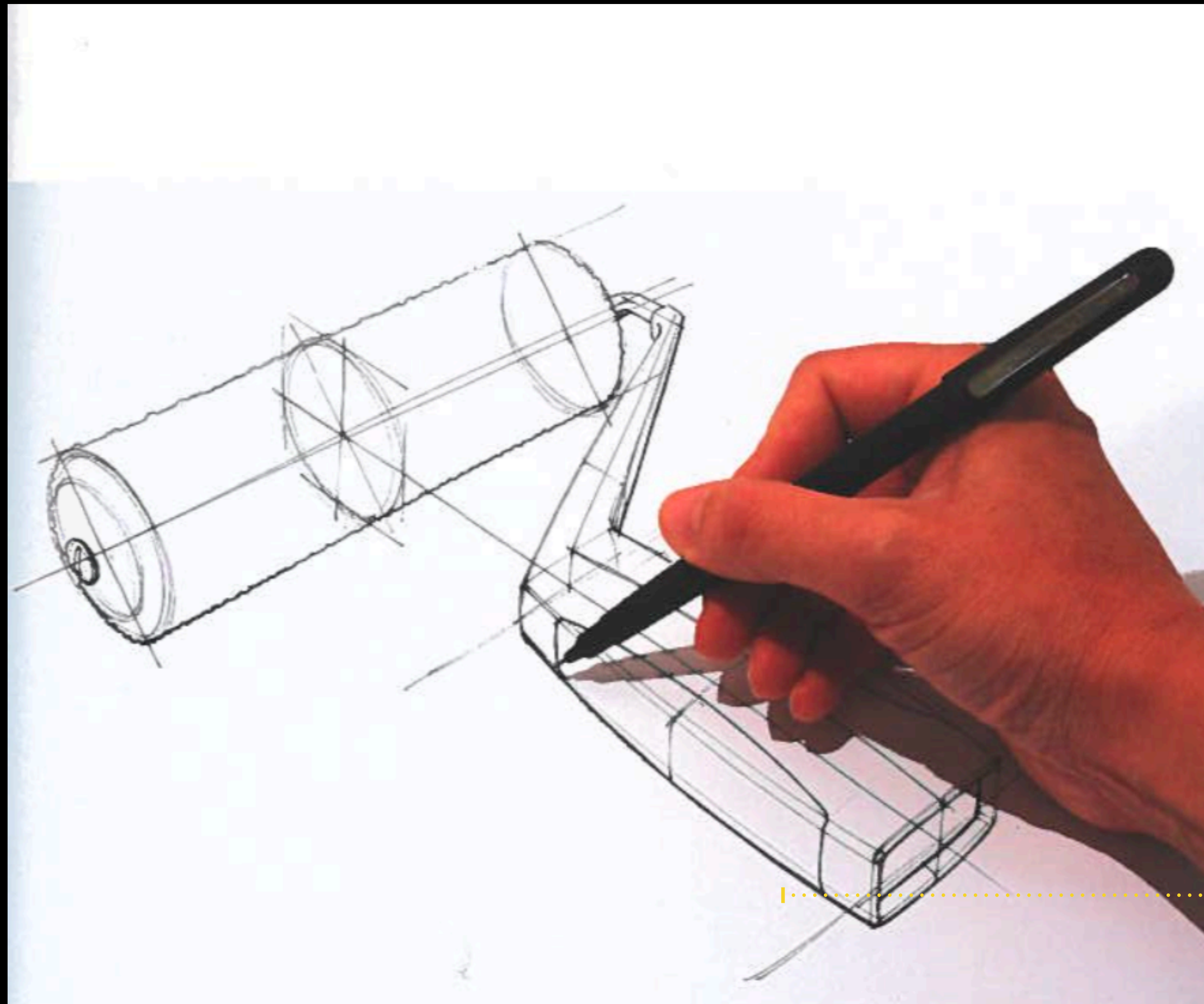

Convex Surface

Exercise 2

Curves

**2nd Perspective - Pay attention
to the direction of force on the
object**

Construction

SHAPE DEVELOPMENT



Construction

SHAPE DEVELOPMENT

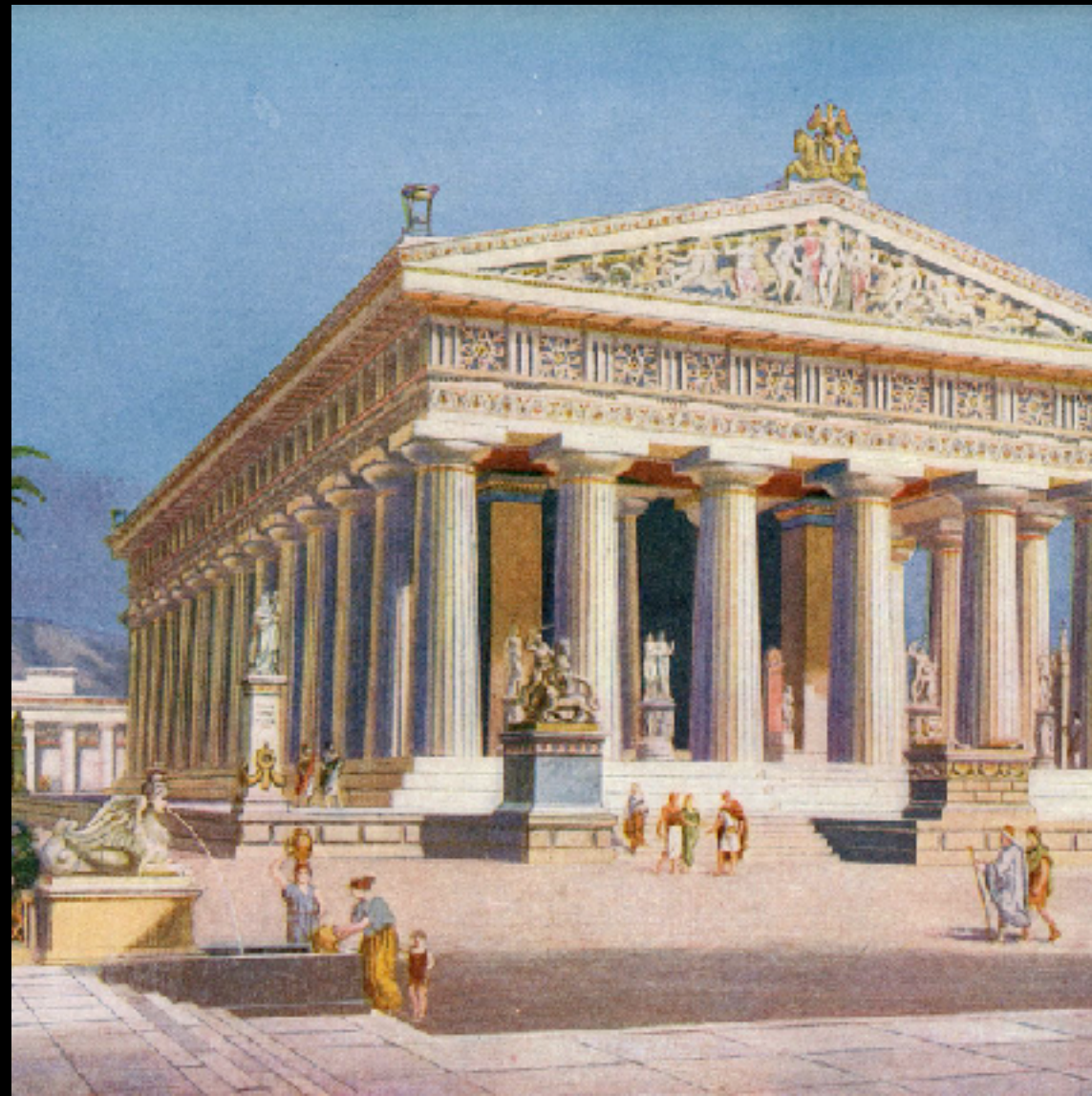

Construction

SHAPE DEVELOPMENT



SKETCHING

SHADOWS

Construction
SHADOWS

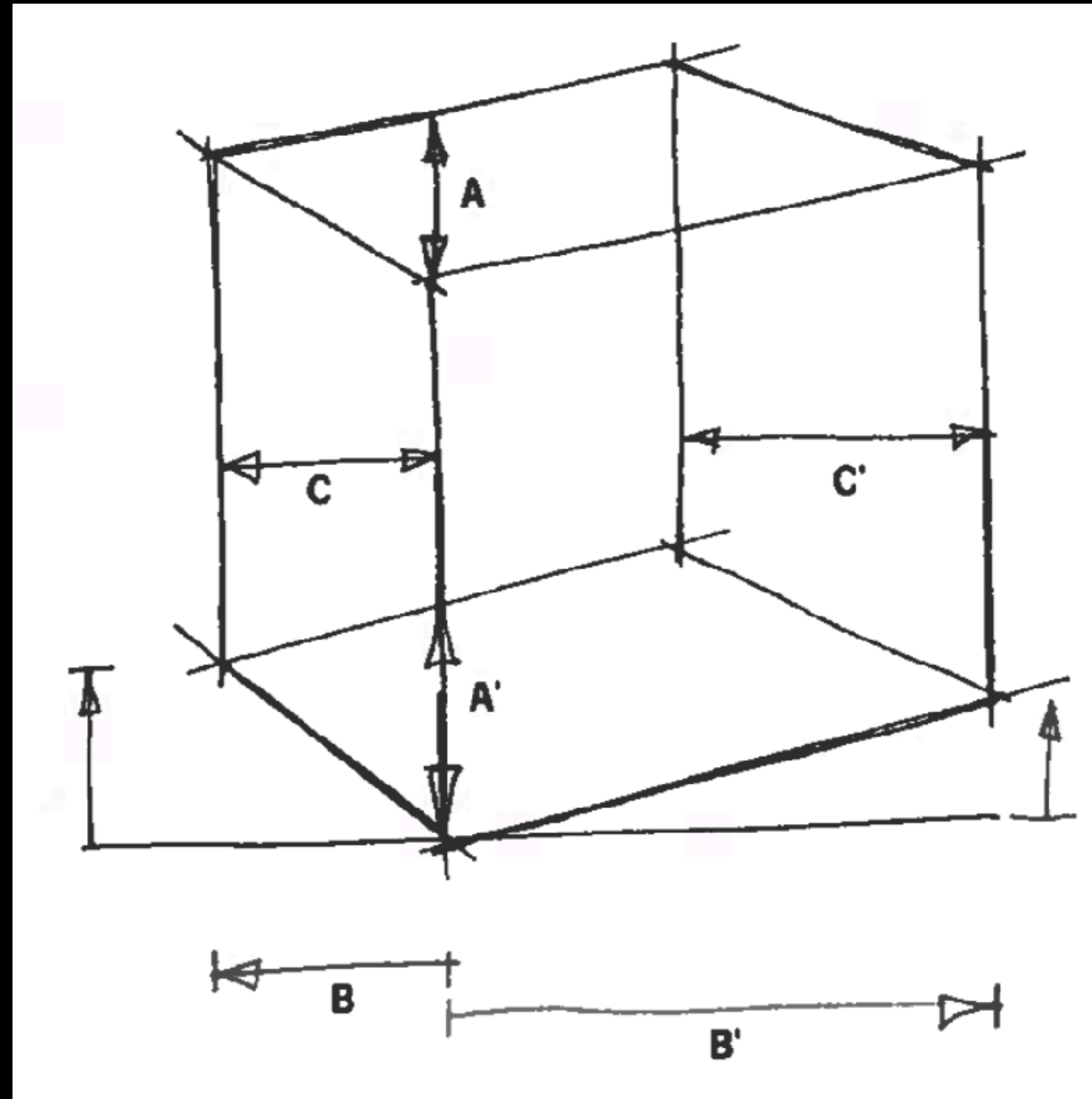

Construction SHADOWS

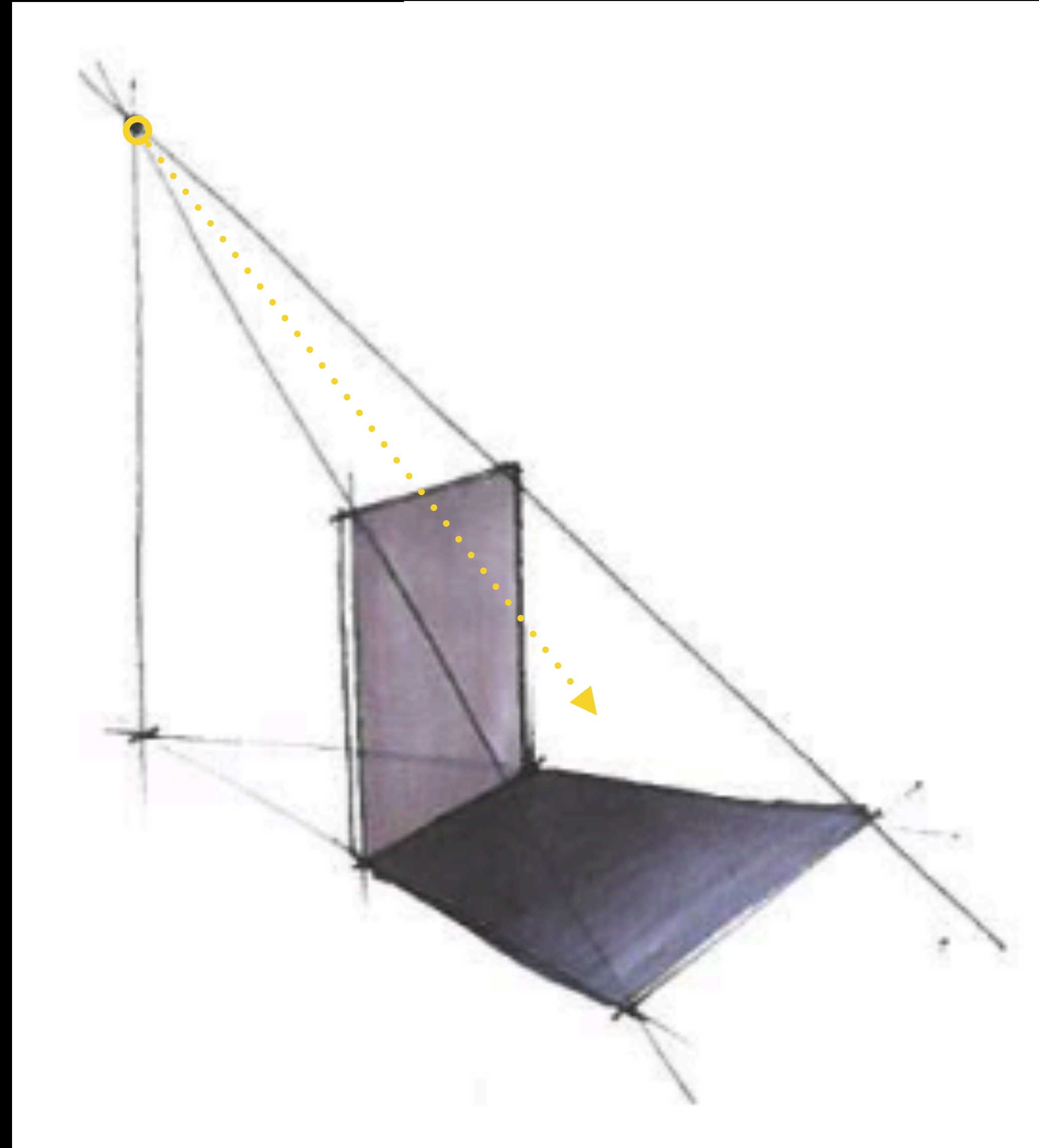

Construction SHADOWS

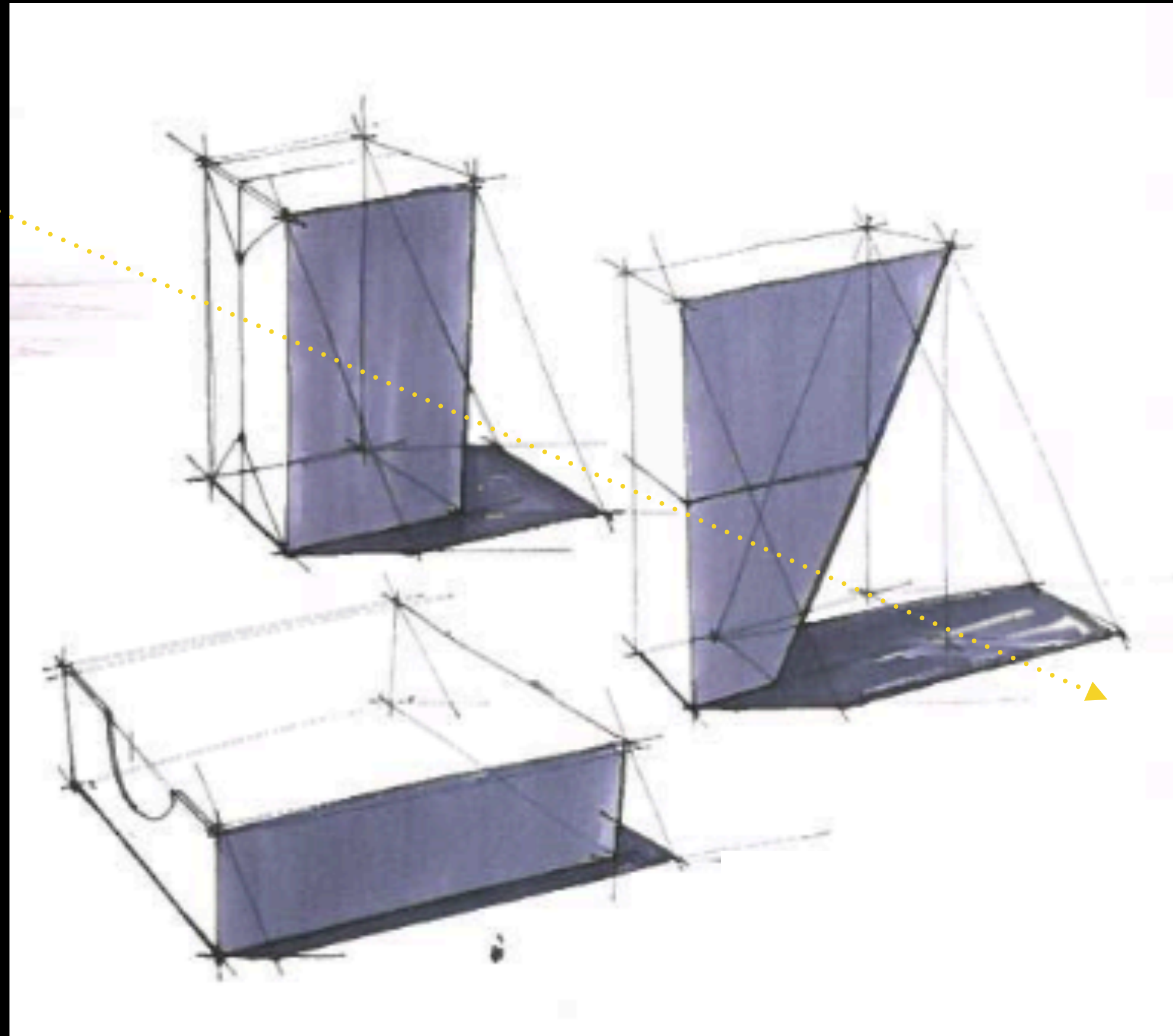

Construction SHADOWS

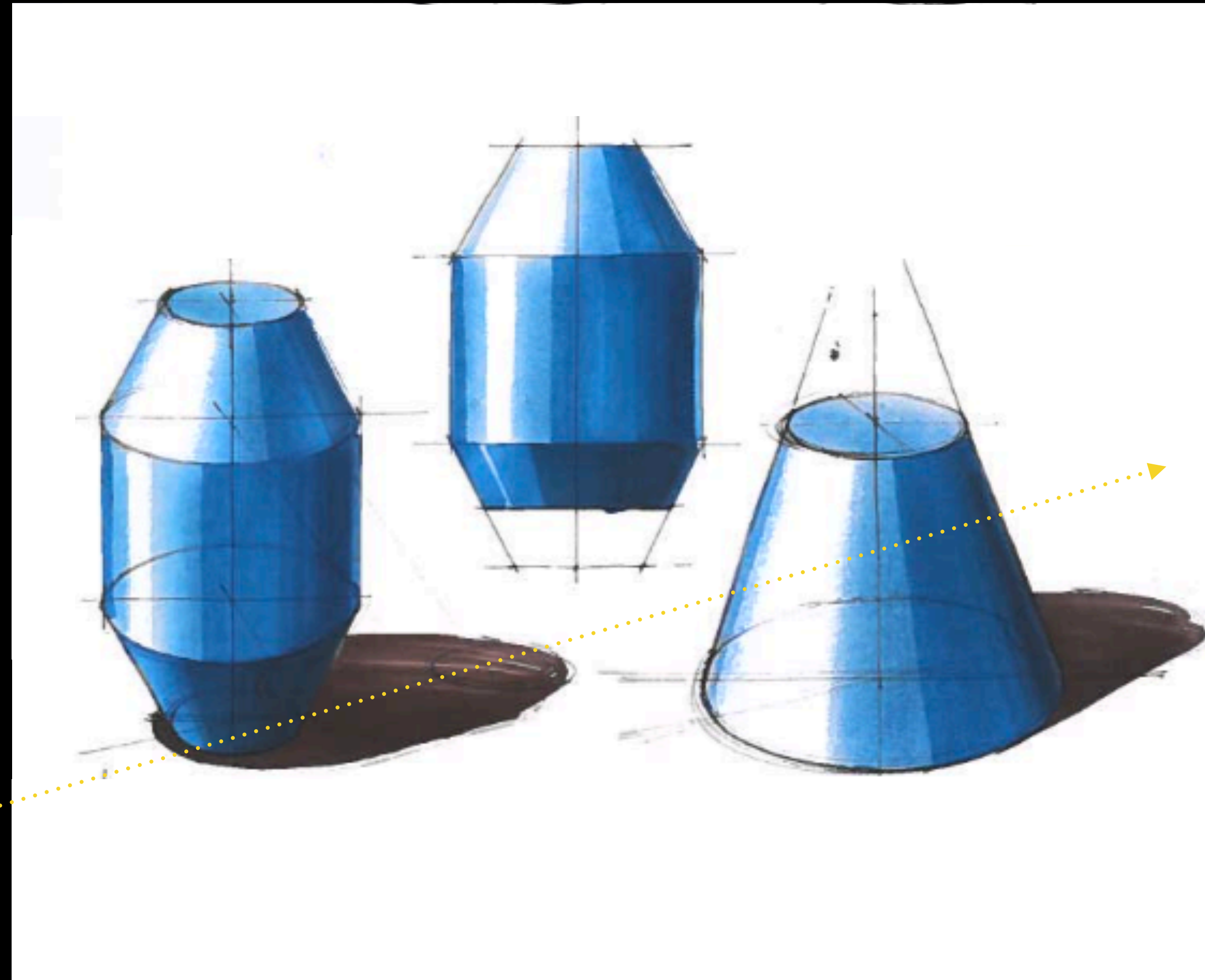

Construction SHADOWS

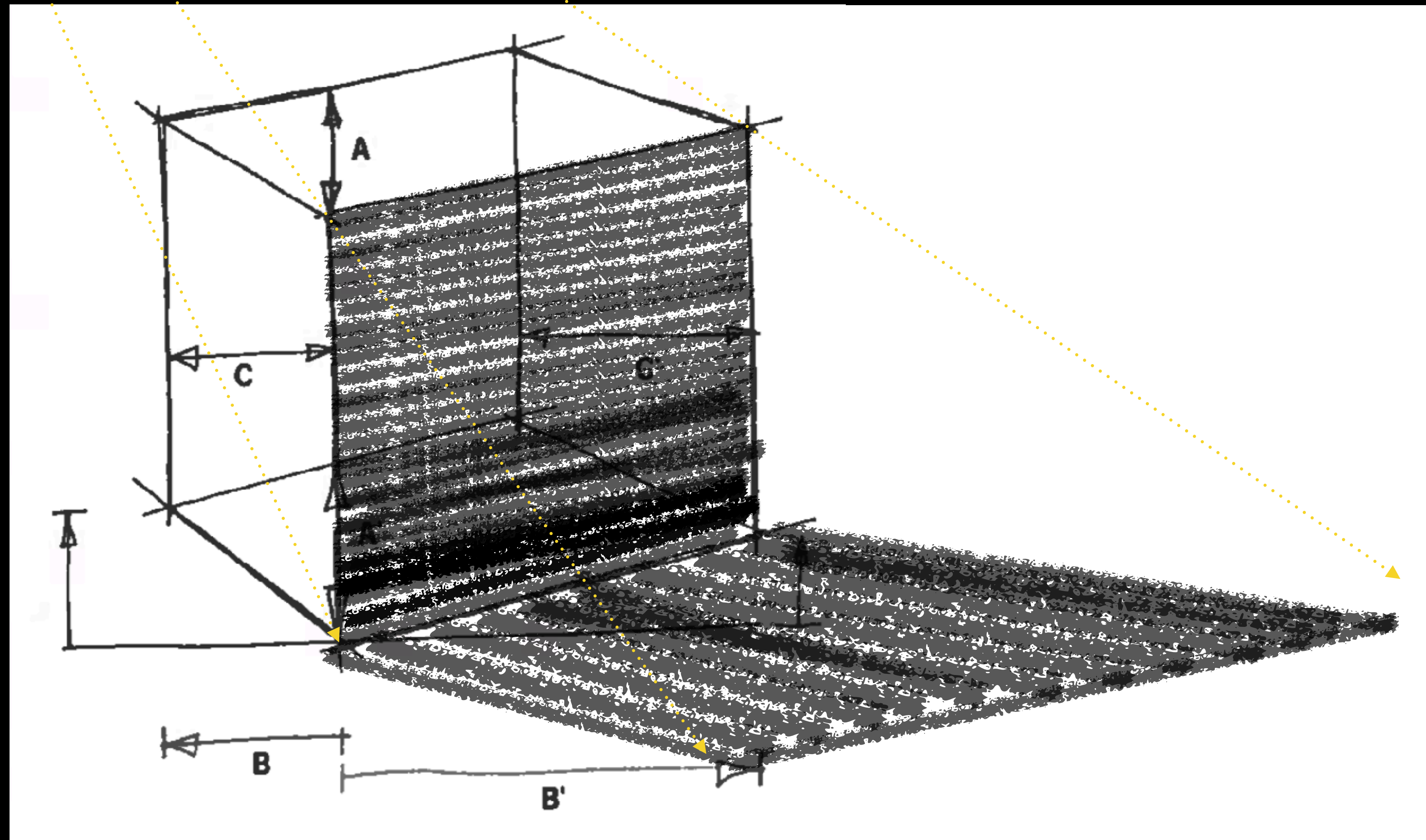

Construction SHADOWS

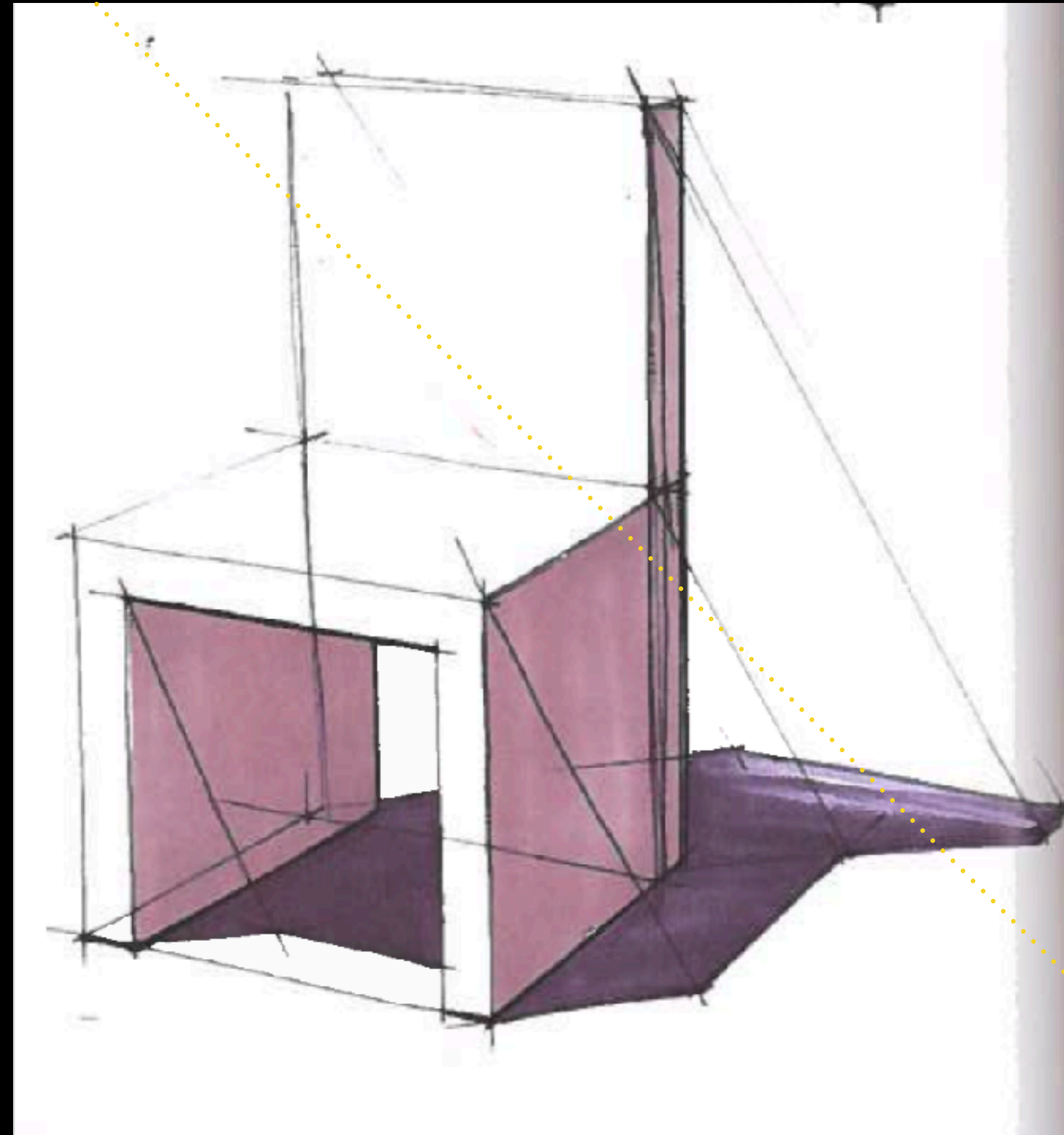

Construction
SHADOWS



Construction
SHADOWS

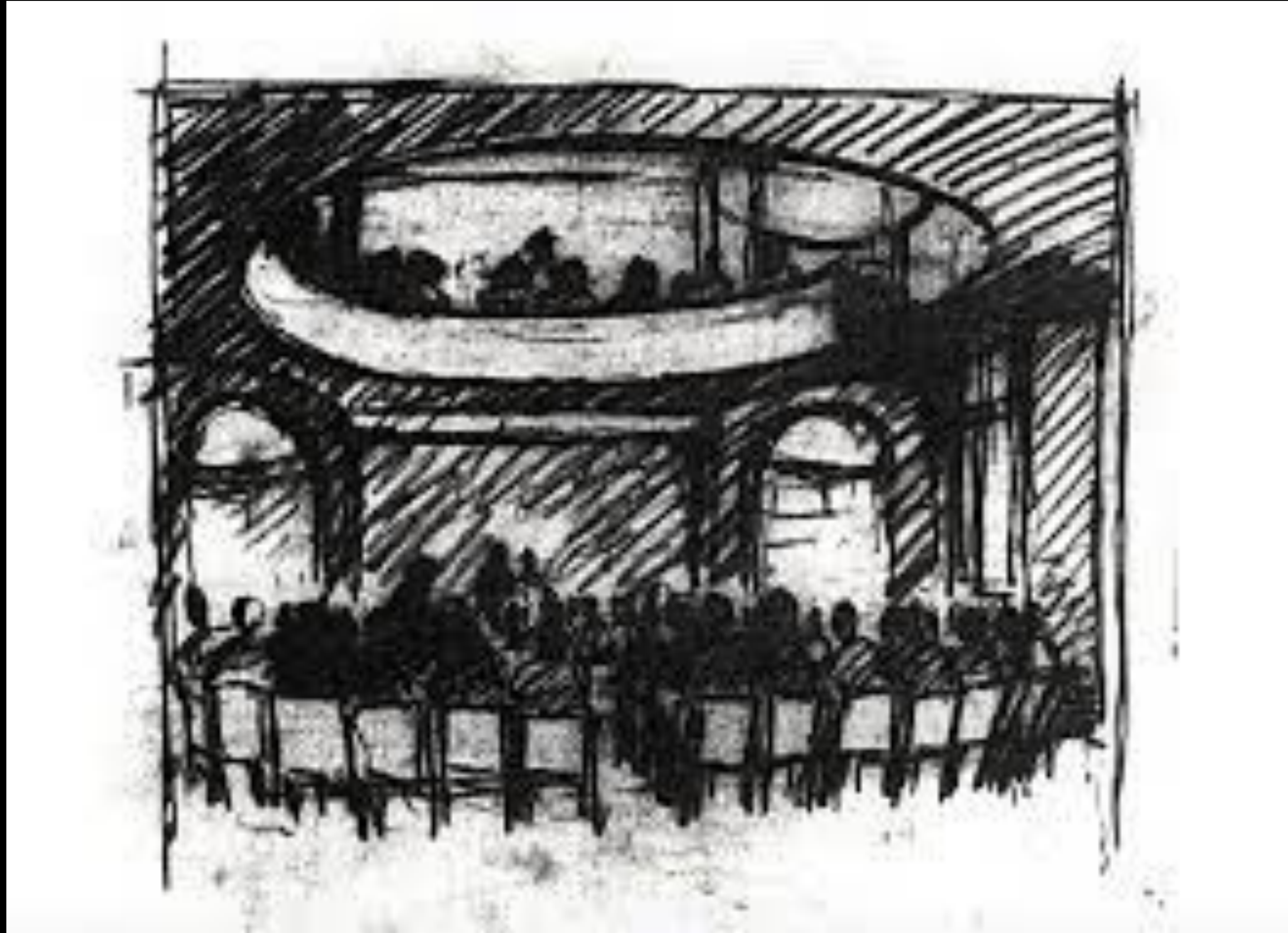

Exercise 3

Shadowing

**2nd Perspective - Pay attention
to the direction shadows**

SKETCHING

SECTIONS

Construction
SECTIONS

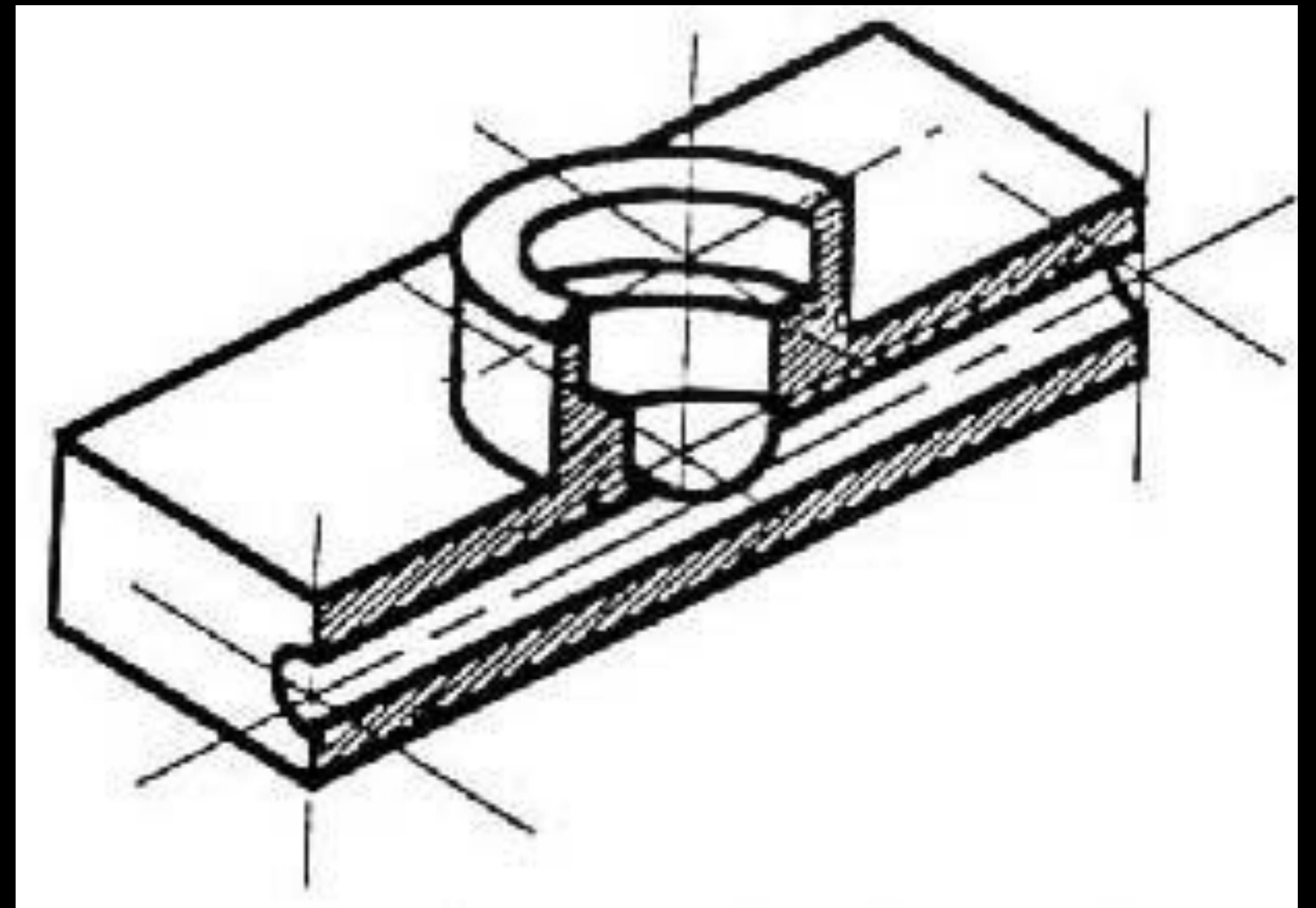
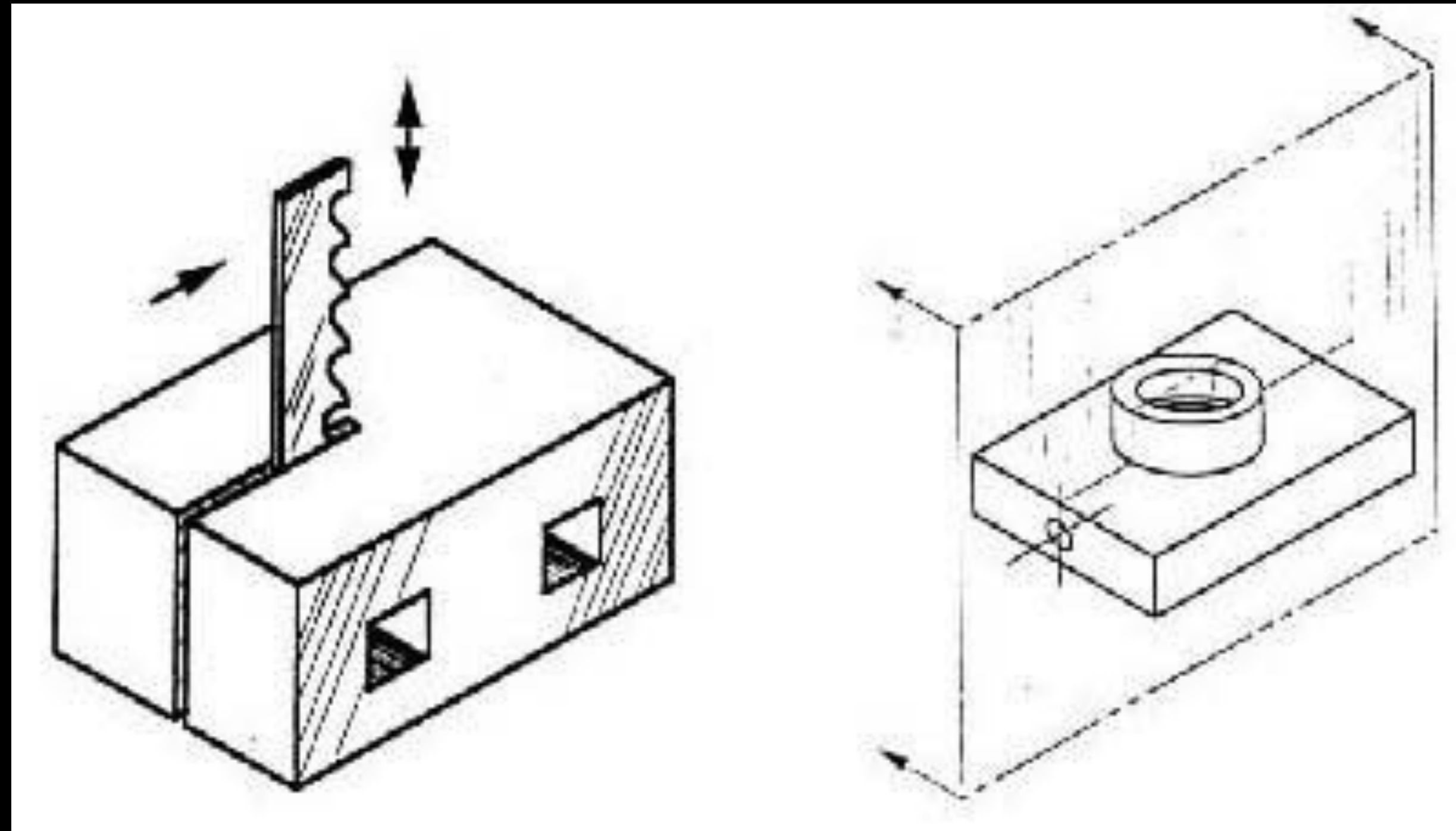

Construction SECTIONS

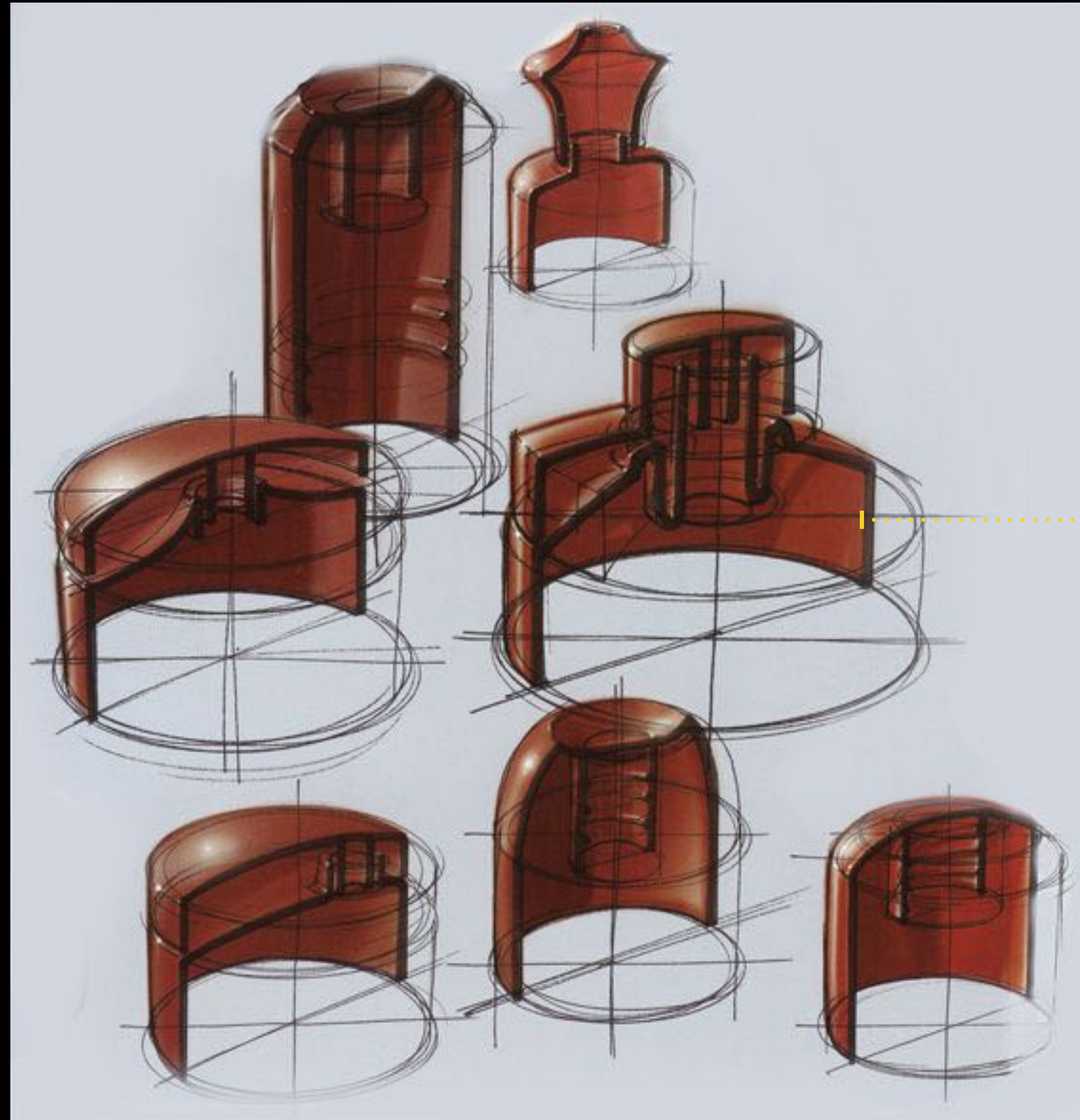

1.

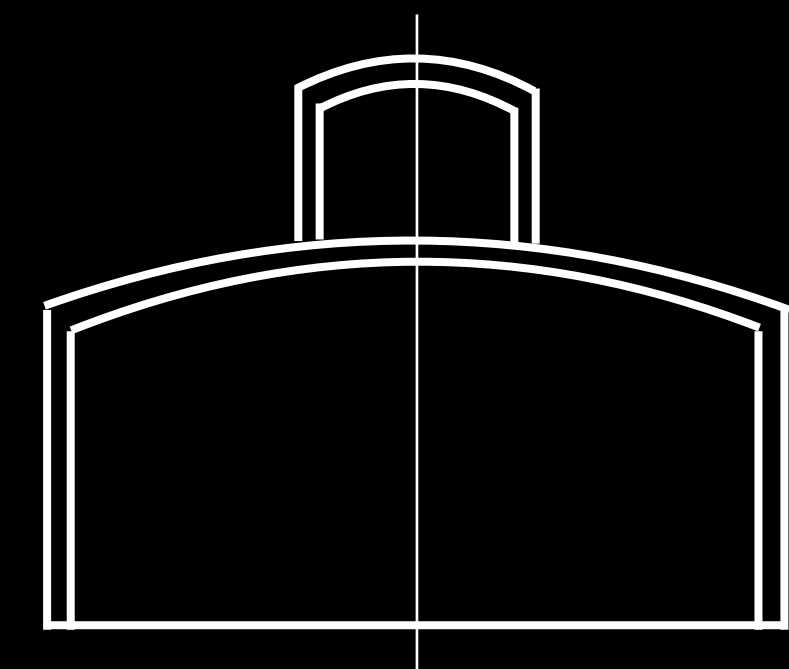

Exercise 4

1 minute Sections

**Sketch three objects to cut
through**

3 Minutes

Exercise 5

Sections

**3rd Perspective - Imagine a cut
through your object**

Exercise 23Shadowing

**3rd Perspective - Pay attention
to the direction shadows**

Storytelling

DOODLE TO SCRIBBLE



doodle + scribble

Storytelling

DOODLE TO SCRIBBLE TO SKETCH

WHAT'S THE DIFFERENCE?!



Exercise 5

SKETCH YOURSELF!

45 Minutes

Storytelling

Sketch Yourself



Storytelling

HOW I DISCOVERED WHAT I WANT TO DO



Storytelling

HOW WE DO MUSIC



5 Minute Concept → 3 Minute Rehearsal → 6 Minute Shooting / Person → 10 Minutes editing

Exercise 5

GROUPS OF 2:

„HOW I CAME TO I.A.D.“

VIDEO (max. 3 min + SKETCH)

30 Minutes

SKETCHING

FOCAL POINT

Construction Strokes

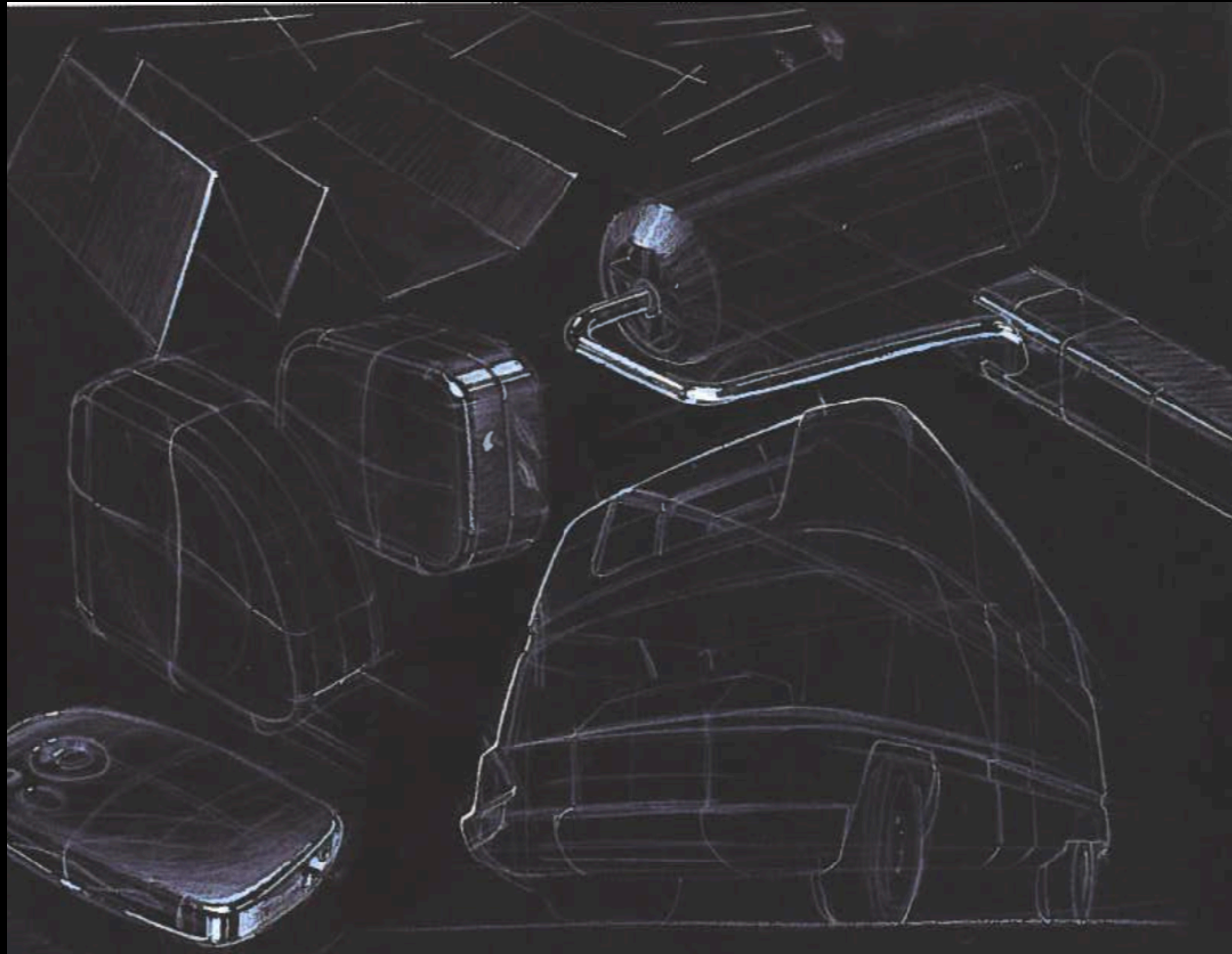

Construction Coloring

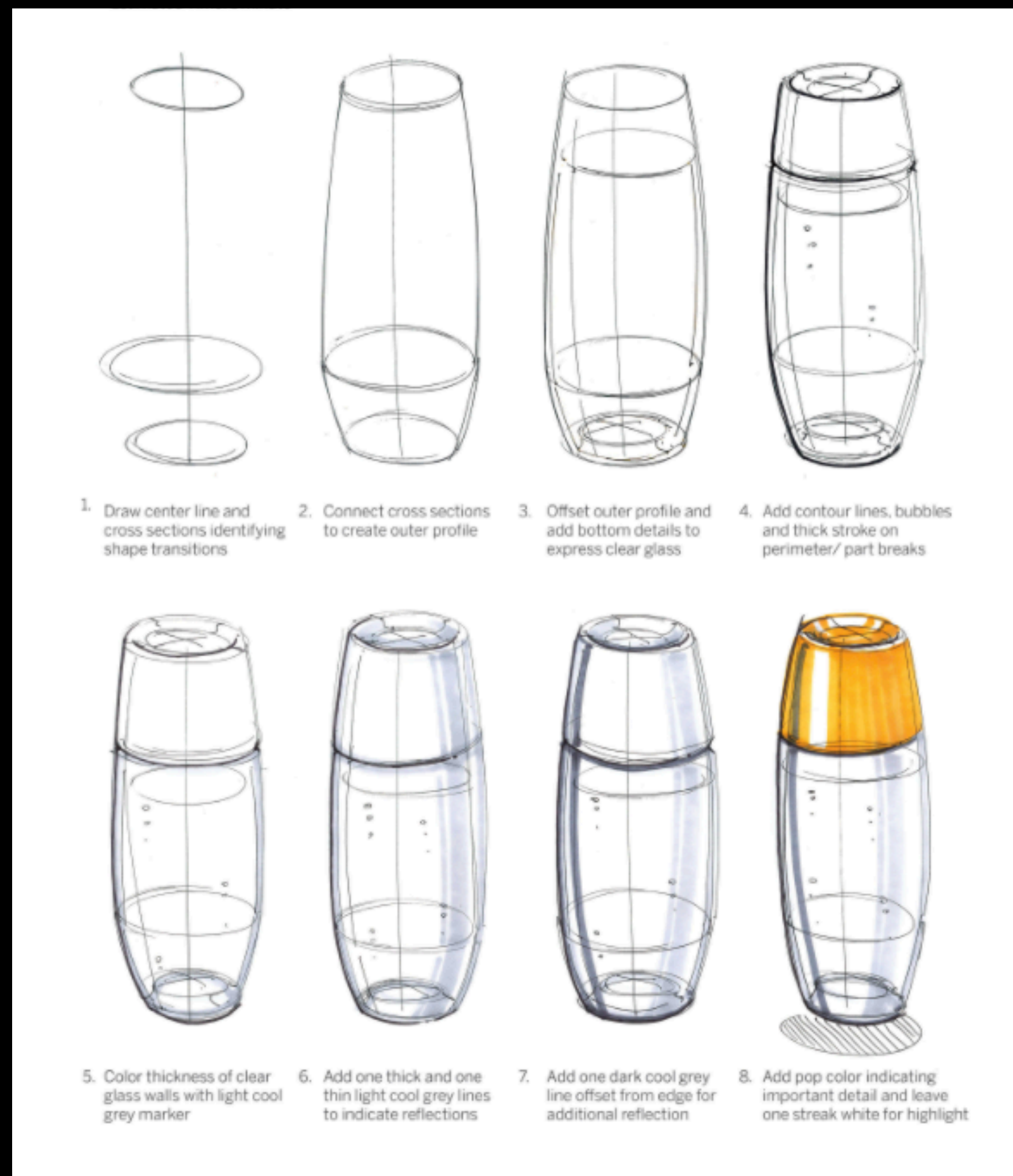

Construction
Focal Points

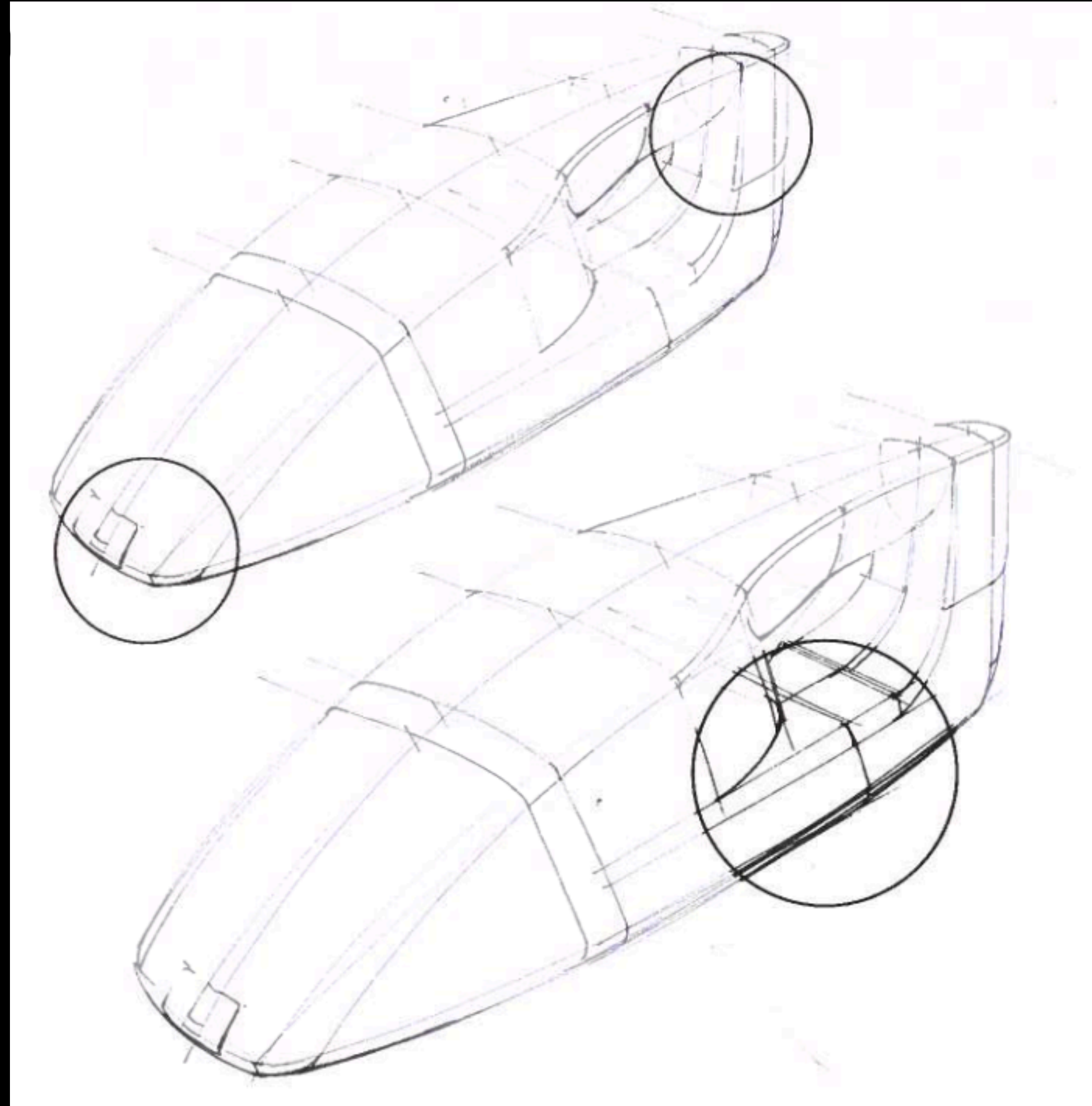

Exercise 6

Strokes & Focal Point

**3rd Perspective - Pay attention
to thickness of lines and focal
points**

BREAK!

SKETCHING

**FUNCTIONS / NOTES /
ARROWS**

Construction

FUNCTION / NOTES / ARROWS

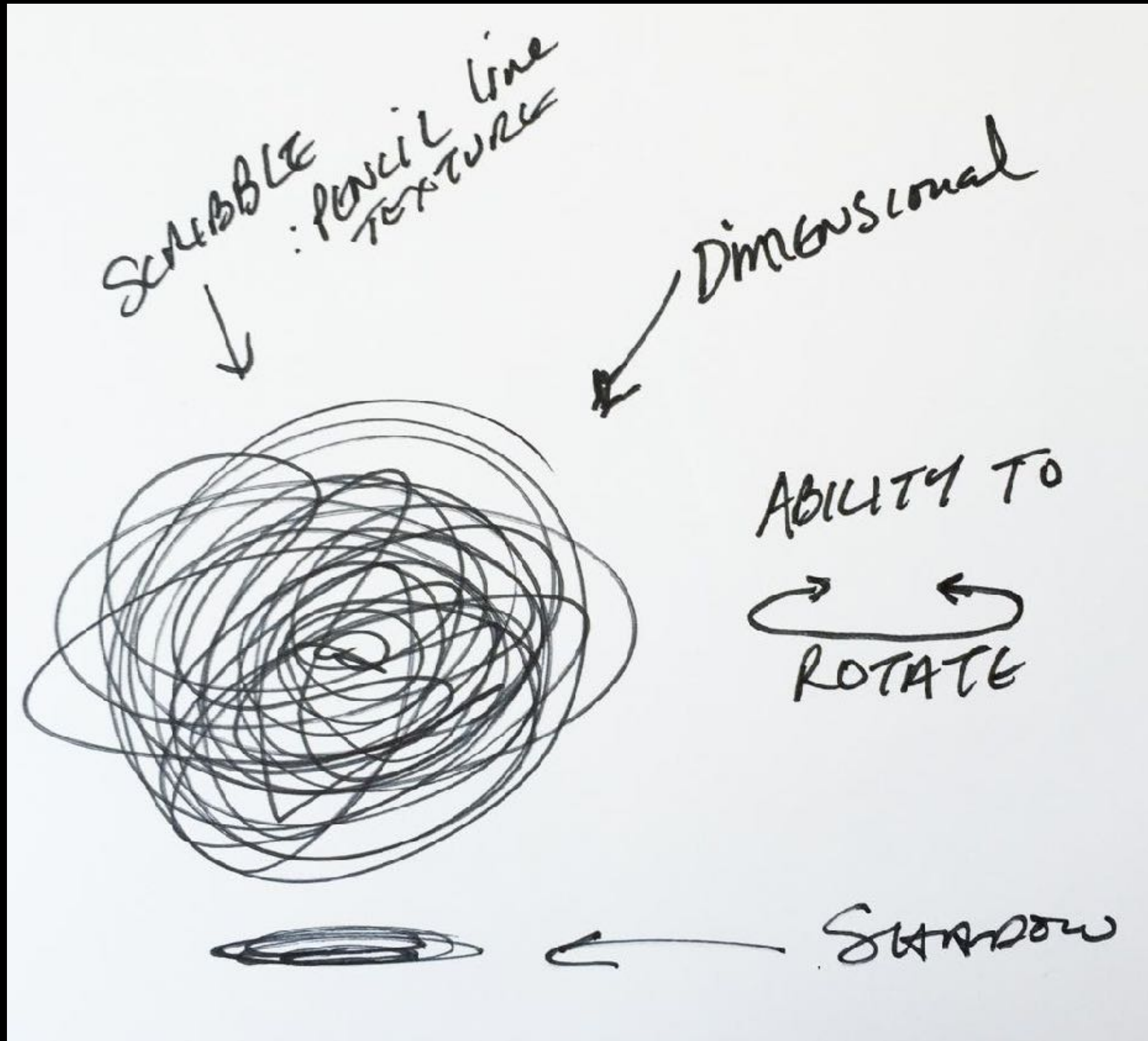

Construction

FUNCTION / NOTES / ARROWS

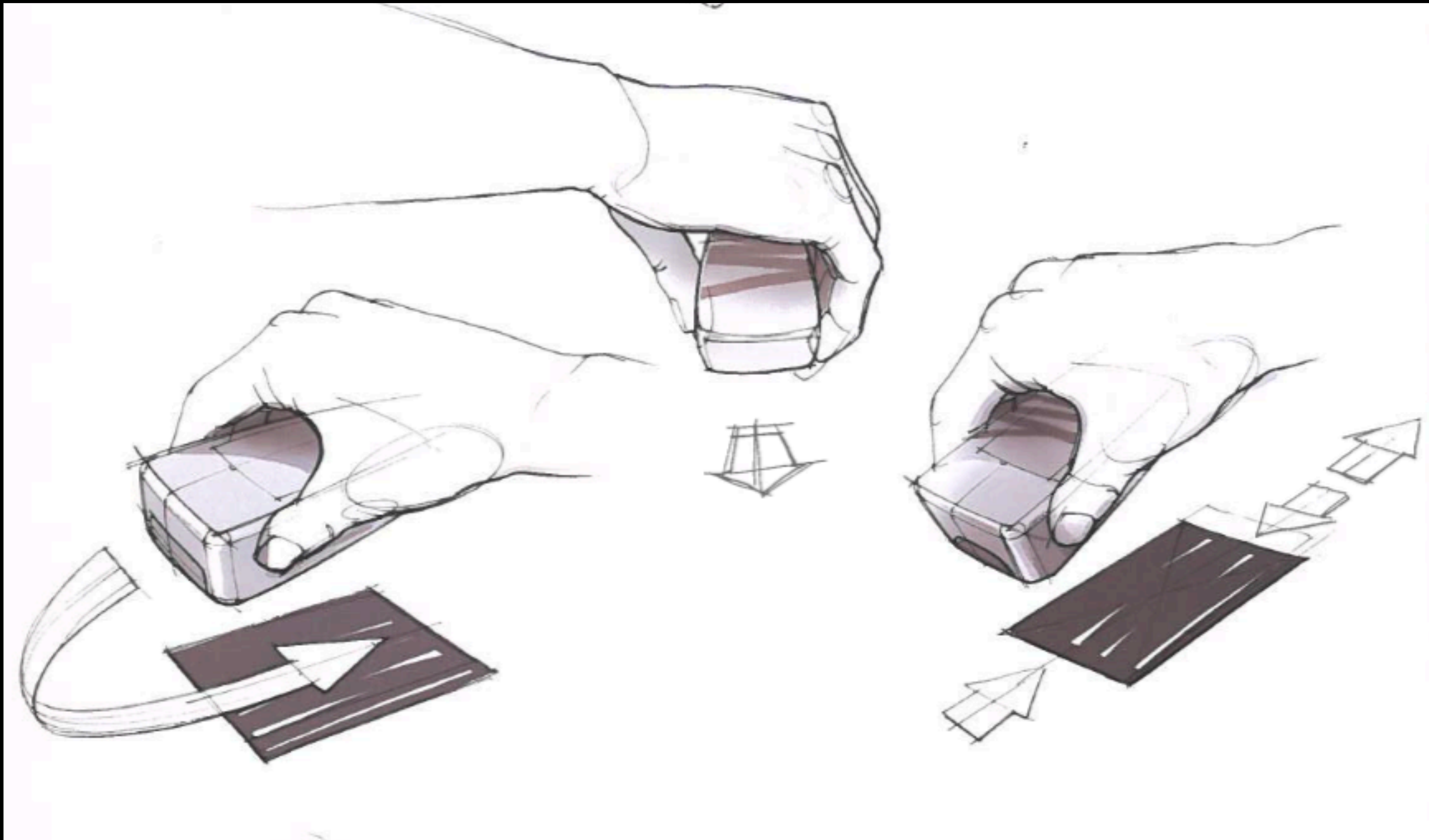

Construction

FUNCTION / NOTES / ARROWS

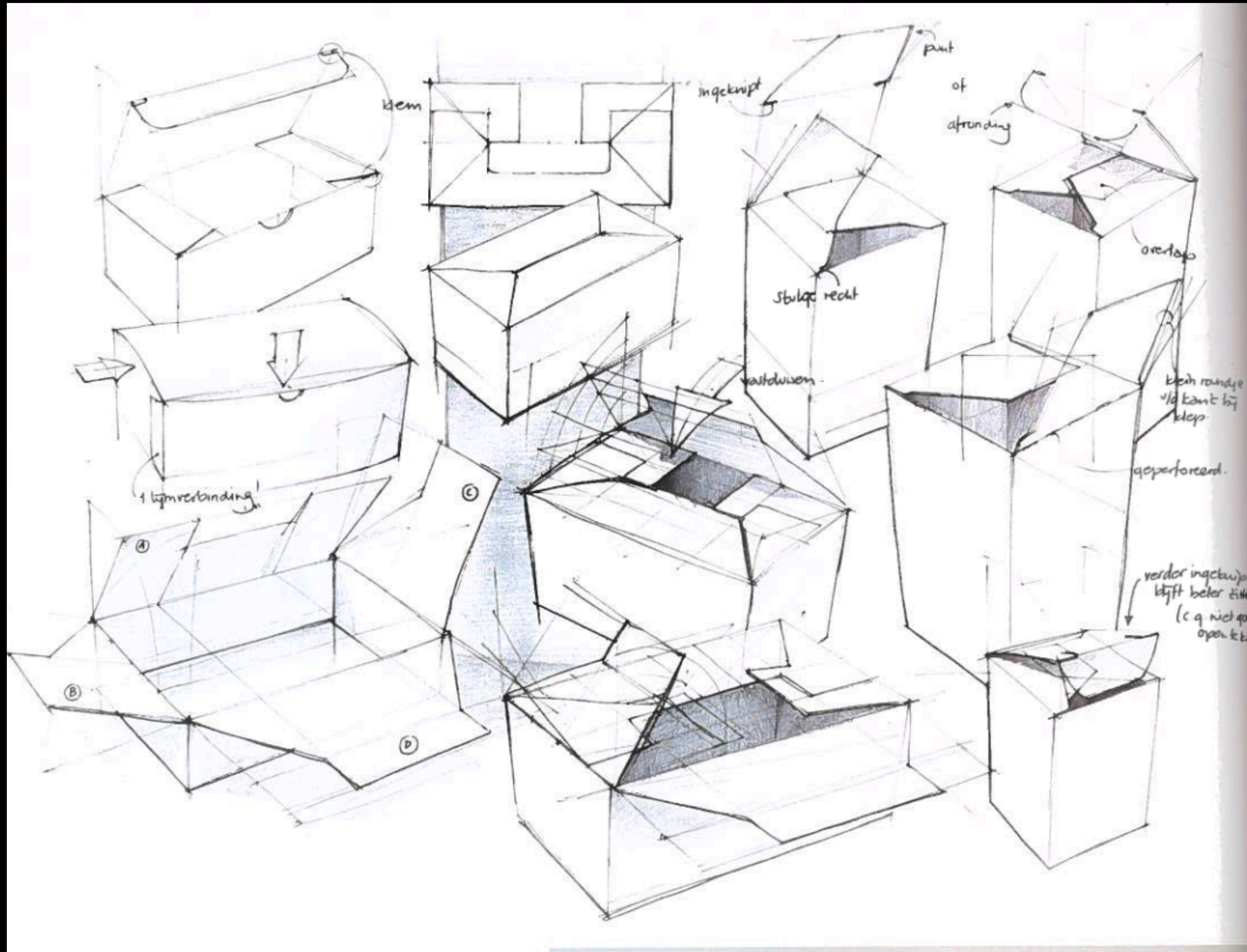

Exercise 7

FUNCTIONS & ARROWS

Integrate some functions

5 Minutes

SKETCHING

COLORING

Highlight Light

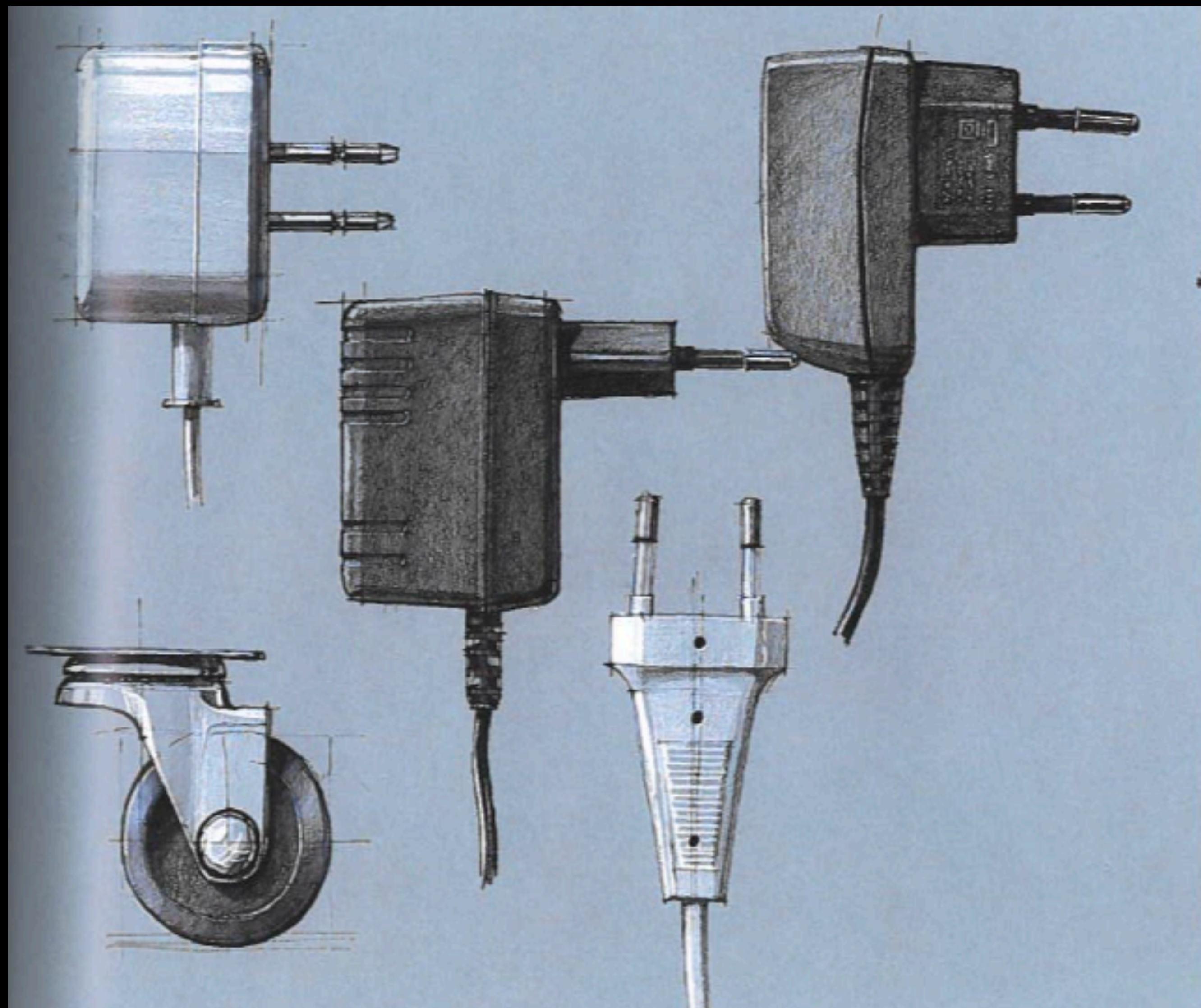

Highlight
Selected Coloring

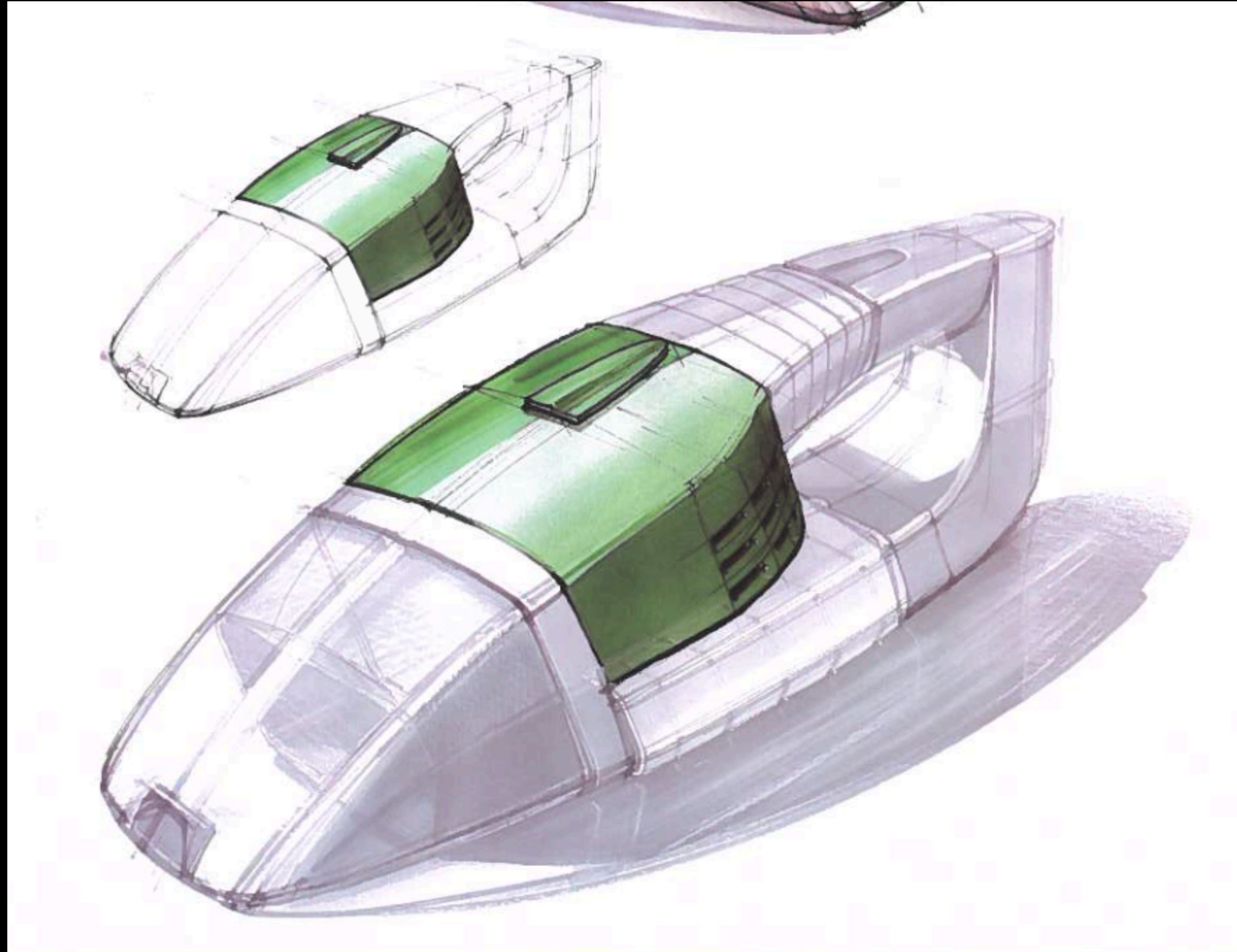

Highlight Colored Background

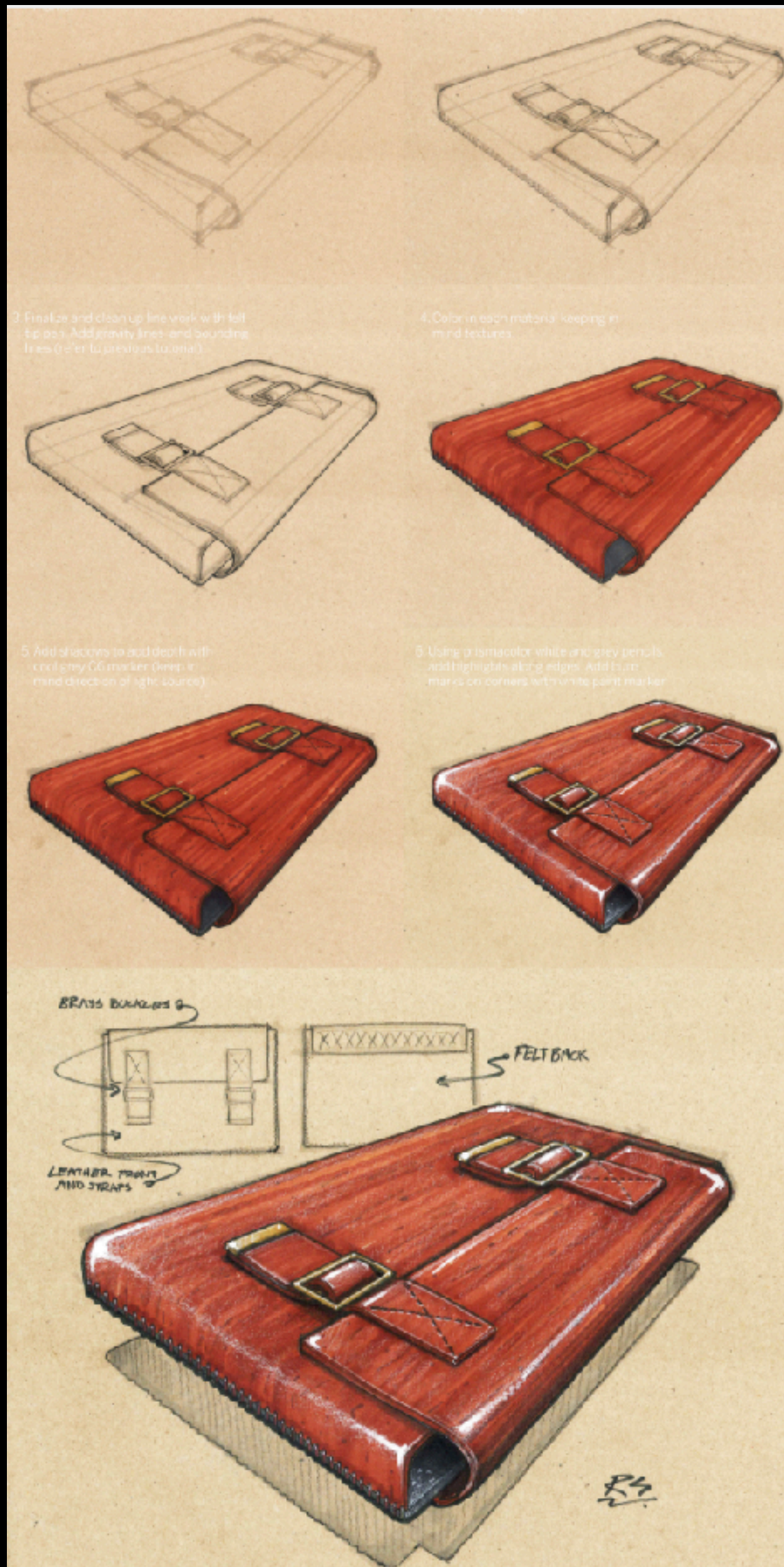

Highlight

The right personal portion and style

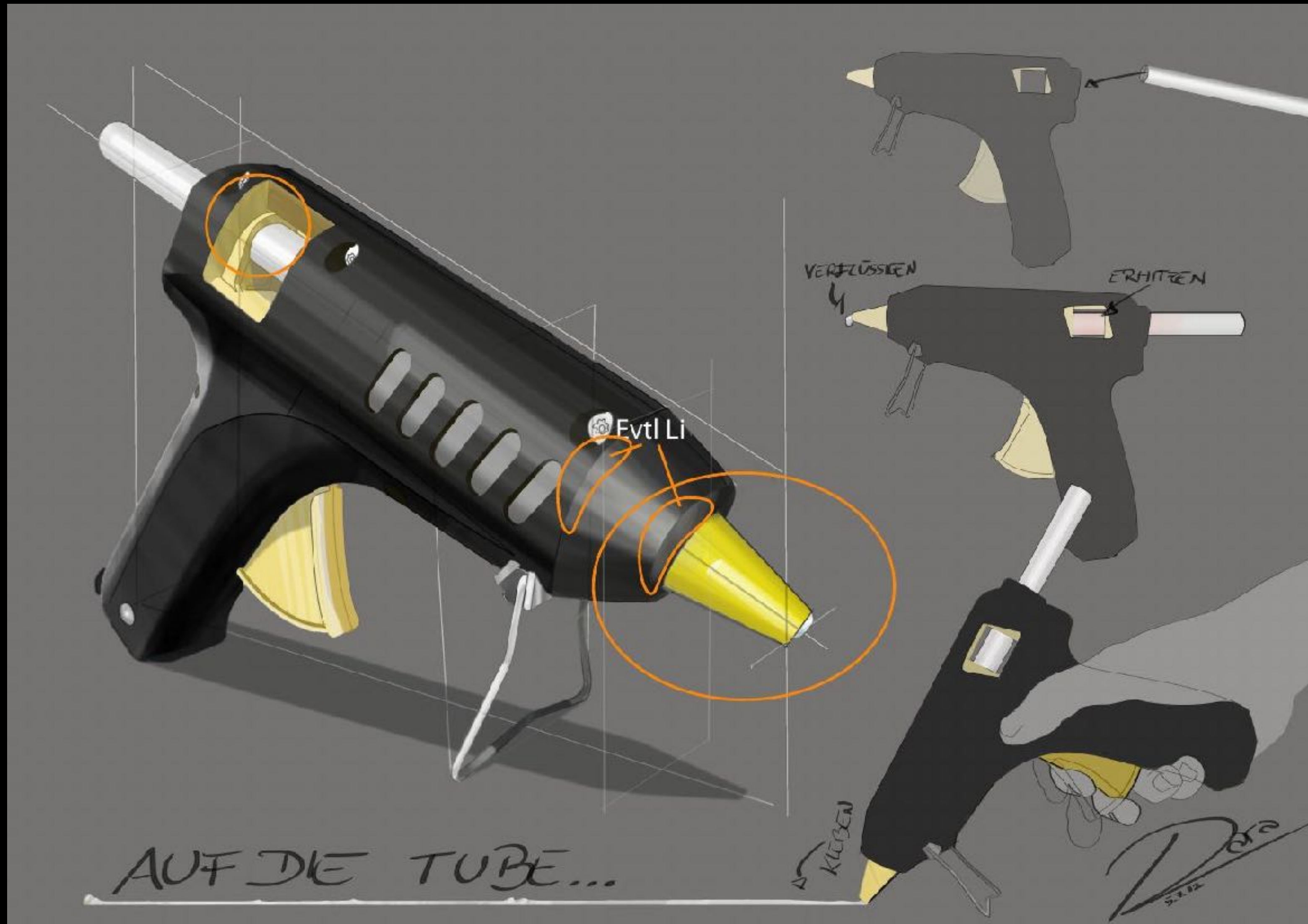

Highlight Color as Expression

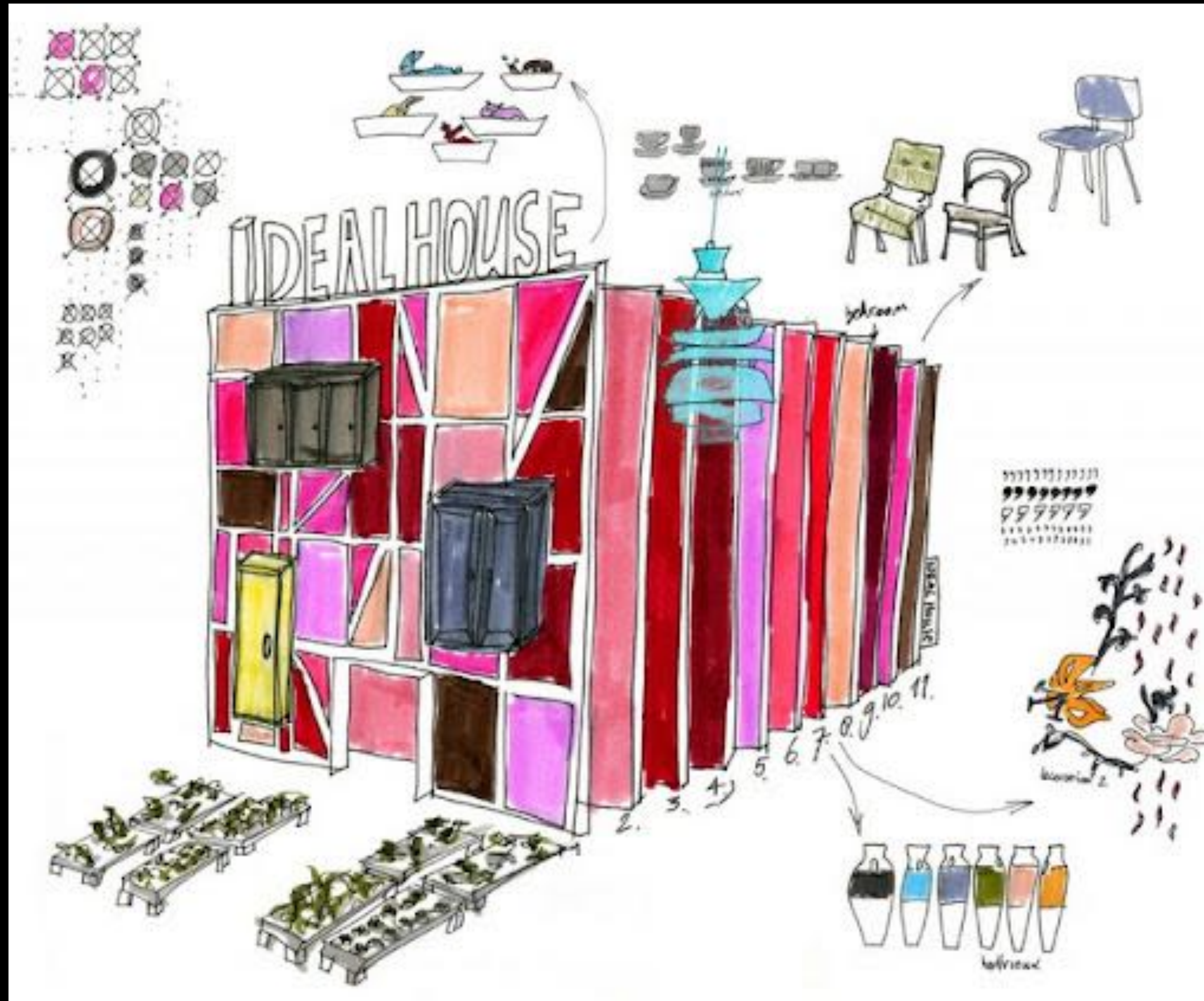

Hella Jongerius,
„Ideal House“, 2005.

Highlight

Color as Shape



Ronan and Erwan
Bouroullec, „Album“,
2013.

Highlight
Color as Shape



Ronan Bouroullec.

Exercise 8

Coloring

Start Coloring a Sketch!

FOR TOMORROW

BRING 1 STRONG PENCIL!

Thank you!

Contact

Rasa Weber | rasa.weber@zhdk.ch

Z

hdk

Zürcher Hochschule der Künste
Bachelor of Arts in Design