

Z

hdk

Zürcher Hochschule der Künste
Bachelor of Arts in Design

Designing Object Experience

Sketching I

Object Experience | 22nd of September 2021

lecturer
Rasa Weber

Overview

Today's Schedule

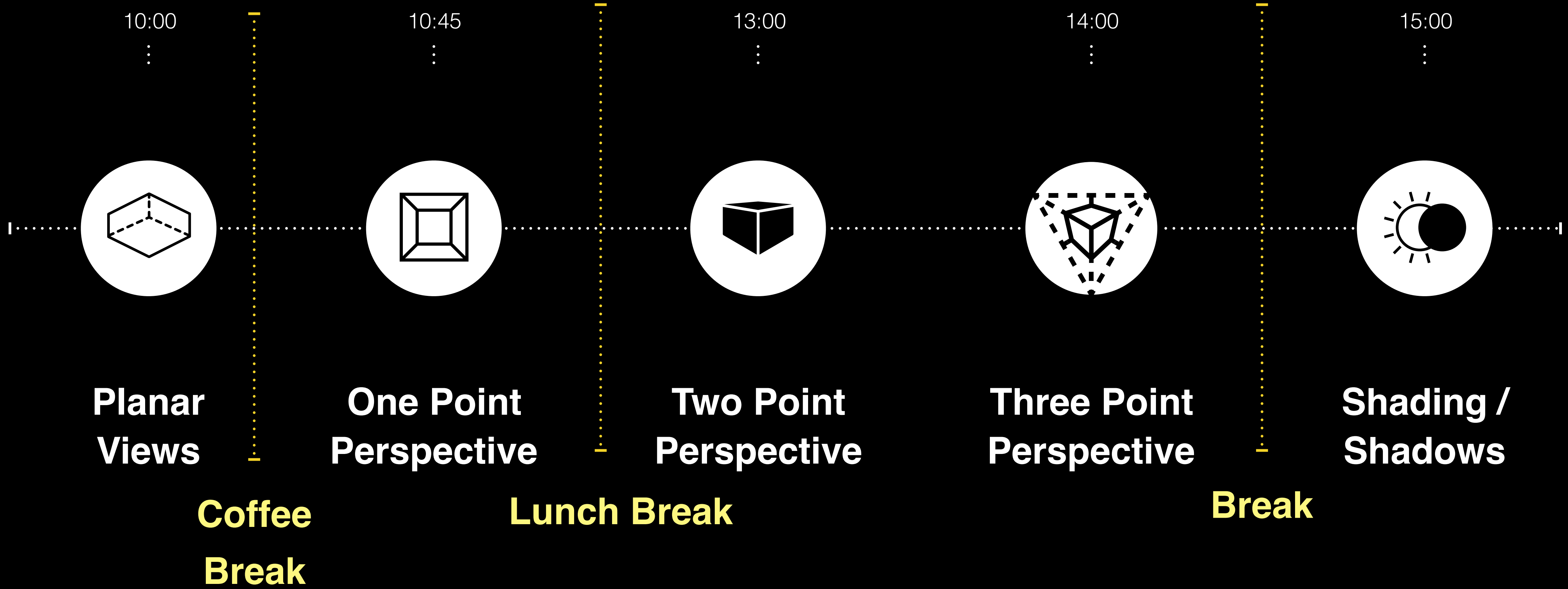

**WHAT IS A GOOD
SKETCH FOR YOU?**

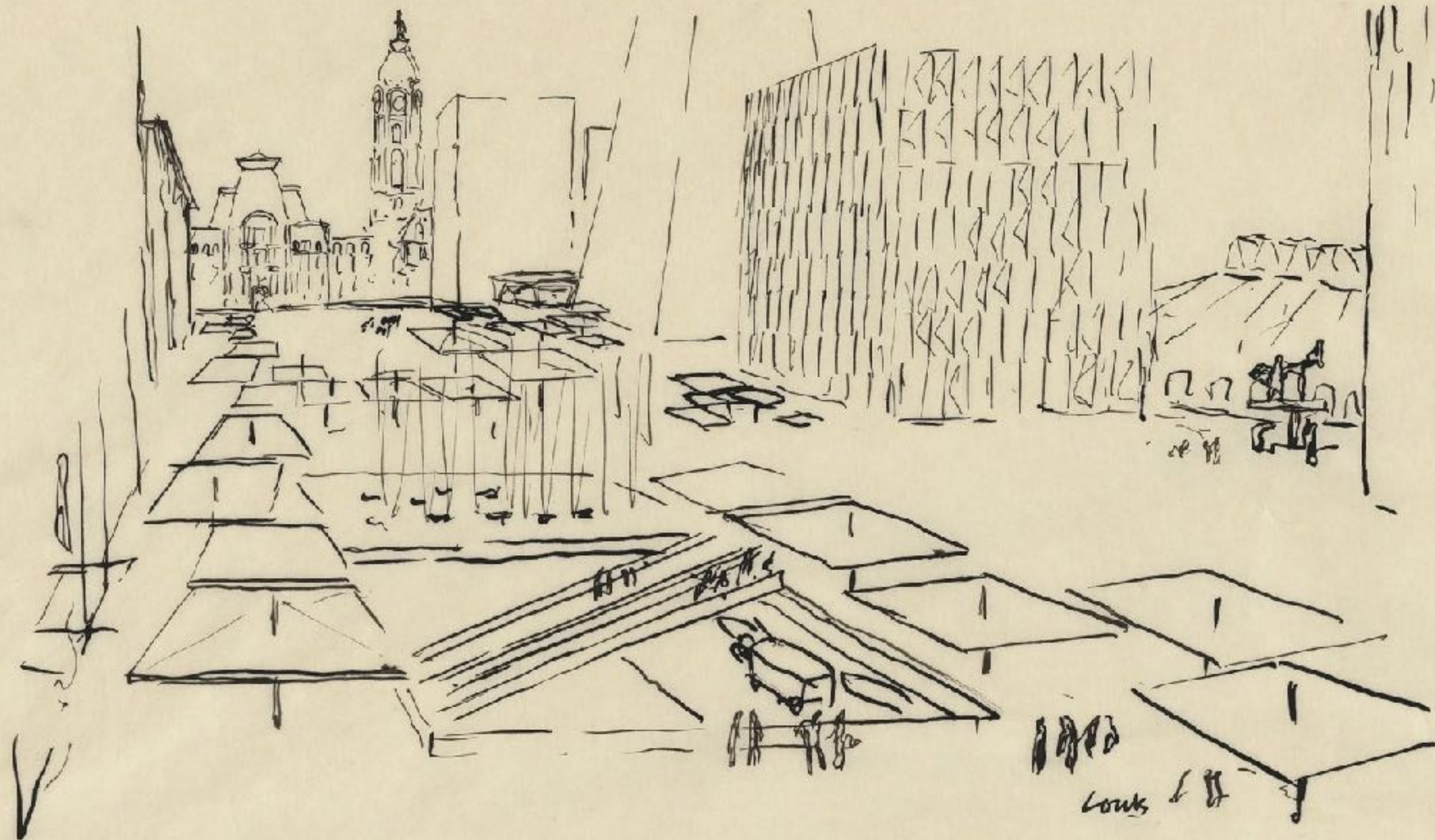

Louis Kahn, 1901–1974, Sketch MOMA

There is no value in trying to imitate exactly. Photographs will serve you the best of all, if that's your aim. We should not imitate when your intention is to create – to improvise.... I try in all my sketching not to be entirely subservient to my subject, but I have respect for it, and regard it as something tangible – alive – from which to extract my feelings.

Louis I. Kahn, “The Value and Aim in Sketching”

SKETCHING

THE BEGINNING

Sketching Practice

The first stroke - the fear of starting

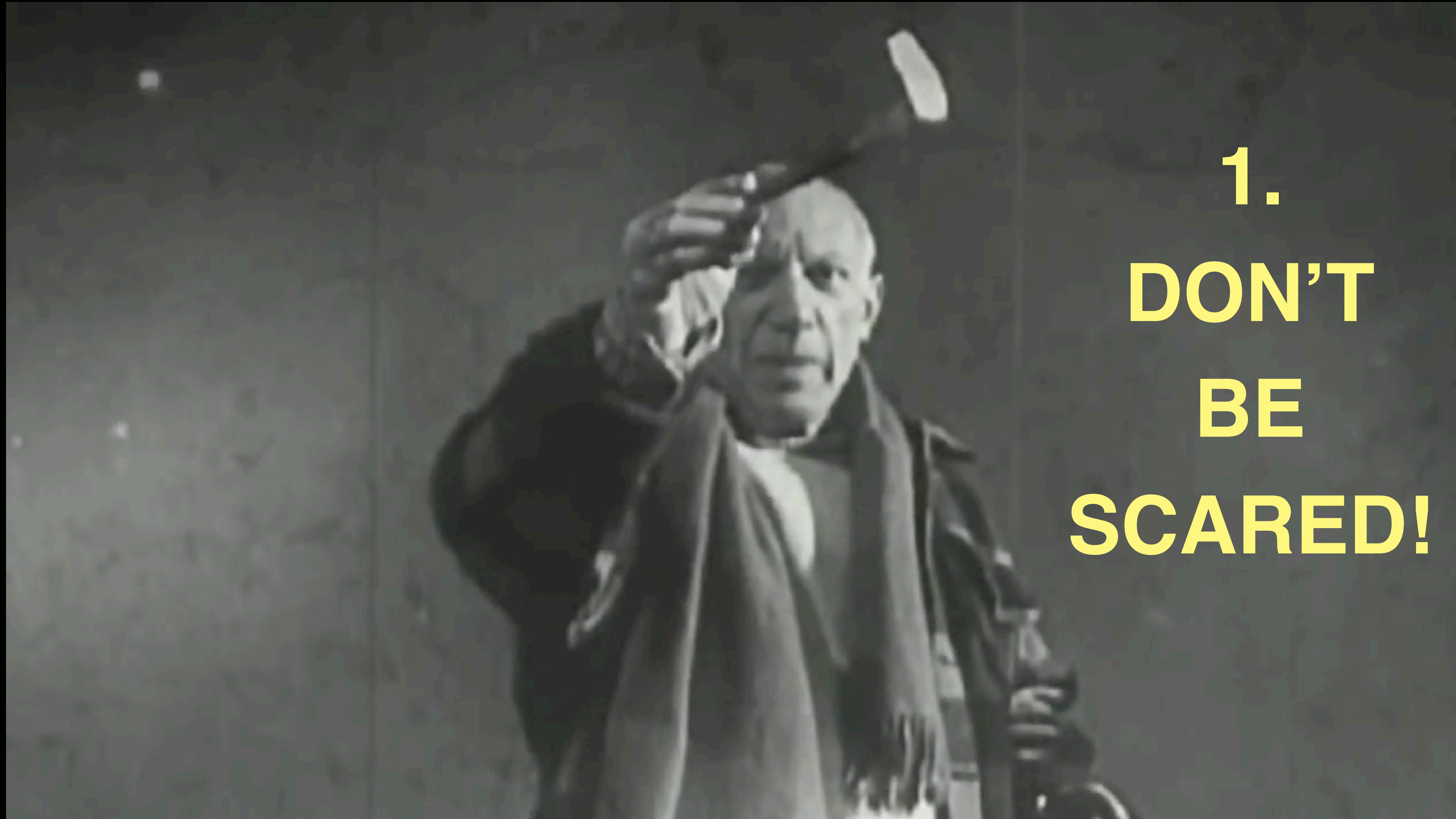

Film by: Scene from 'Visit to Picasso', by Paul Haesaert, 1949.

Sketching Practice

The first stroke - the fear of starting



2.
DON'T
BE
SCARED!

Sketching Practice

Dreaming - First ideas

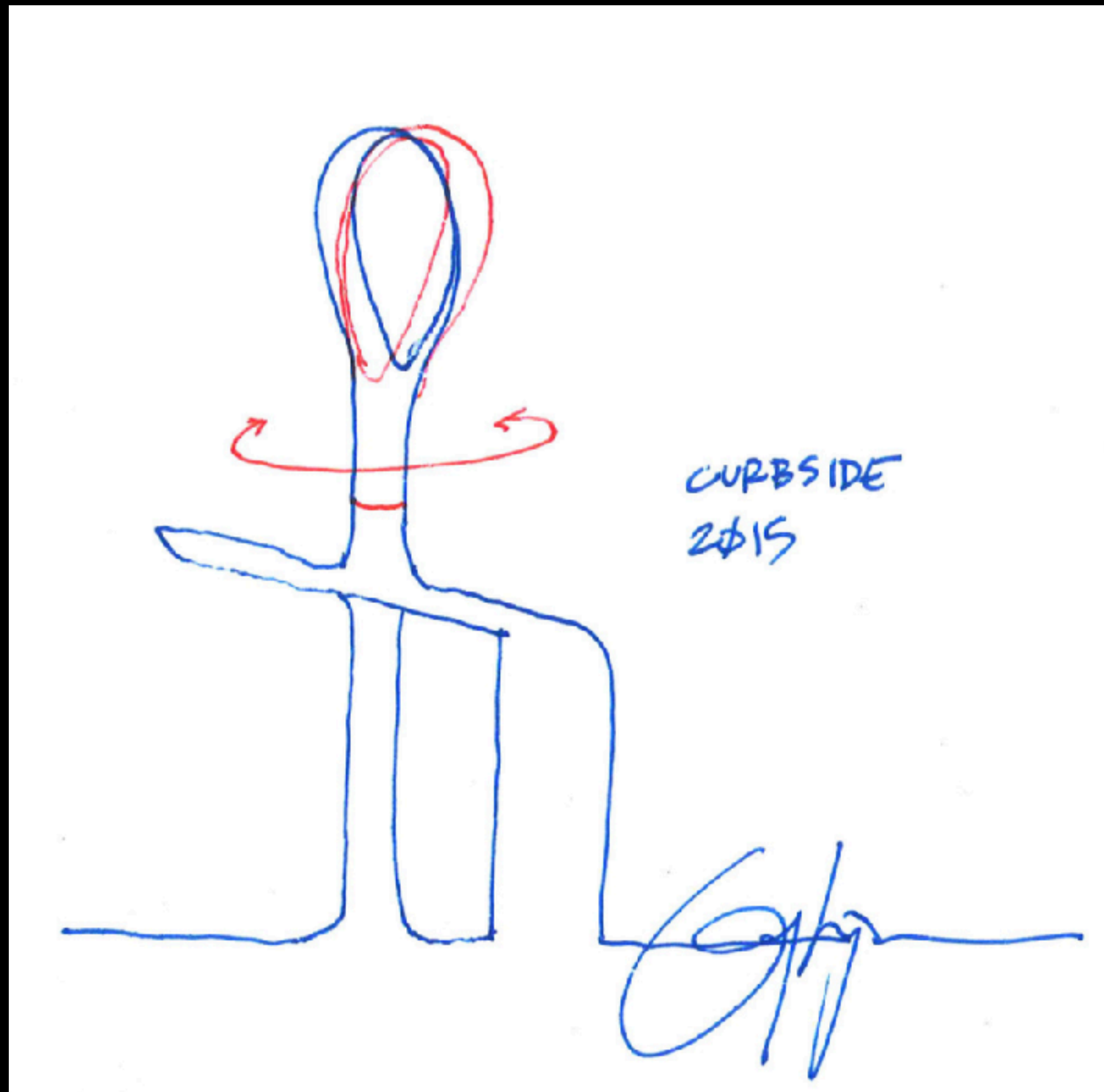

Sketch by: Greg Lynn on Napkin



Sketch by: Frank Gehry, Guggenheim Bilbao, 1993

Sketching Practice

Sketching and Perception

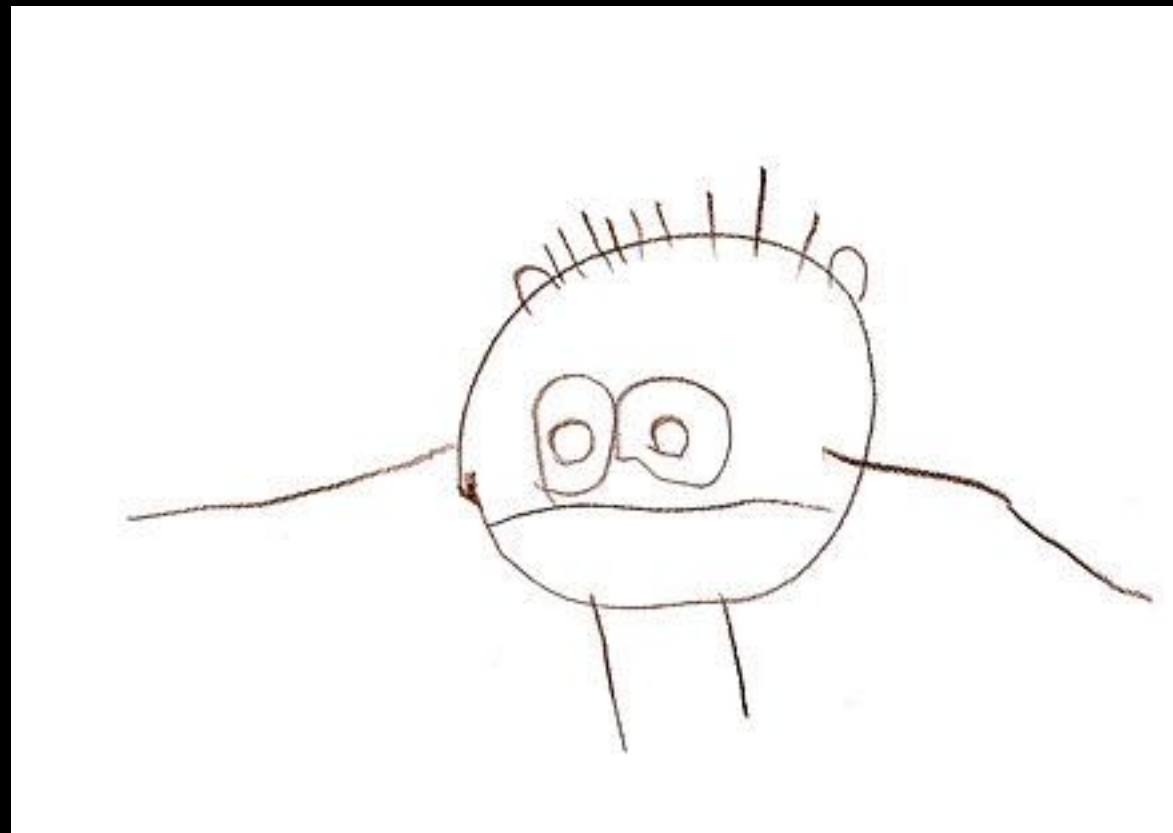

Child Sketch "Kopffüßler"



Child Sketch "Vorschemaphase"



Child Sketch "Werkreife"

Sketching Practice

Sketching and Perception

3.

SKETCH WHAT YOU SEE!

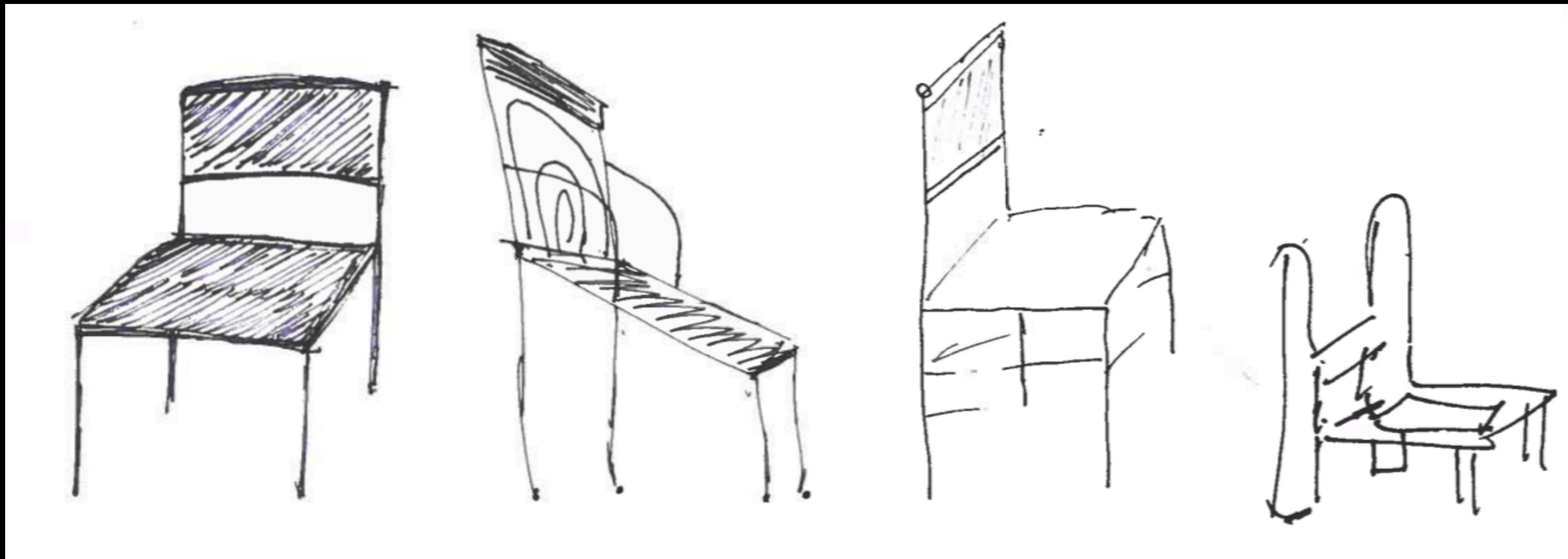

Drawing of chairs by non-designers of different age and gender

Sketching Practice
Generate variations



Sketches by Robert Bronwasser, SMOOL

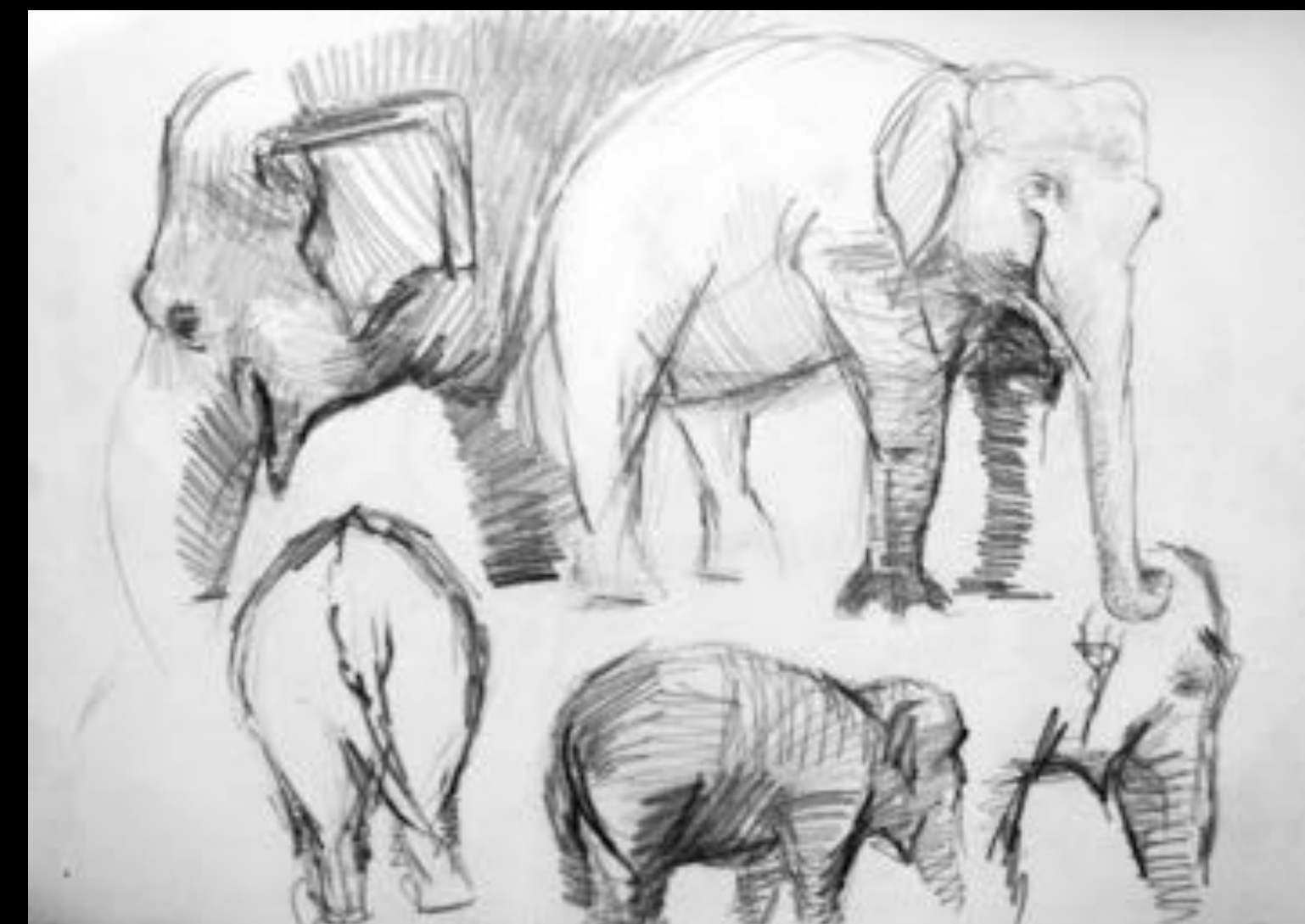

4.
NEVER
EVER
STOP!

Sketching Practice

The development

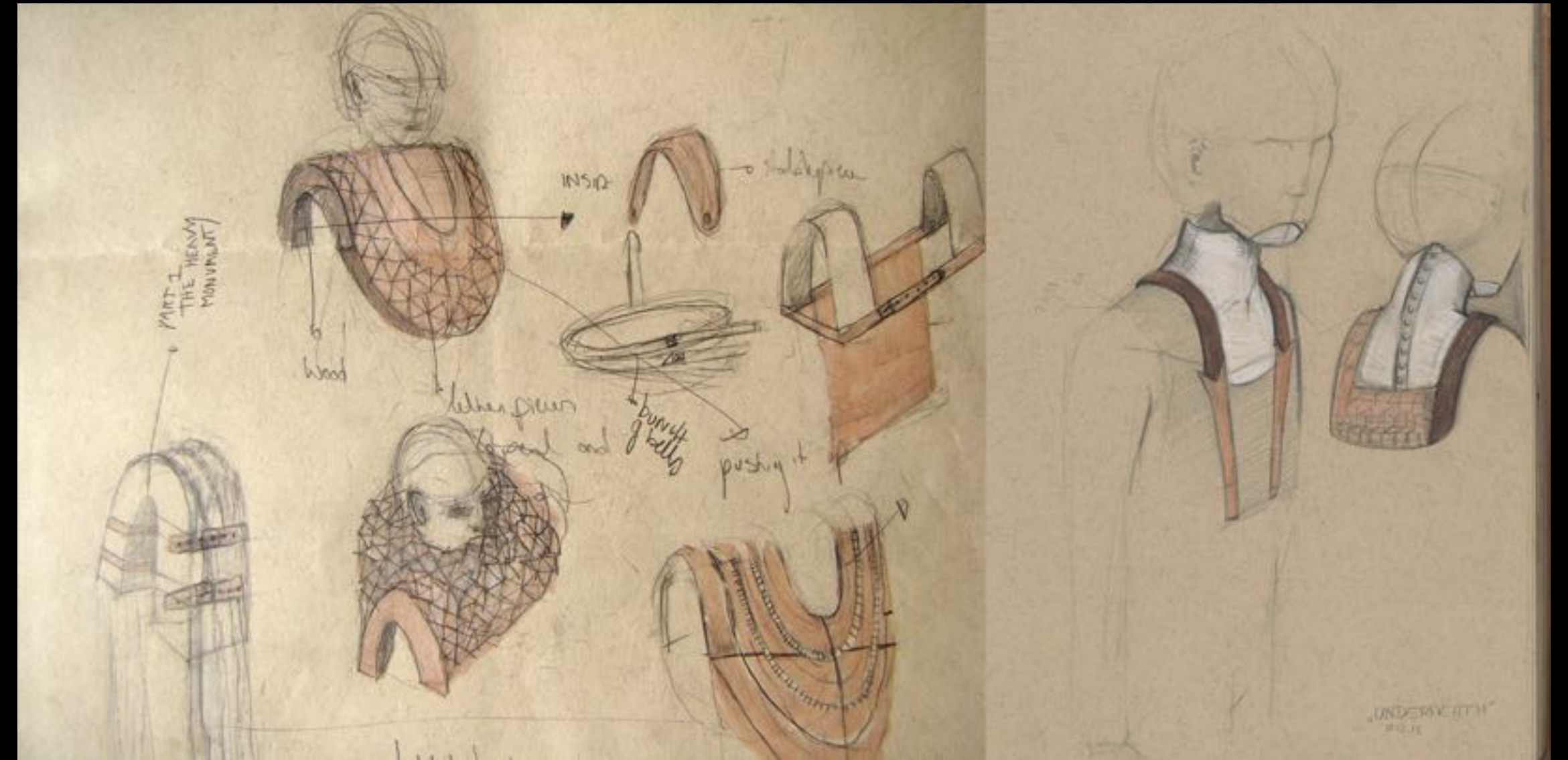

SKETCHING

THE BASICS

THE BASICS

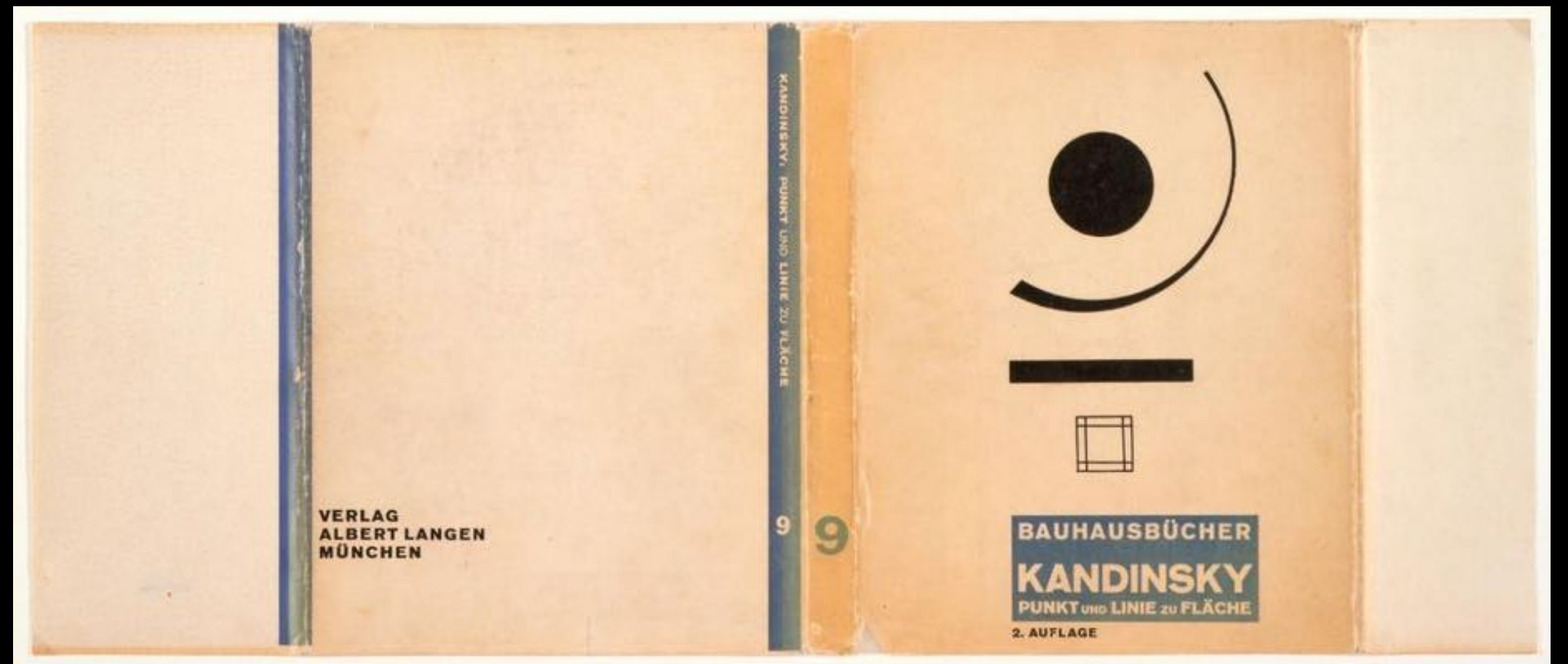
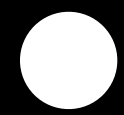

Bauhausbücher – Band 9. Punkt und Linie zu Fläche, Umschlaggestaltung: László Moholy-Nagy, 1926/28.

Sketching Form Space

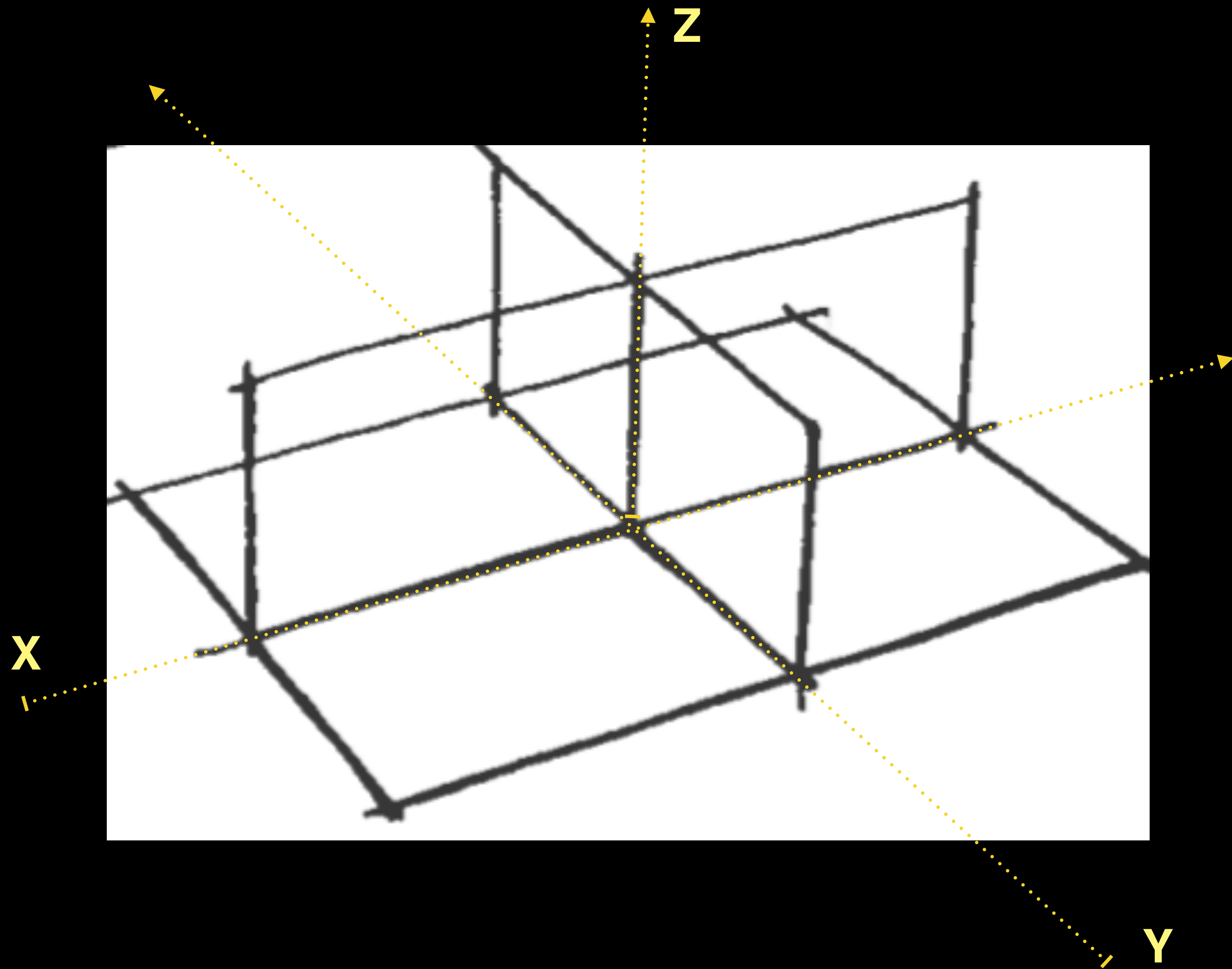

Sketching Form

HOW TO DO A STROKE?



Sketching Form

HOW TO ORGANIZE A PAPER ?

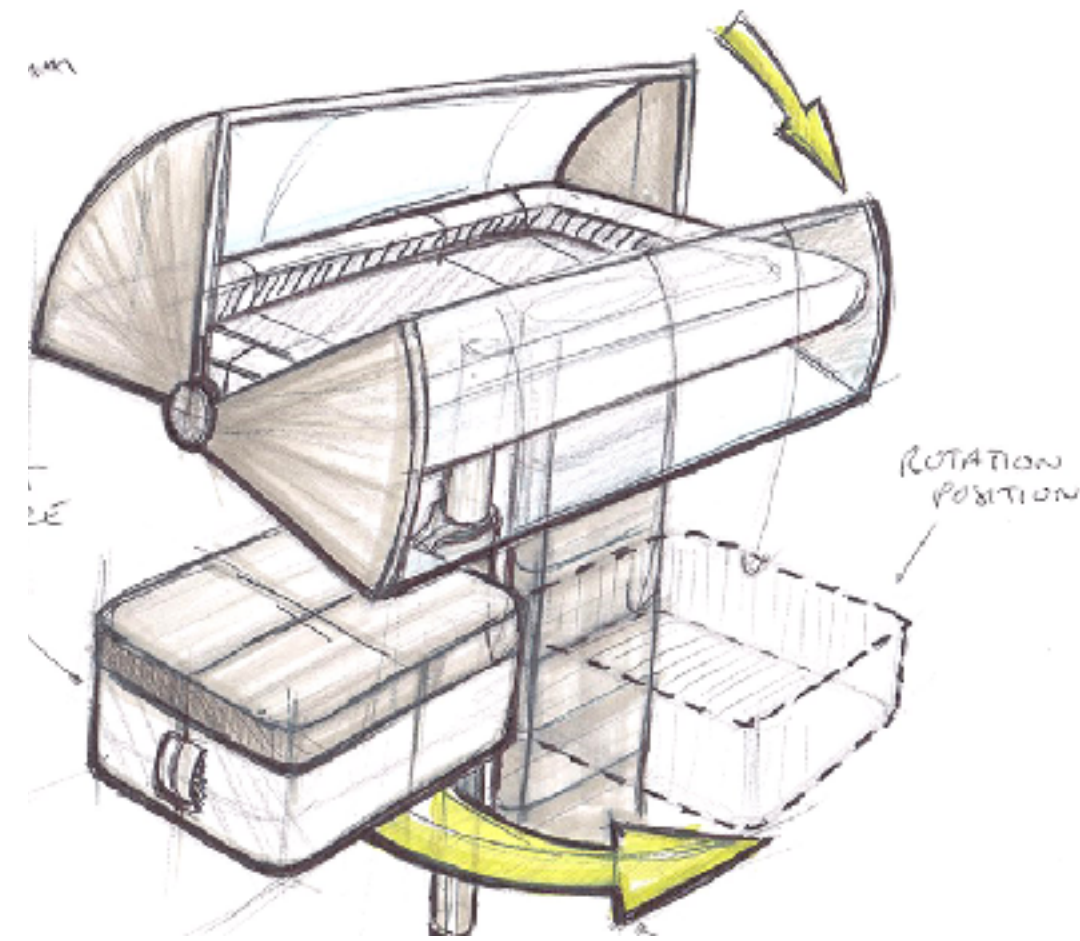

Sketching Form

HOW TO ORGANIZE A PAPER ?

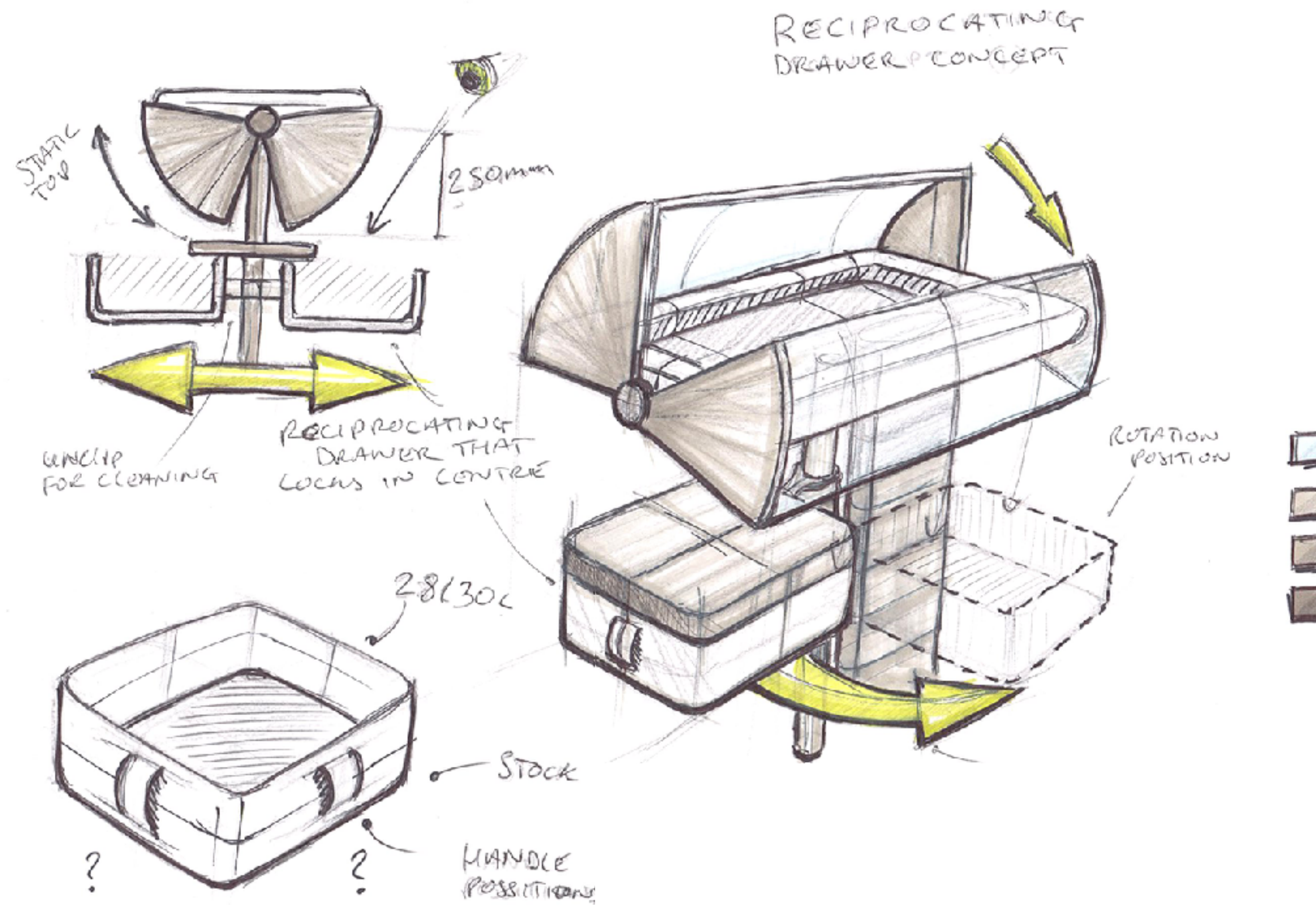

Sketching Form

HOW TO ORGANIZE A PAPER ?

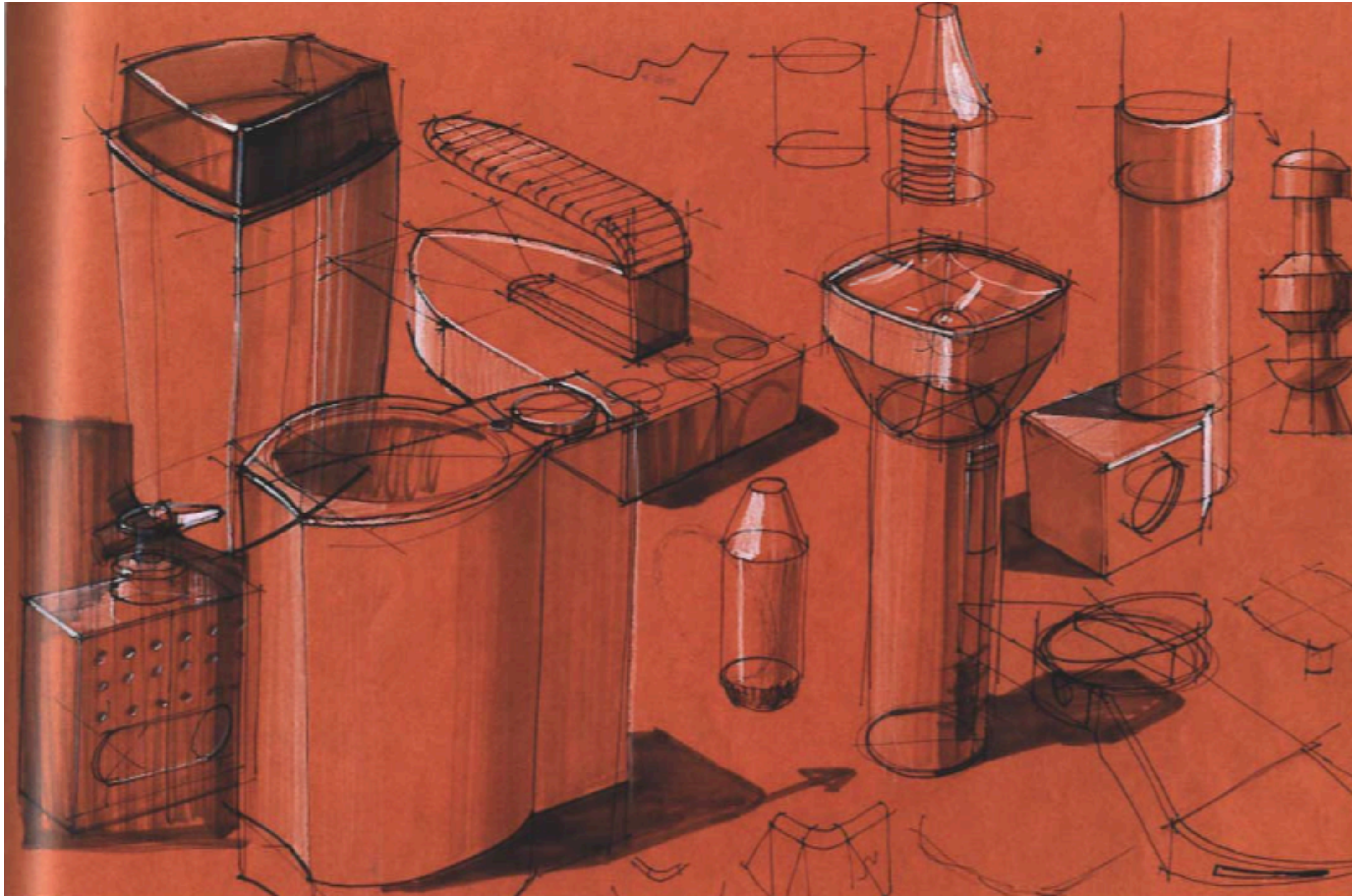

Sketching Form

WHAT IS IMPORTANT?

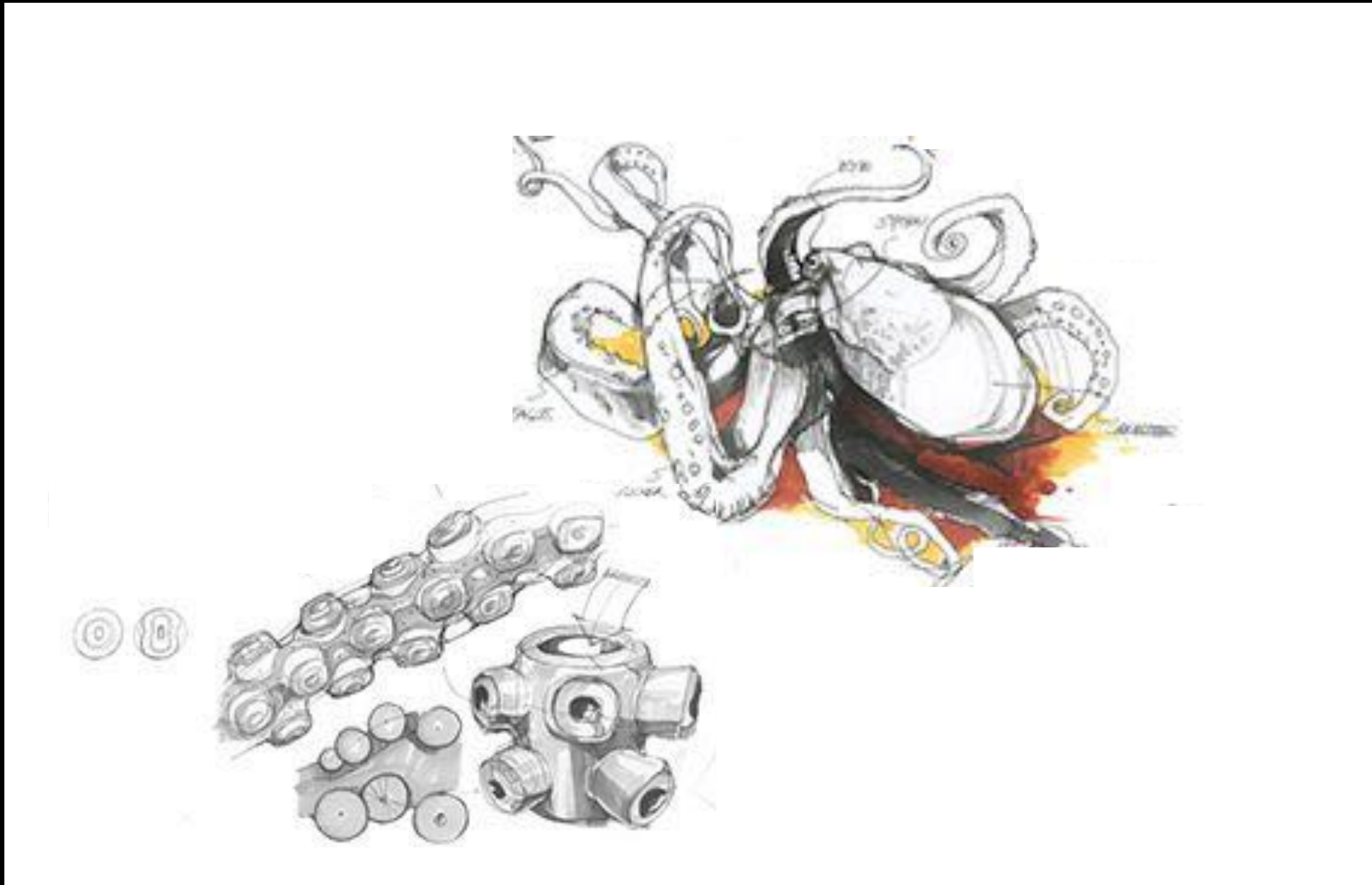

Sketching Form

WHAT IS IMPORTANT?

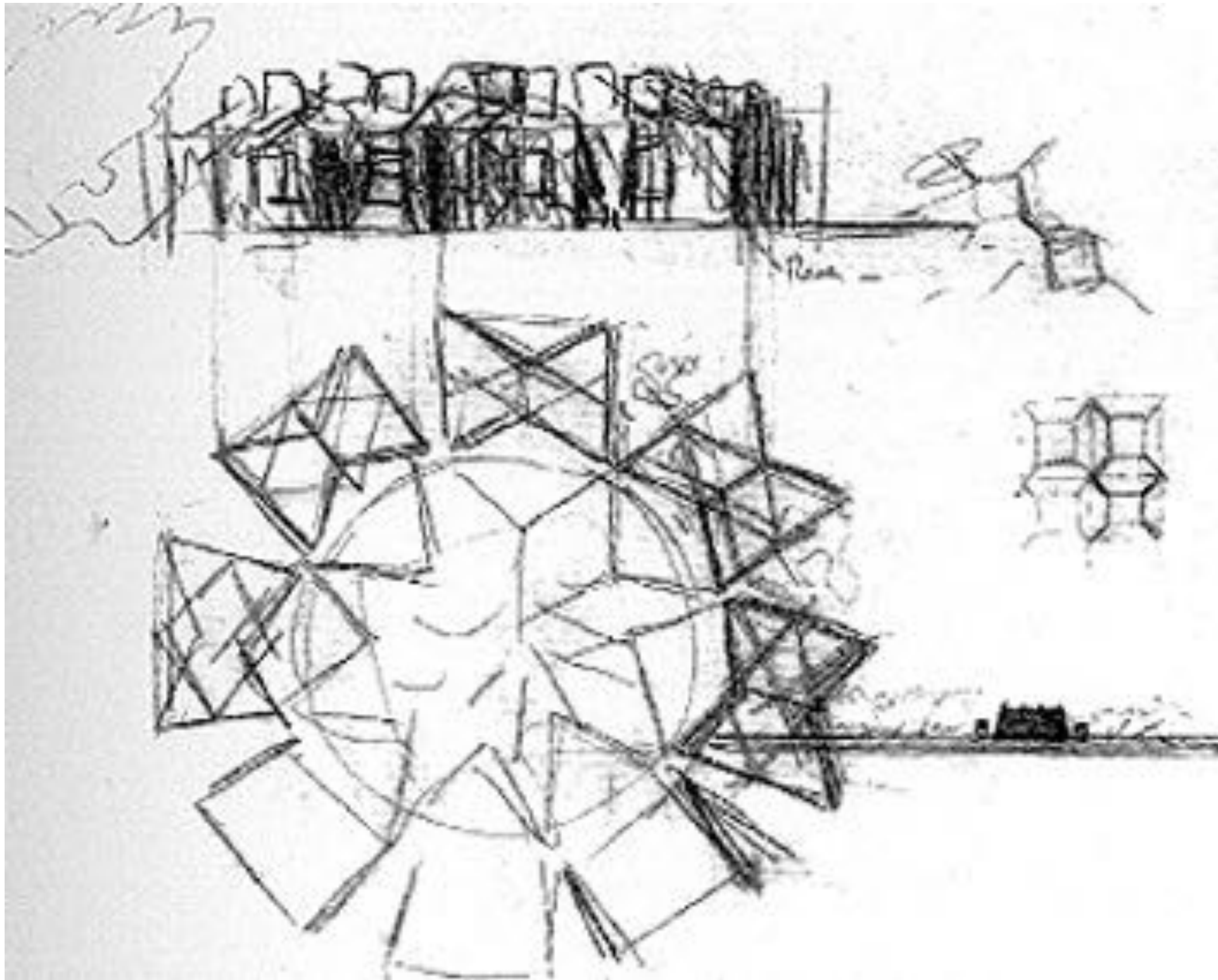

Sketching Form

WHERE DOES THE LIGHT COME FROM?

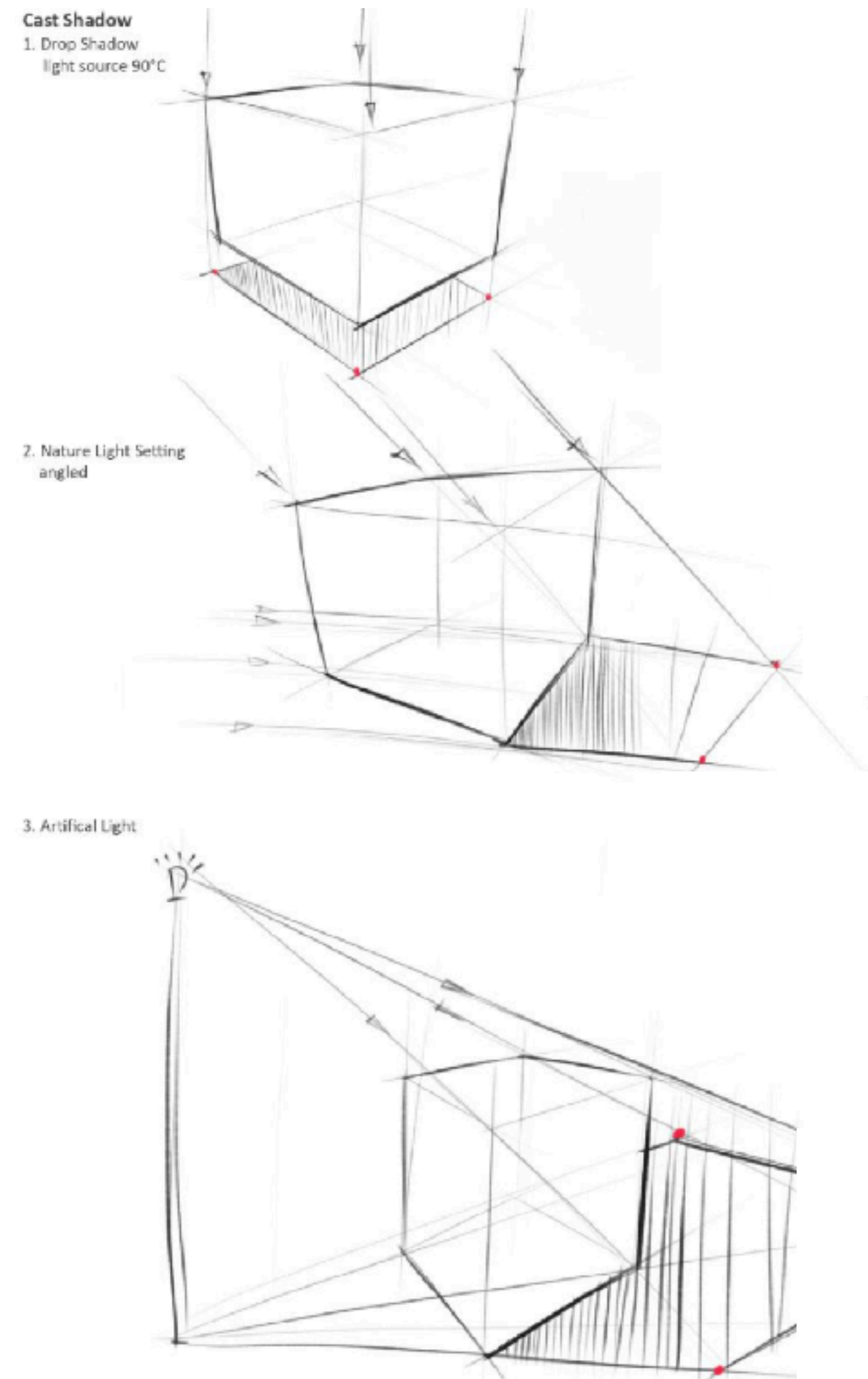

Sketching Form

WHEN IS THE BEST POINT TO STOP?



Louis I. Kahn, Travel **Sketch** for Sainte Cécile Cathedral, 1959.

Sketching Form

WHEN IS THE BEST POINT TO STOP?



Hugo Barros Costa.

Sketching Form

HOW TO ORGANIZE THE OBJECT?

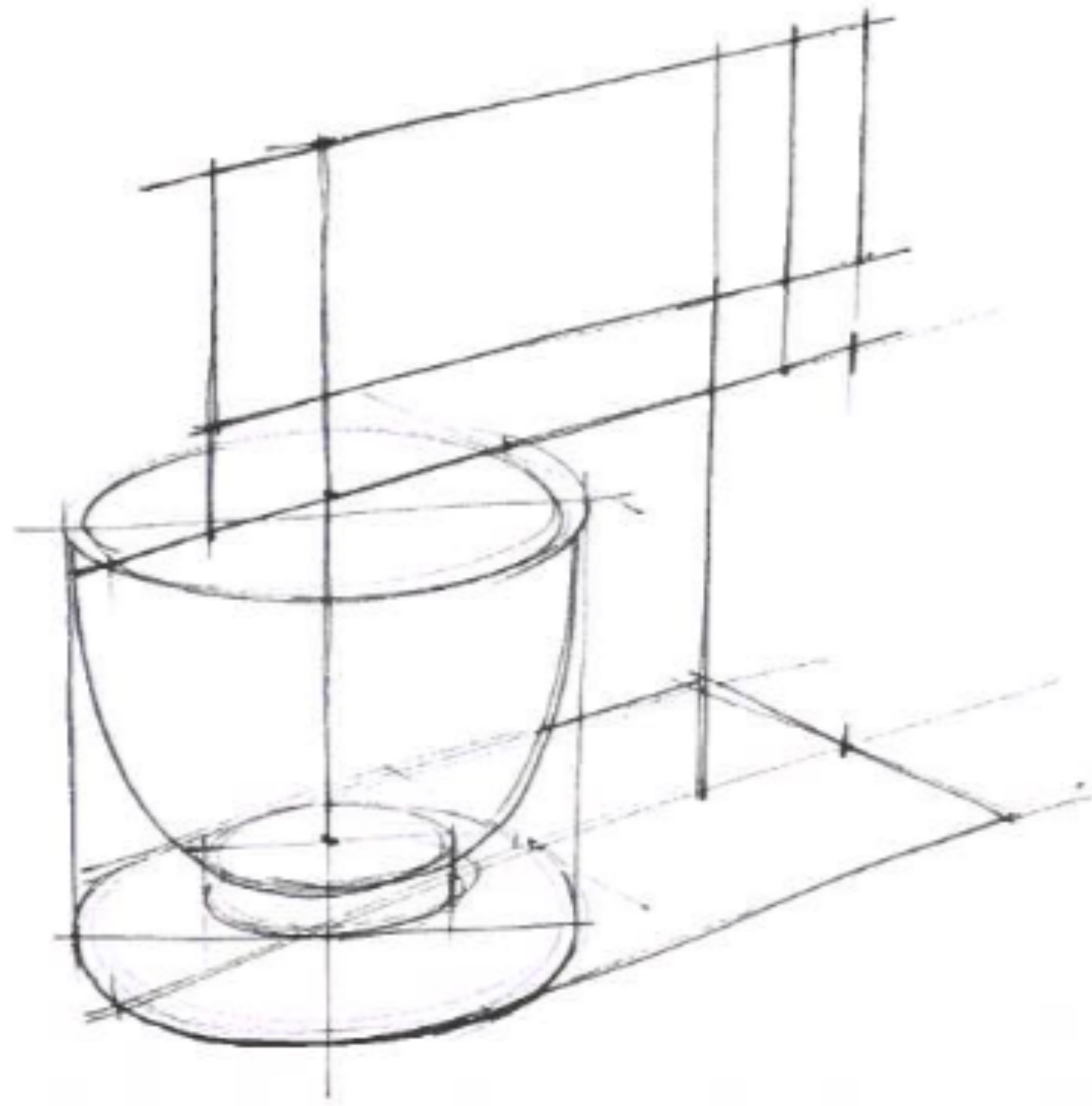

Exercise 1

1 MINUTE SKETCHES

15 min

Sketching Form

SIDE VIEW AND TOP

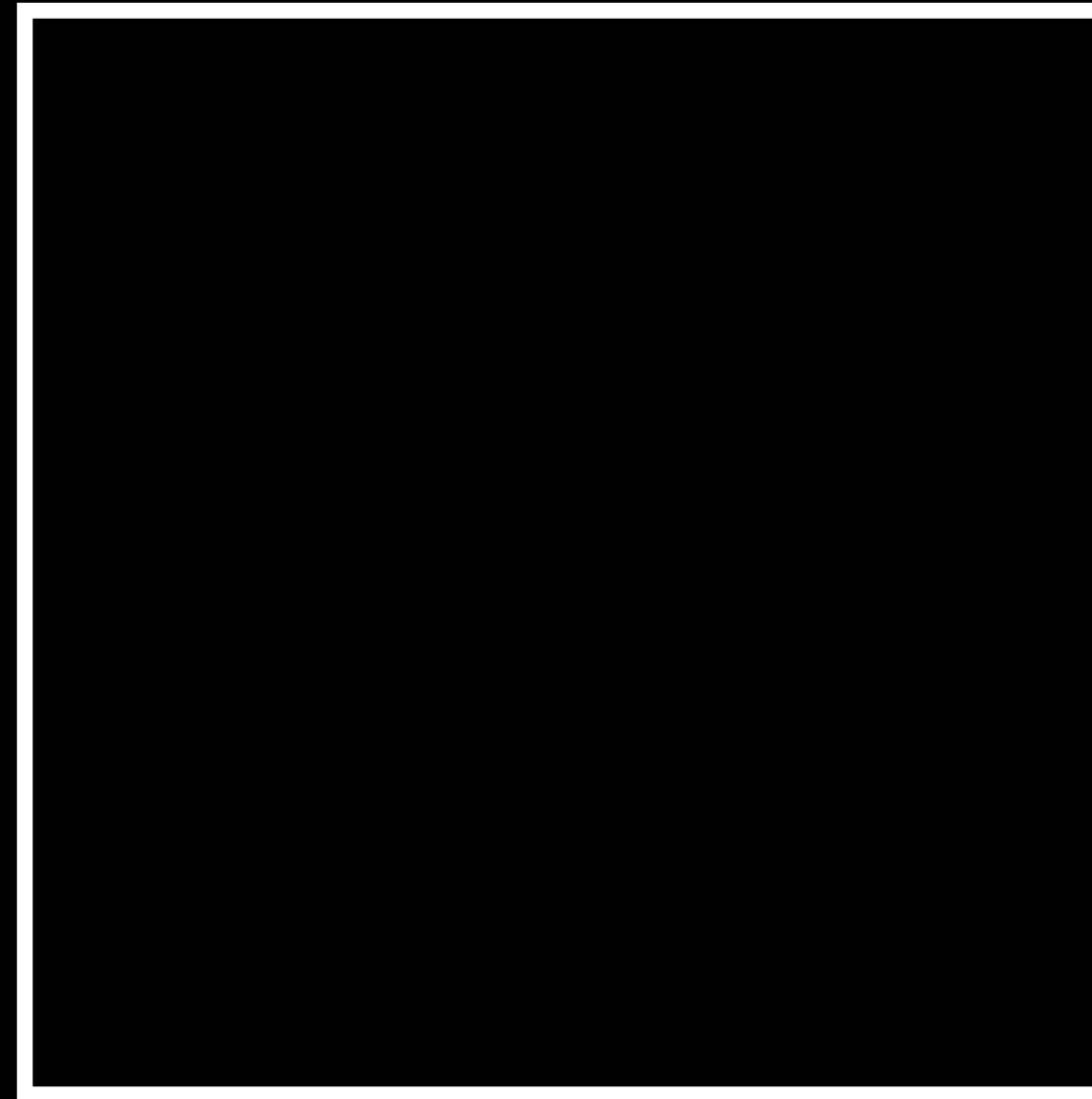

Sketching Form

Planar Views

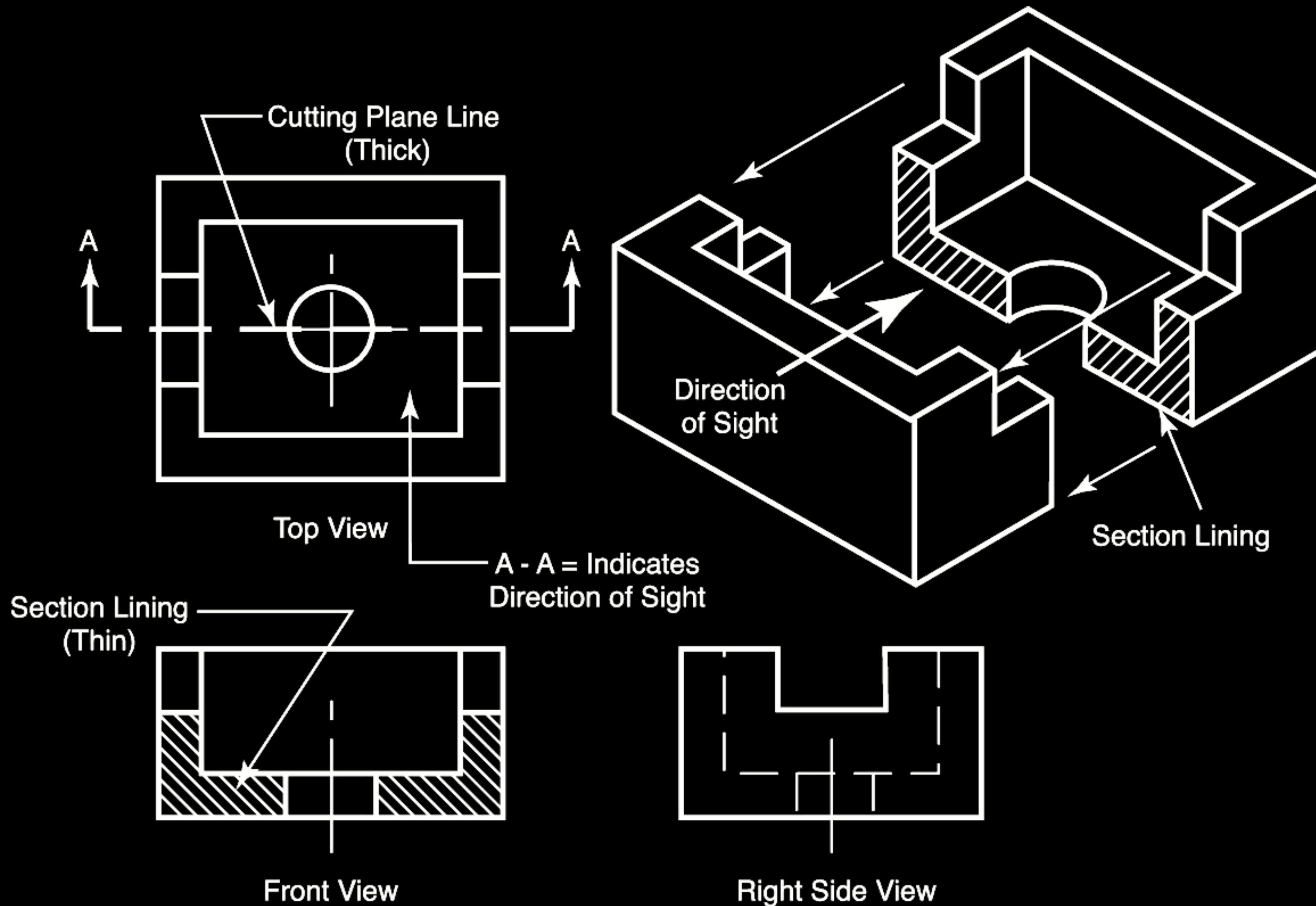

Sketching Form

Planar Views

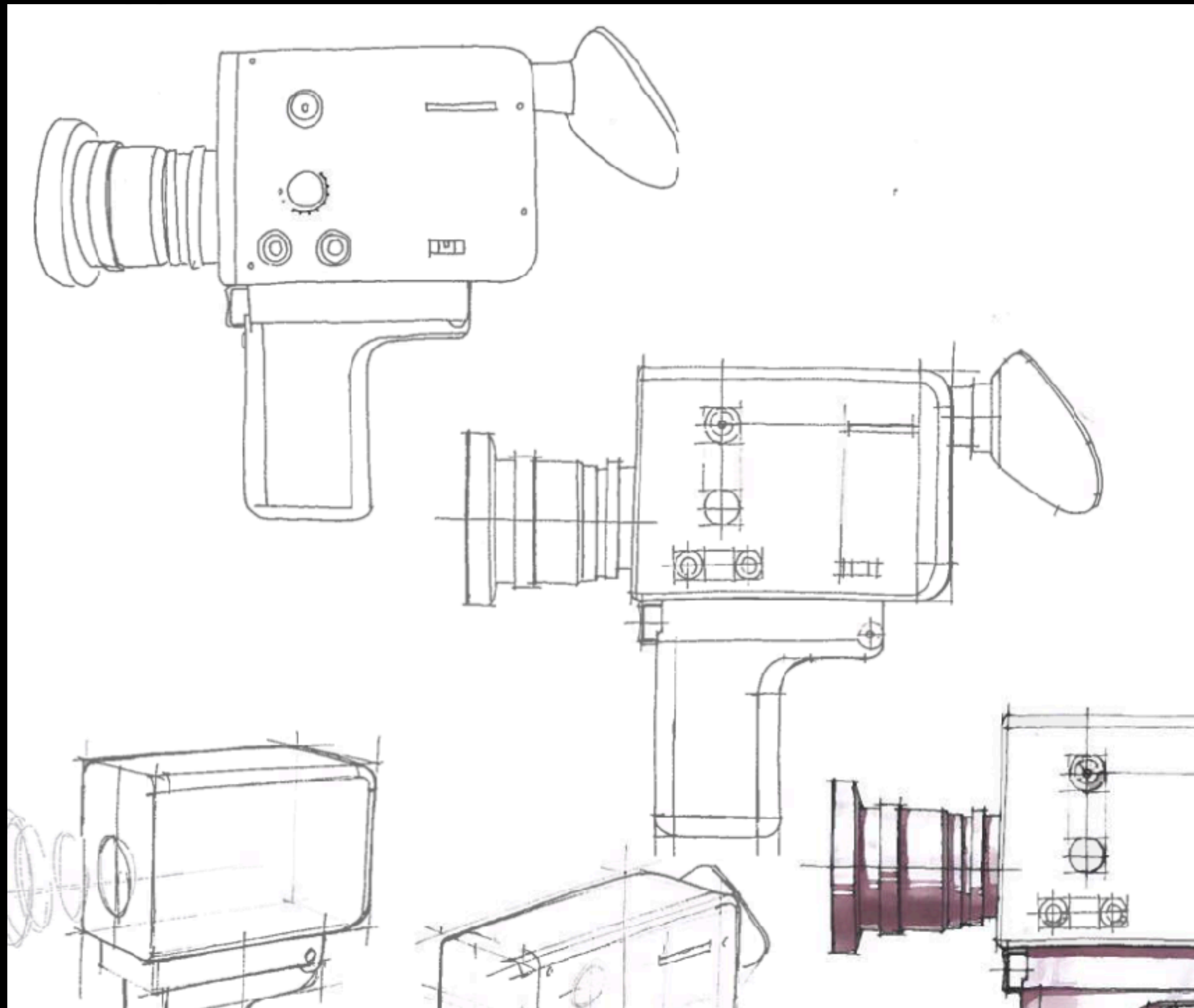

Sketching the Basics
Steur, Eissen
2011

Sketching Form

SIDE VIEW & TOP VIEW

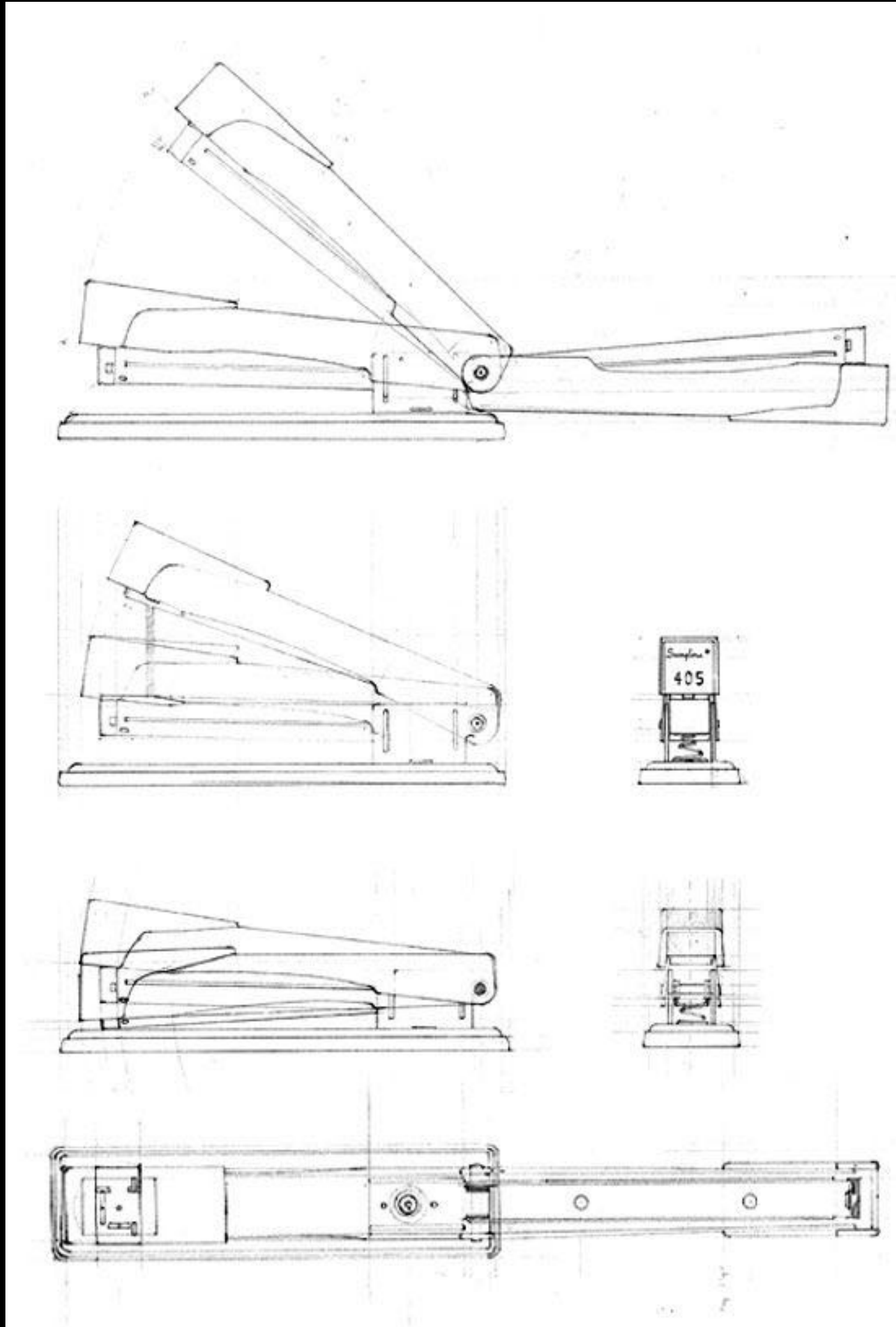

Sketching Form

SIDE VIEW & TOP VIEW

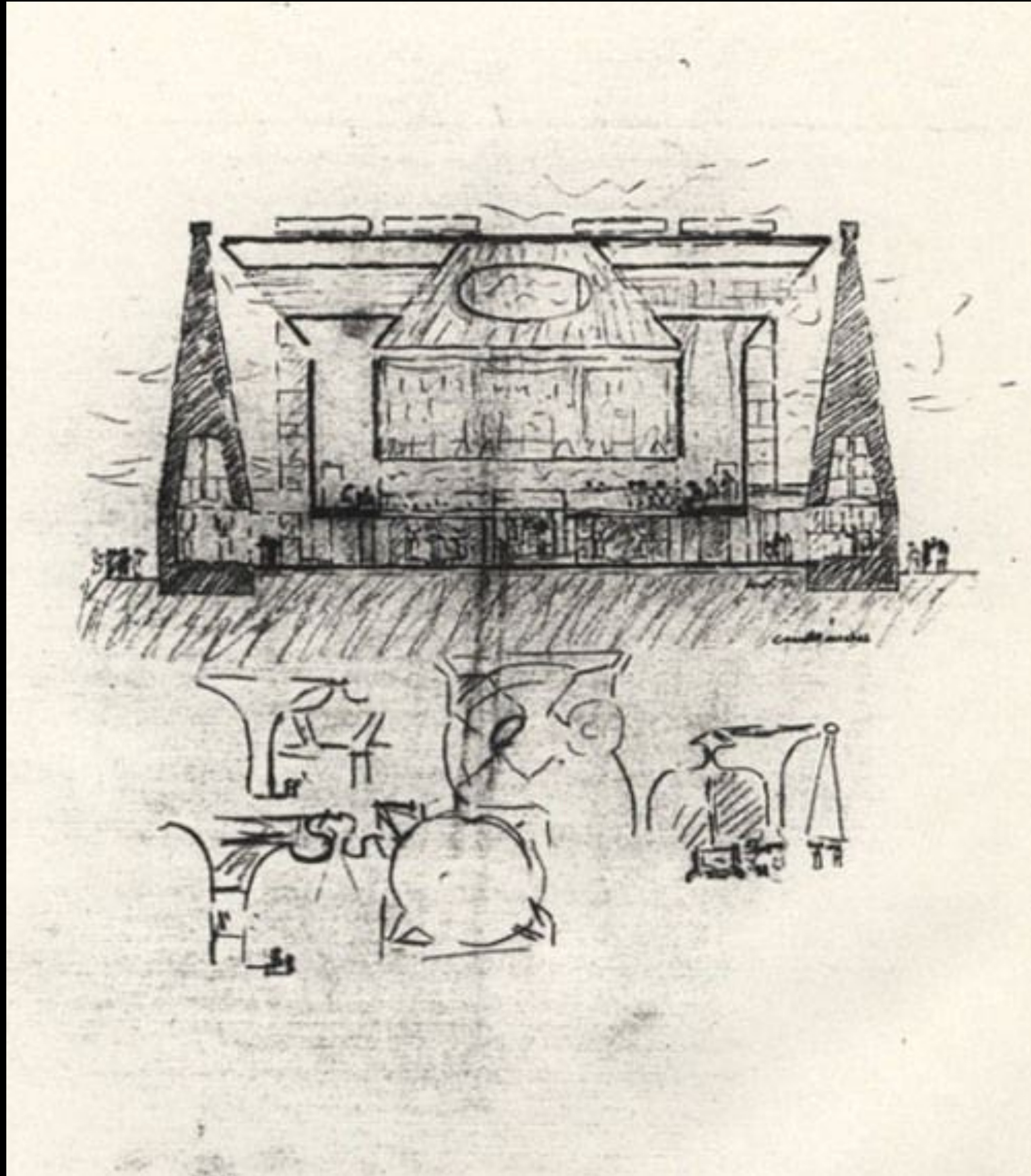

Exercise 2

SIDE VIEW OF YOUR OBJECT

15 min

Sketching Form

AXONOMETRIC DRAWING

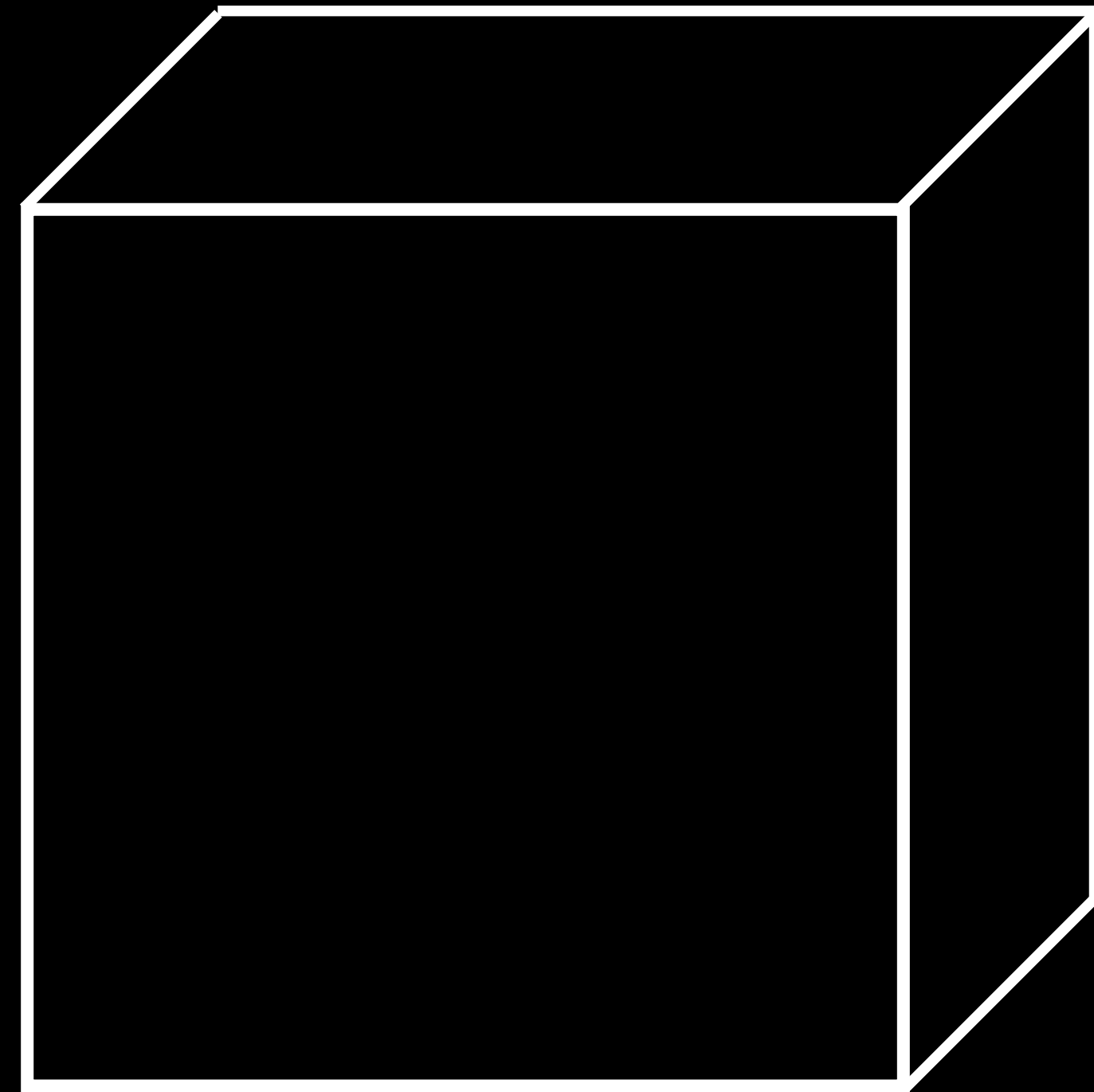

Sketching Form

WHAT IS AN AXONOMETRIC DRAWING?

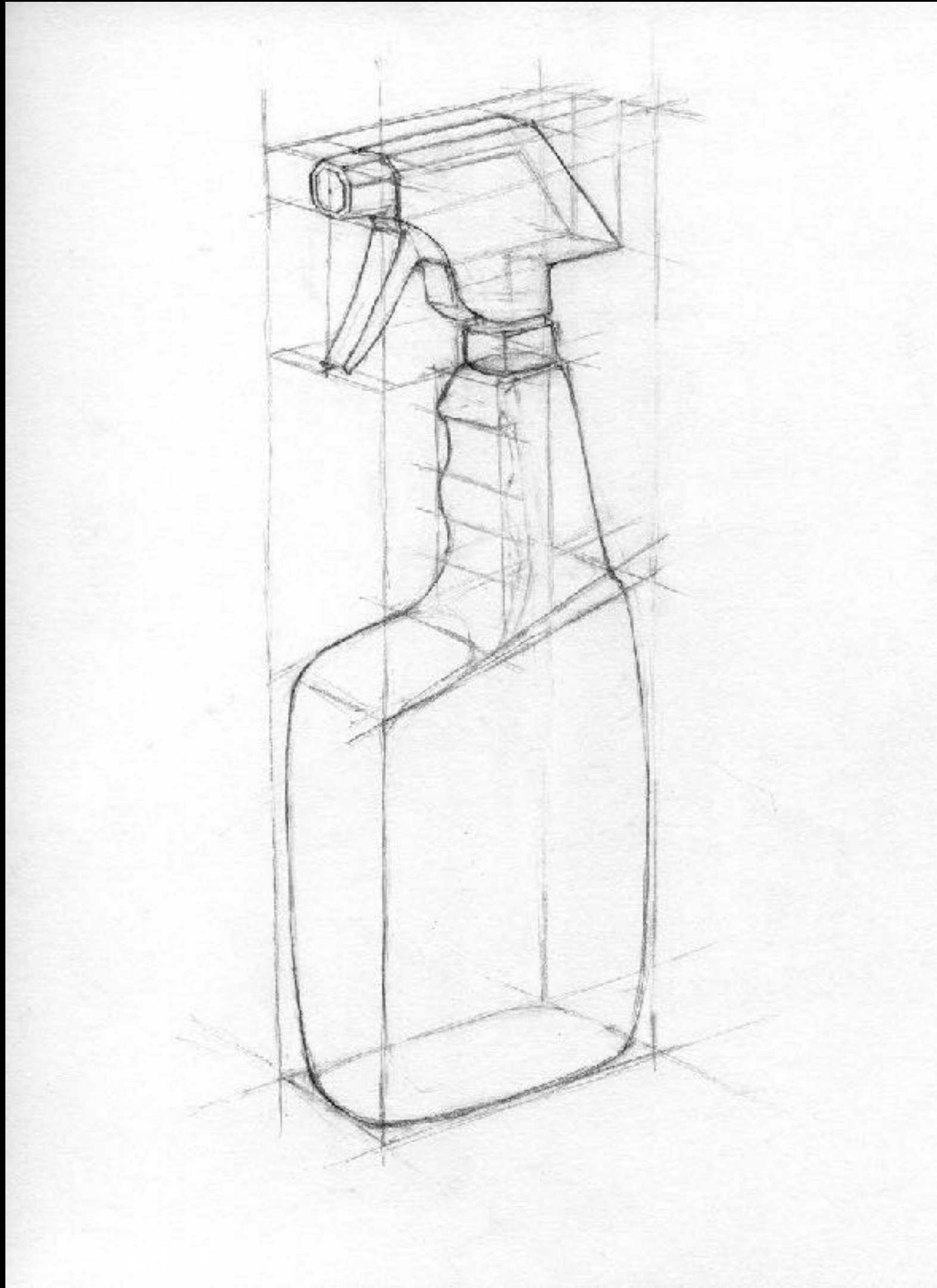

Sketching Form

WHAT IS AN AXONOMETRIC DRAWING?

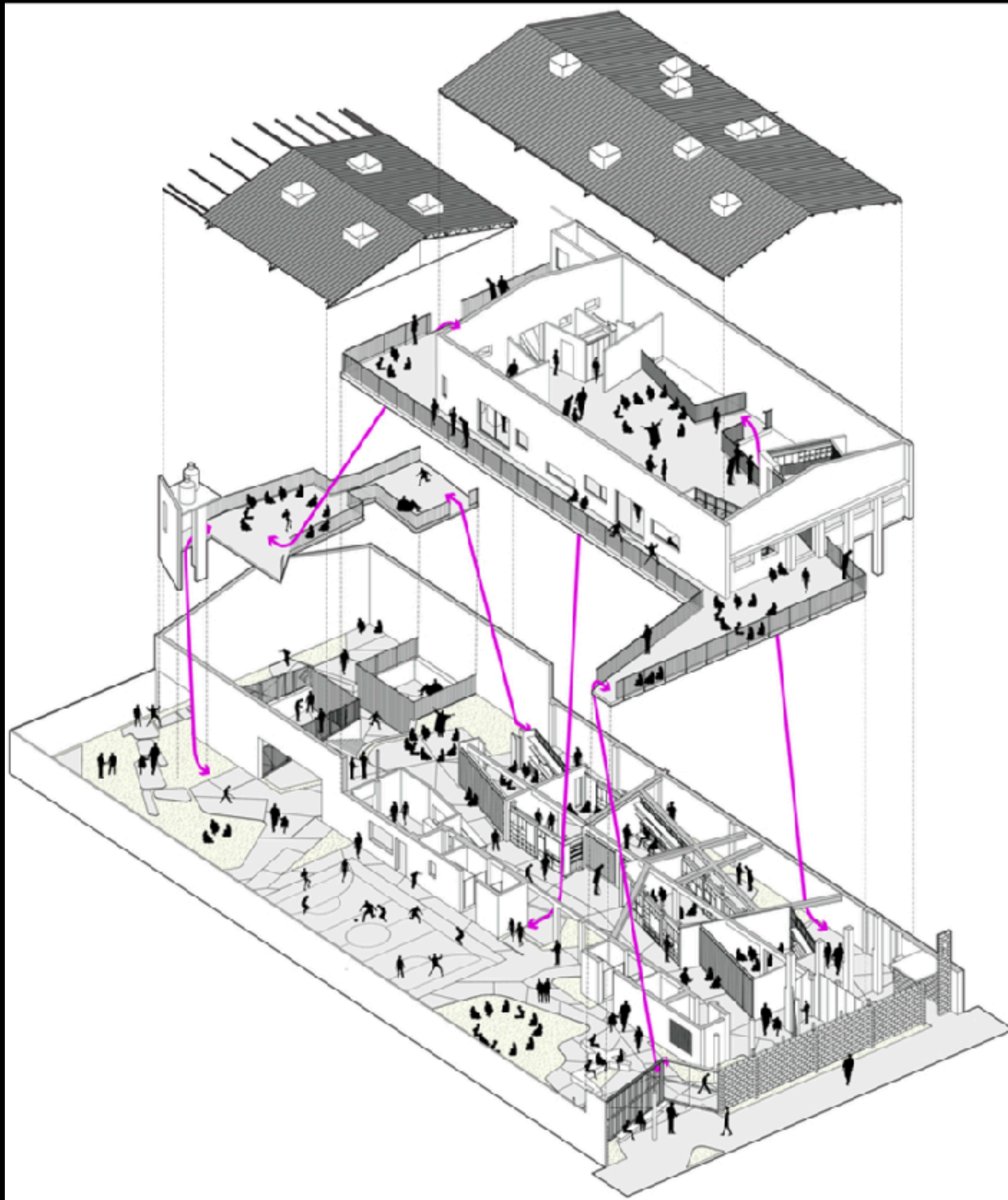

Exercise 3

AXONOMETRIC DRAWING

5 min

COFFEE BREAK

Sketching Form

1 Point Perspective

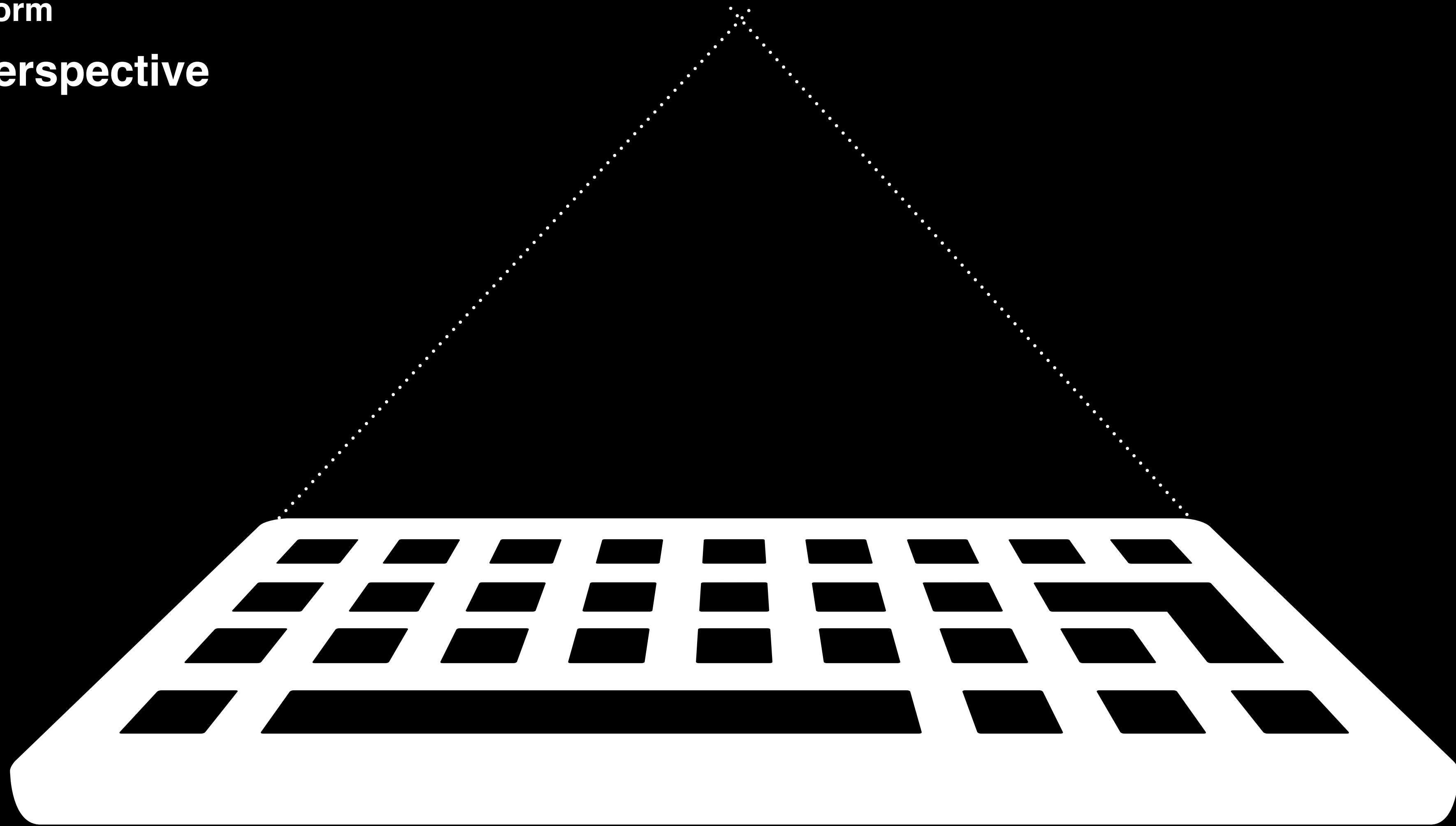

Sketching Form

1 Point Perspective

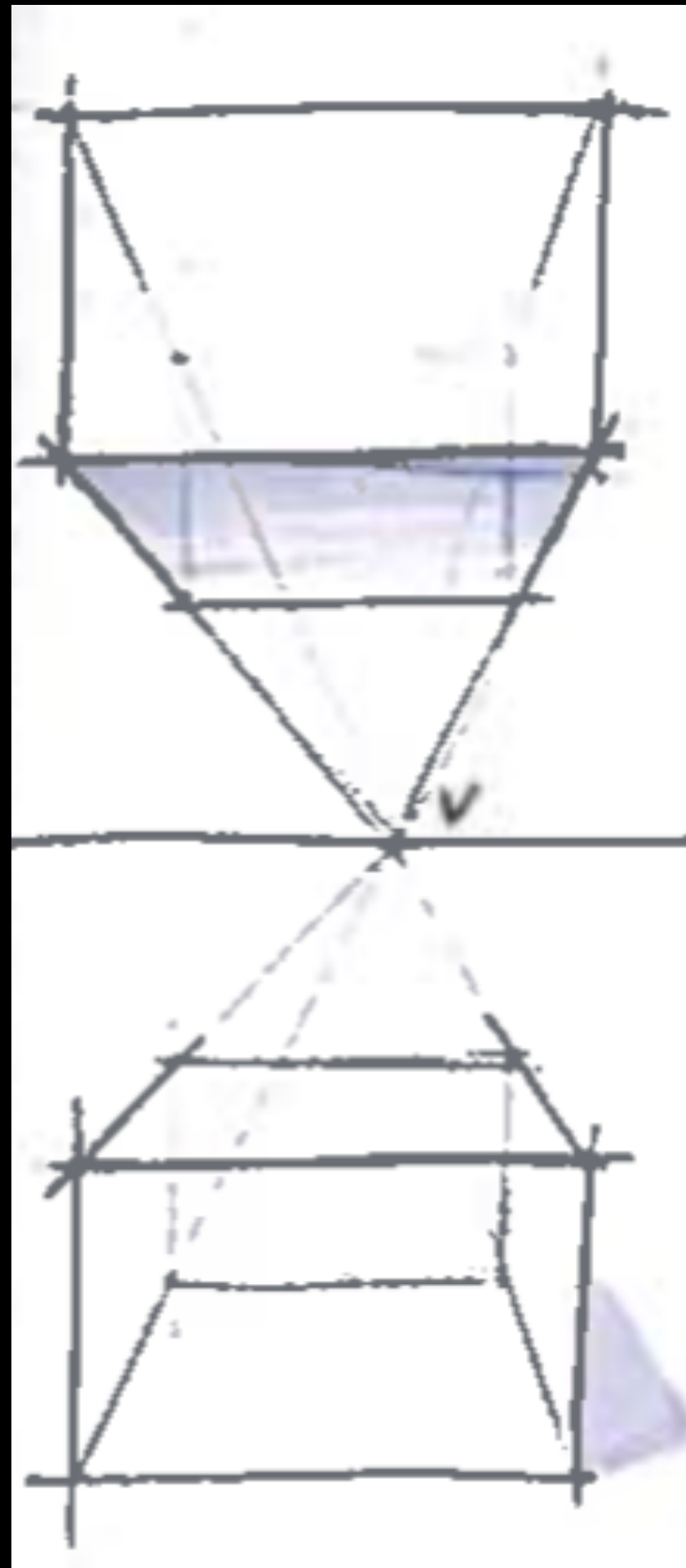

Sketching the Basics
Steur, Eissen
2011

Sketching Form

1 Point Perspective

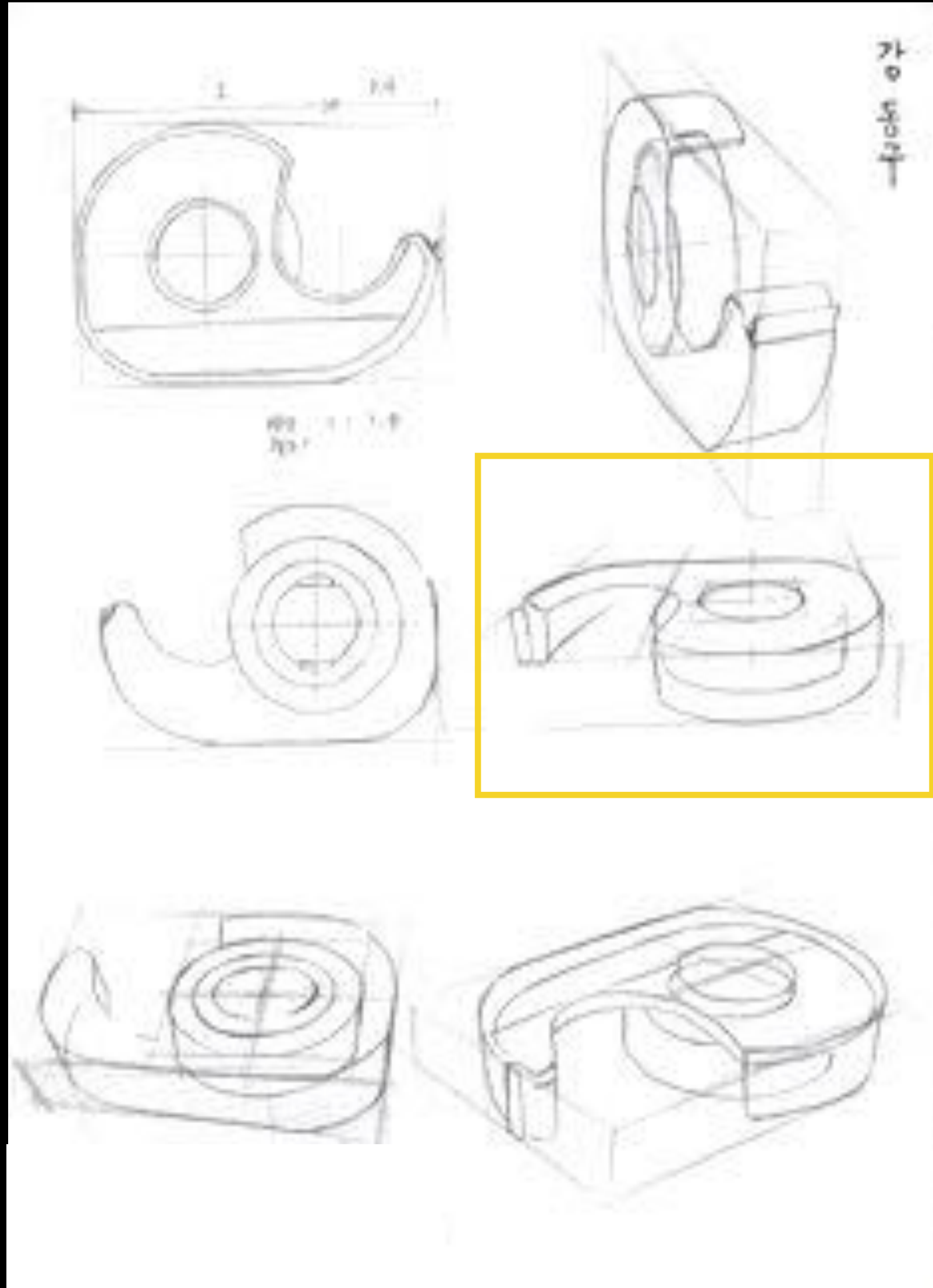

Sketching Form

1 Point Perspective

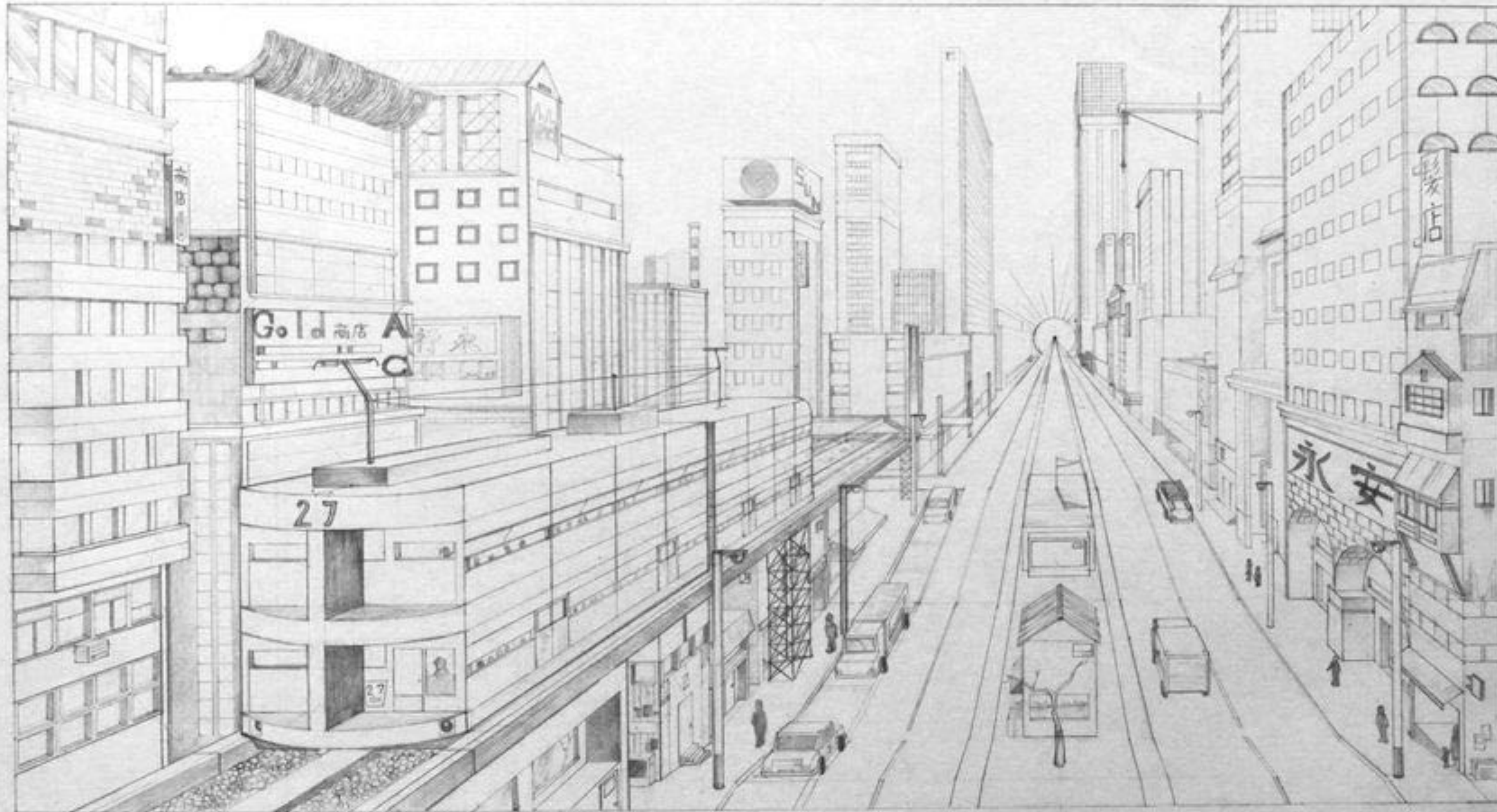

Sketching Form

1 Point Perspective



Sketching Form

1 Point Perspective

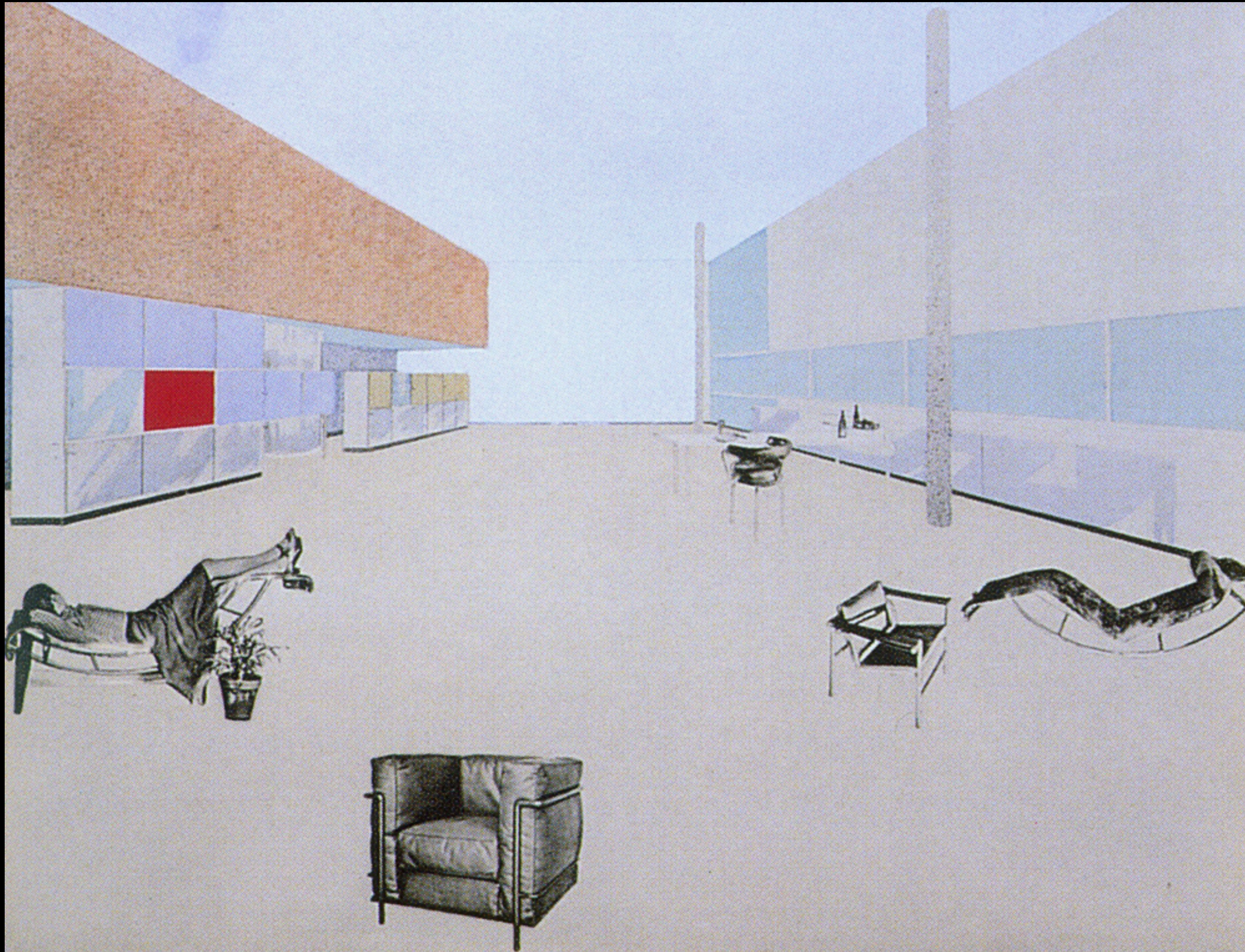

Sketching Form

1 Point Perspective

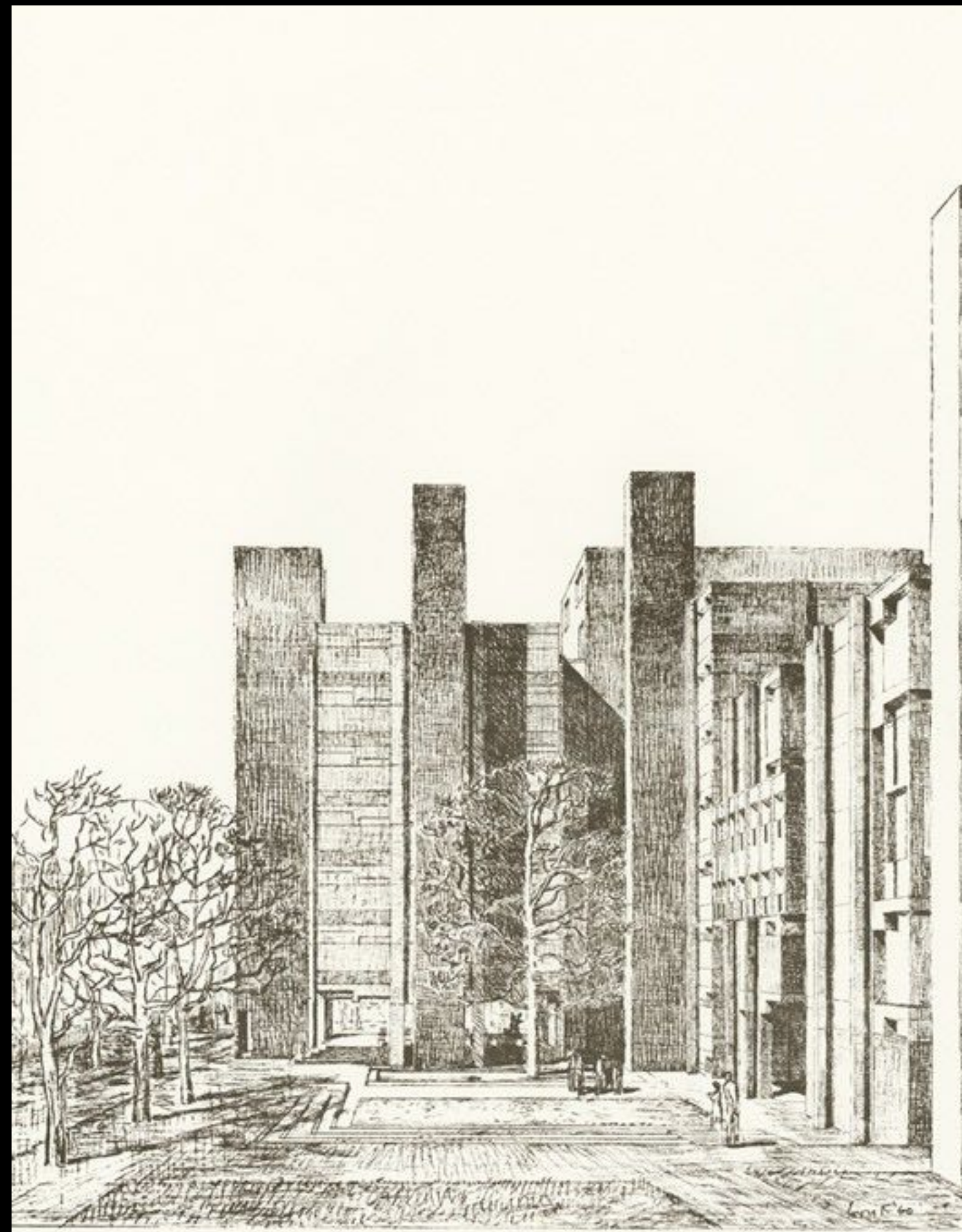

W. 1907 A. N. Richards Medical Research Building, University of Pennsylvania, Philadelphia, definitive study / 77% pencil on tracing paper / see note

Sketching Form

1 Point Perspective

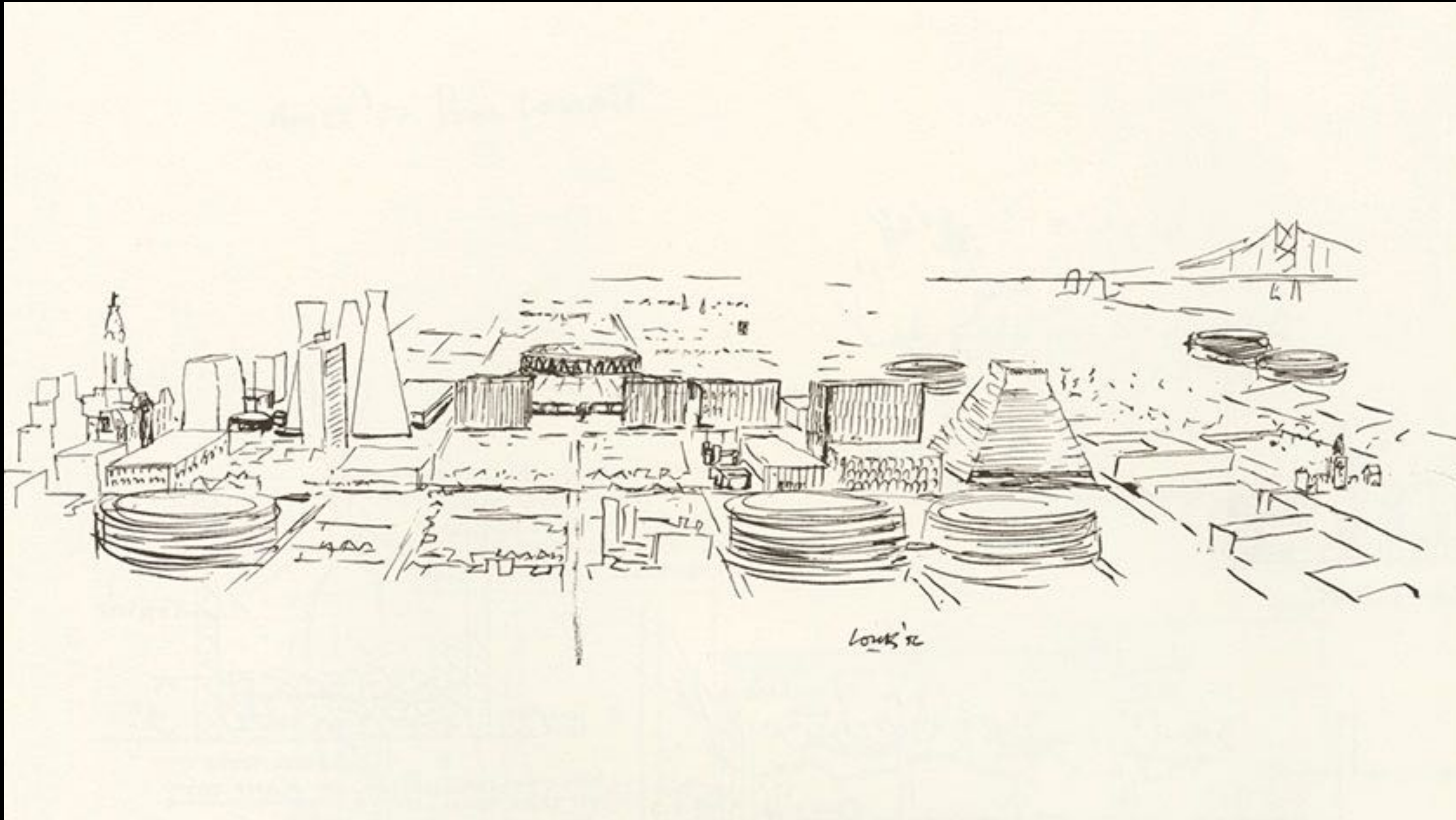

Sketching Form

1 Point Perspective

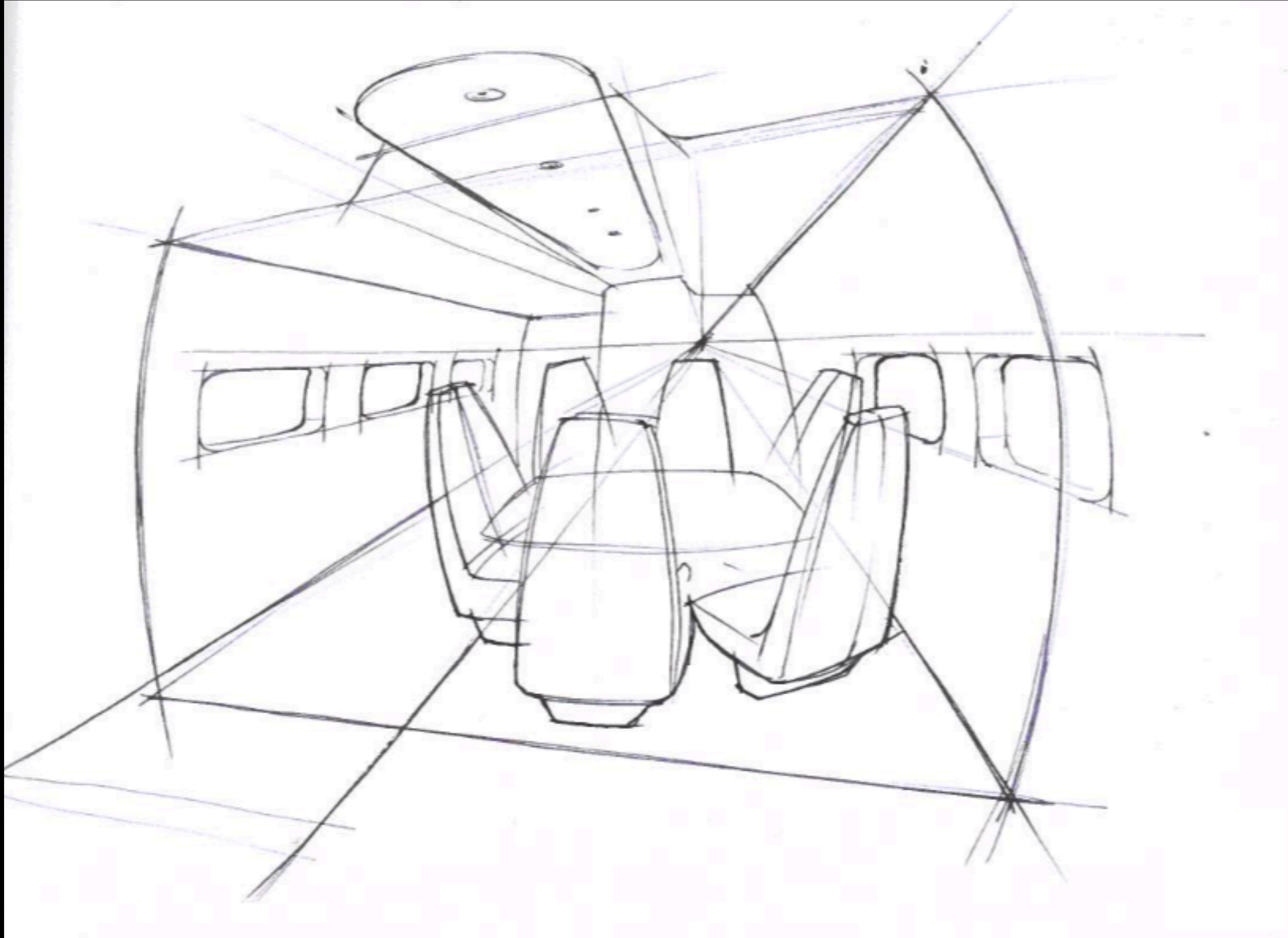

Sketching Form

1 Point Perspective

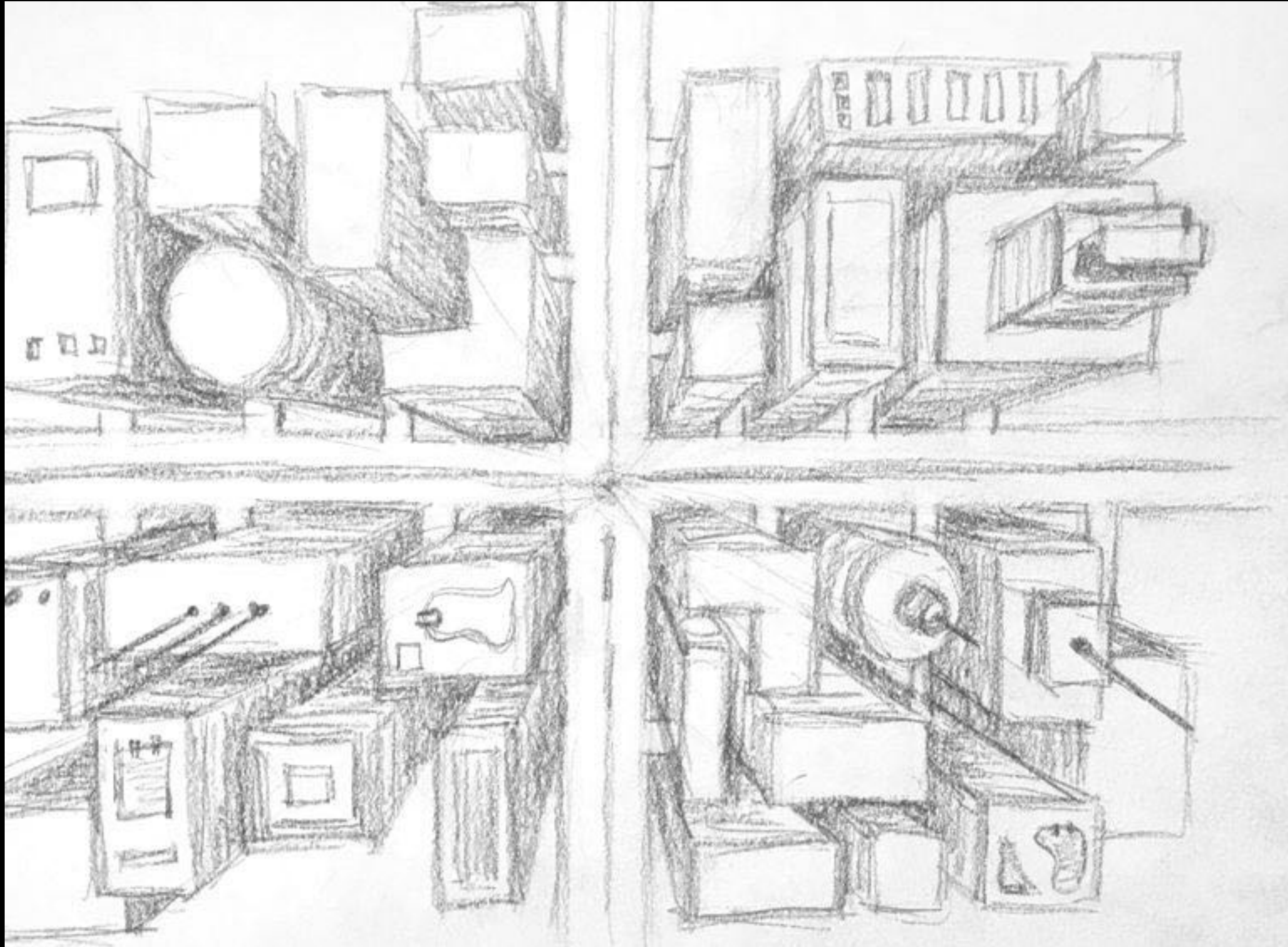

Sketching Form

1 Point Perspective

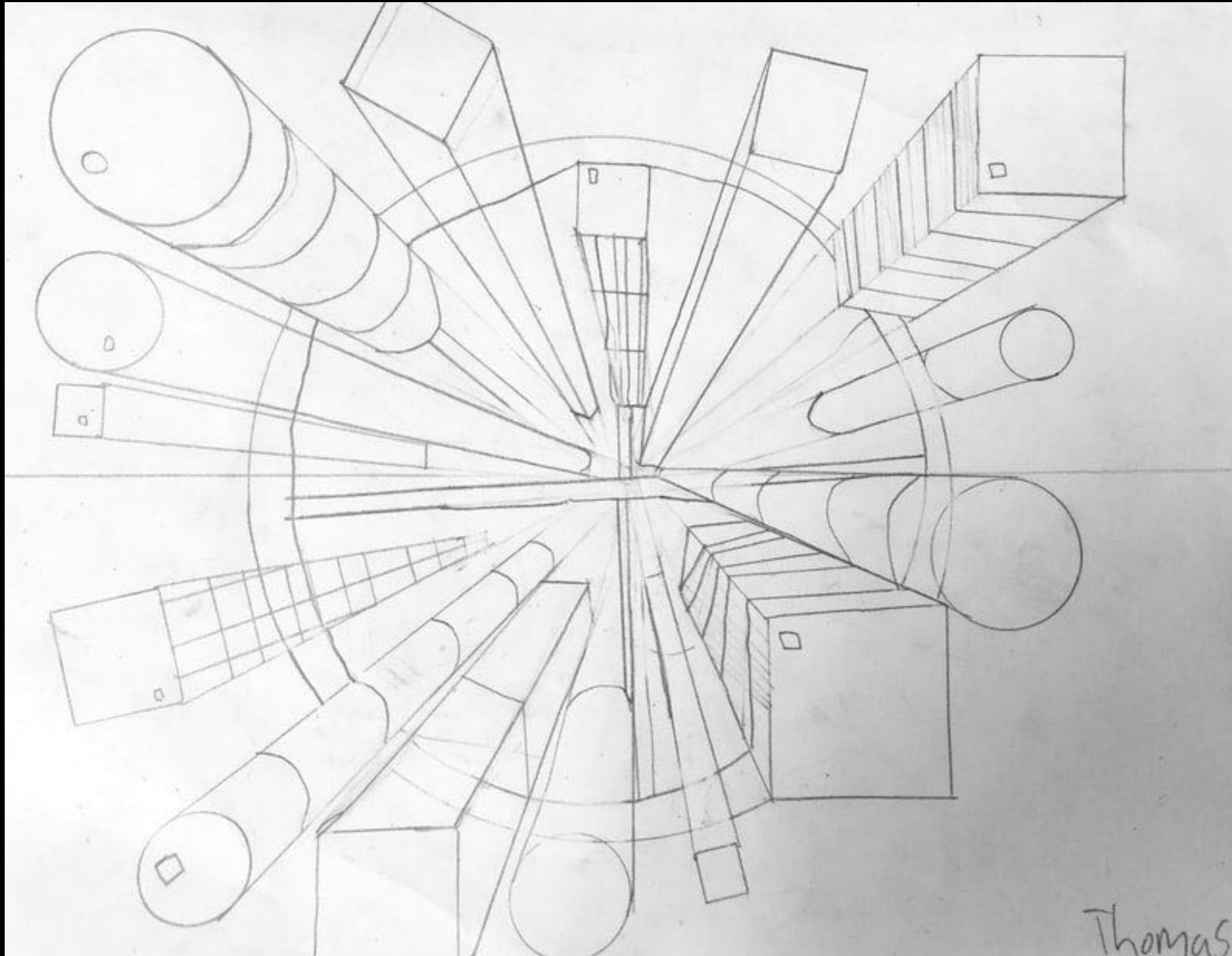

Exercise 4

1-POINT ARCHITECTURE

20 min

Exercise 5

1-POINT PERSPECTIVE

20 min

LUNCH BREAK

1 Hour

Sketching Form

2 Point Perspective

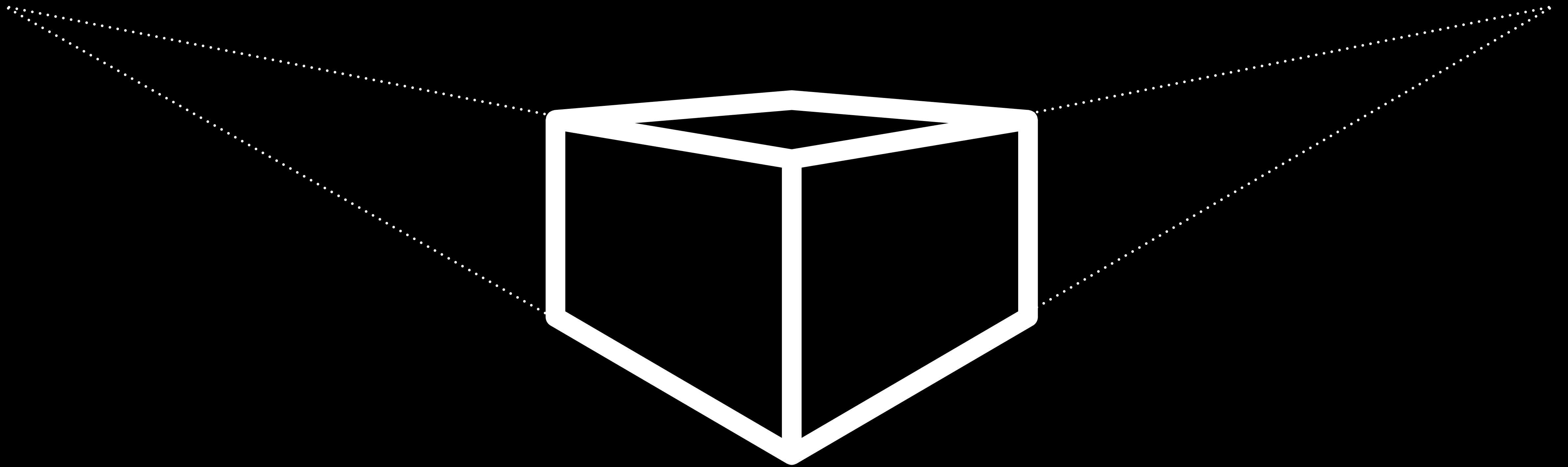

Sketching Form

2 Point Perspective

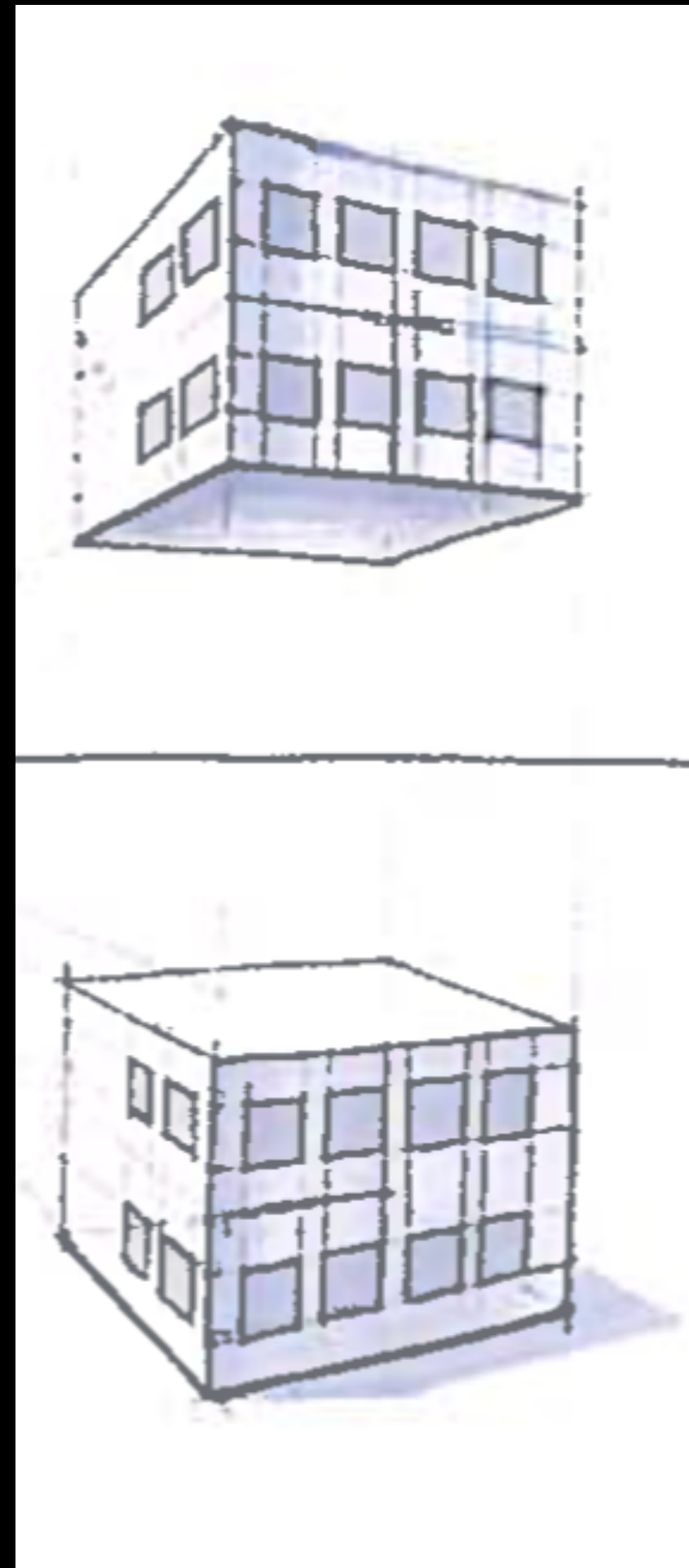

Sketching the Basics

Steur, Eissen

2011

Sketching Form

2 Point Perspective



Sketching Form

2 Point Perspective

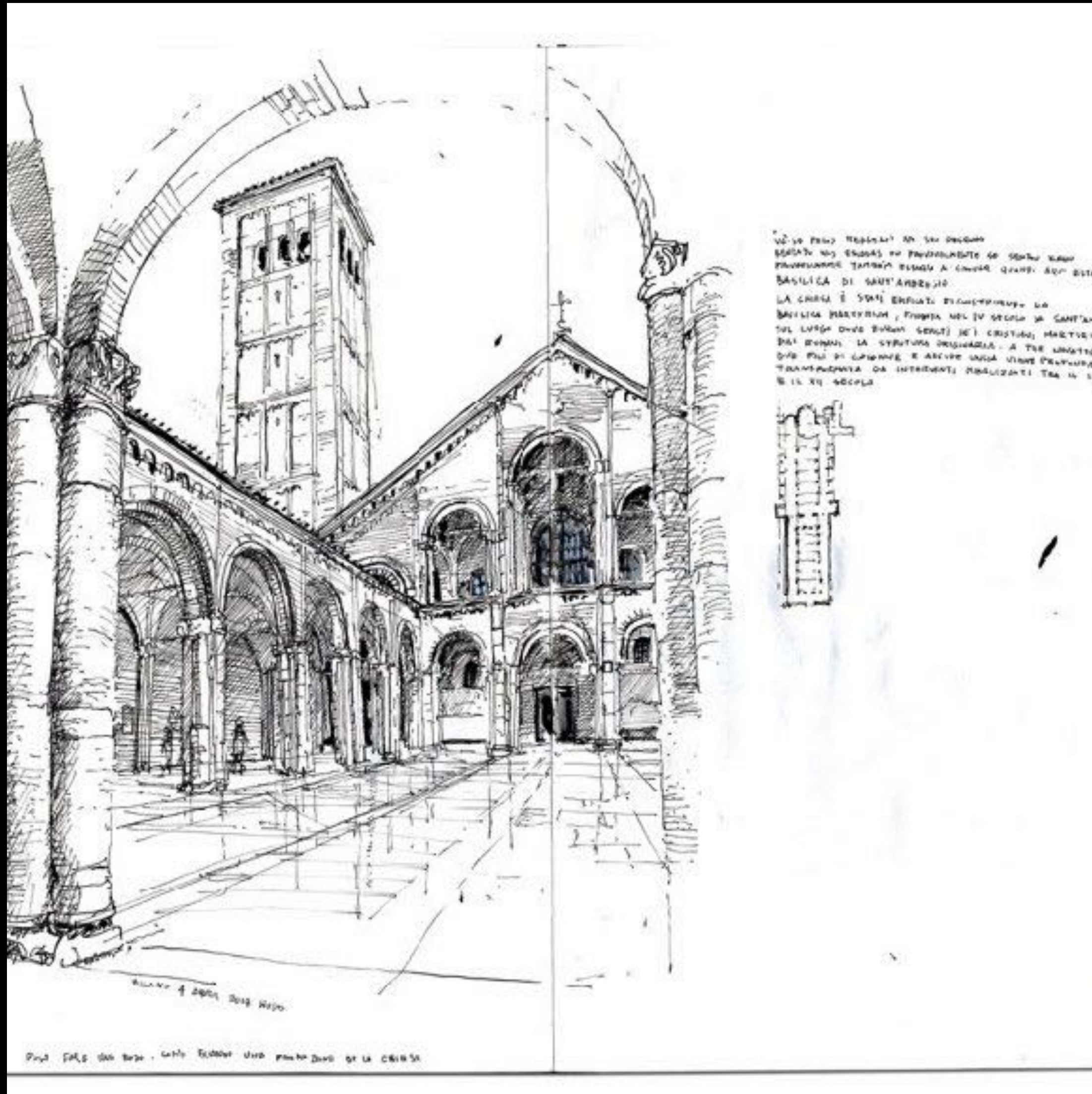

Hugo Barros Costa, Basilica of Sant'Ambrogio, 2016.

Sketching Form

2 Point Perspective

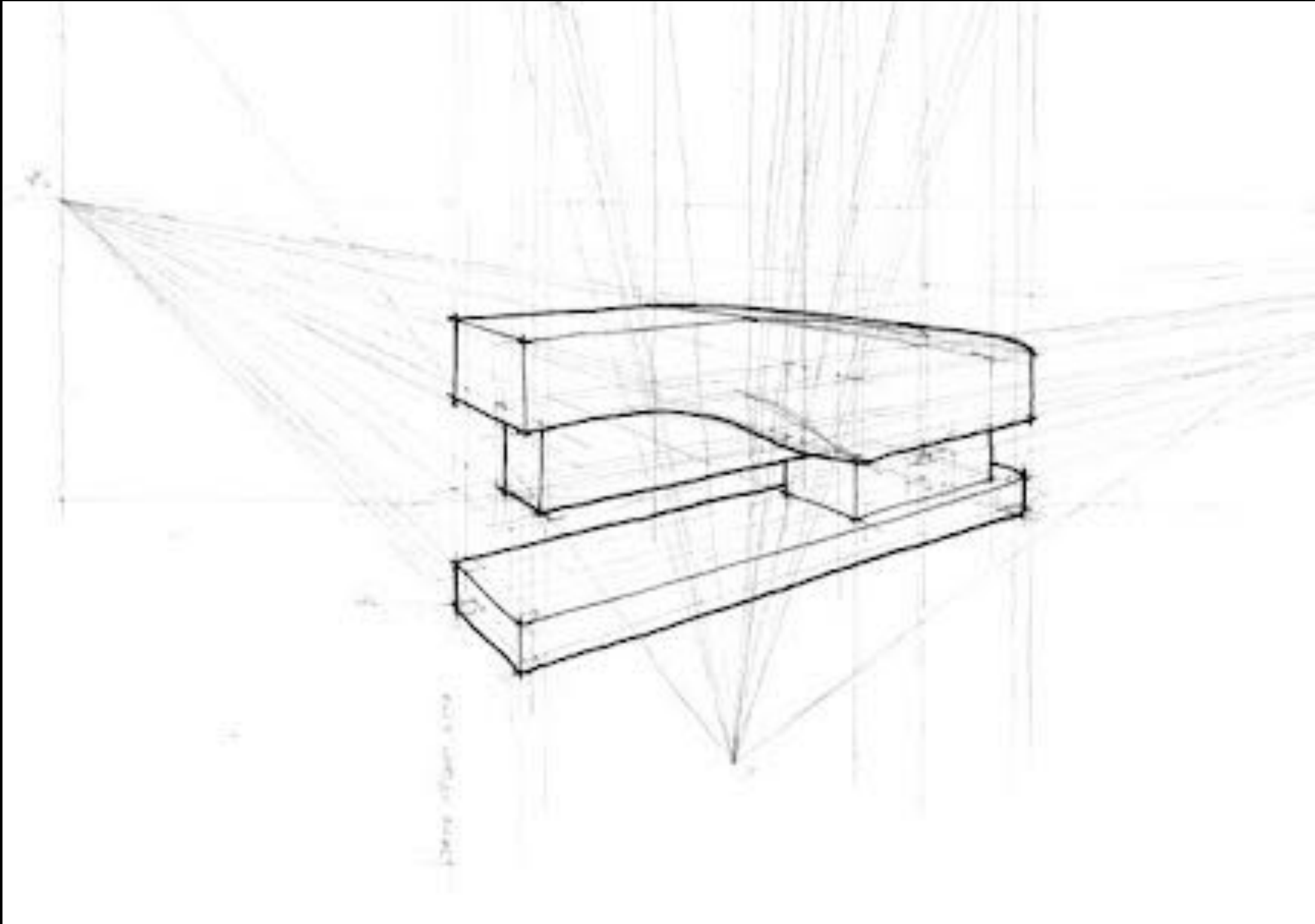

Sketching Form

2 Point Perspective

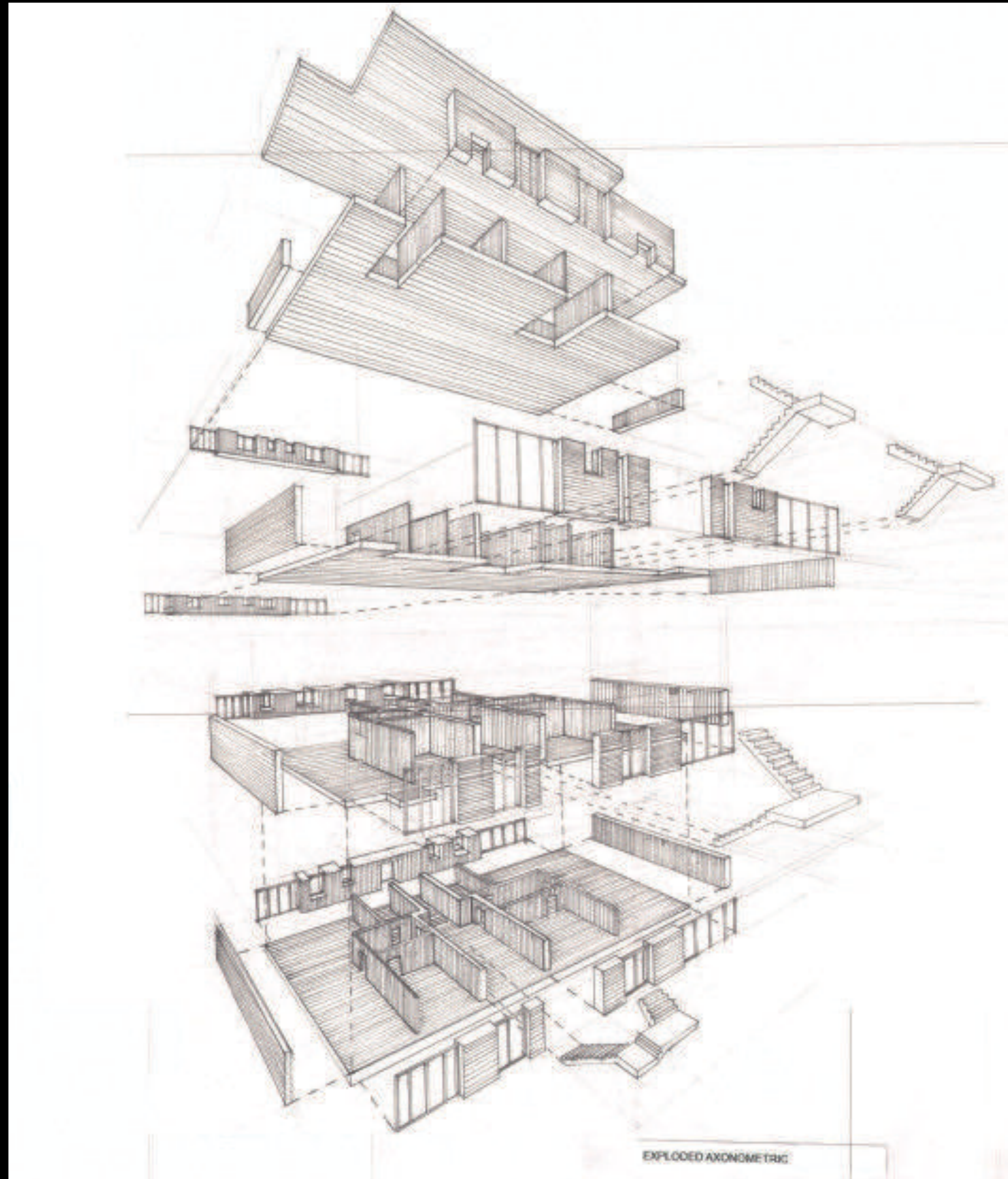

Sketching Form

2 Point Perspective

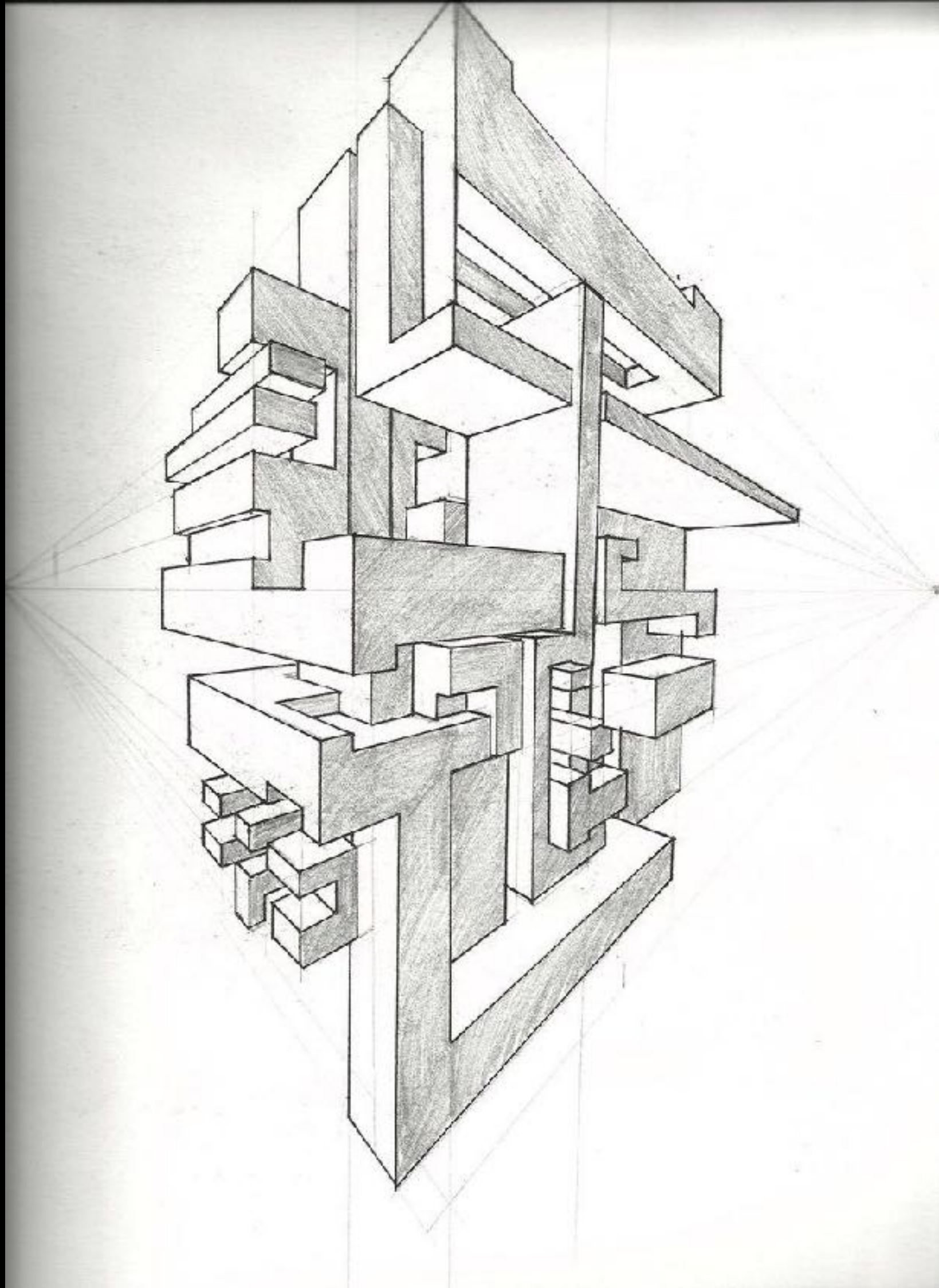

Exercise 6

2-POINT ARCHITECTURE

20 min

Exercise 7

2-POINT PERSPECTIVE

20 min

Sketching Form

3 Point Perspective

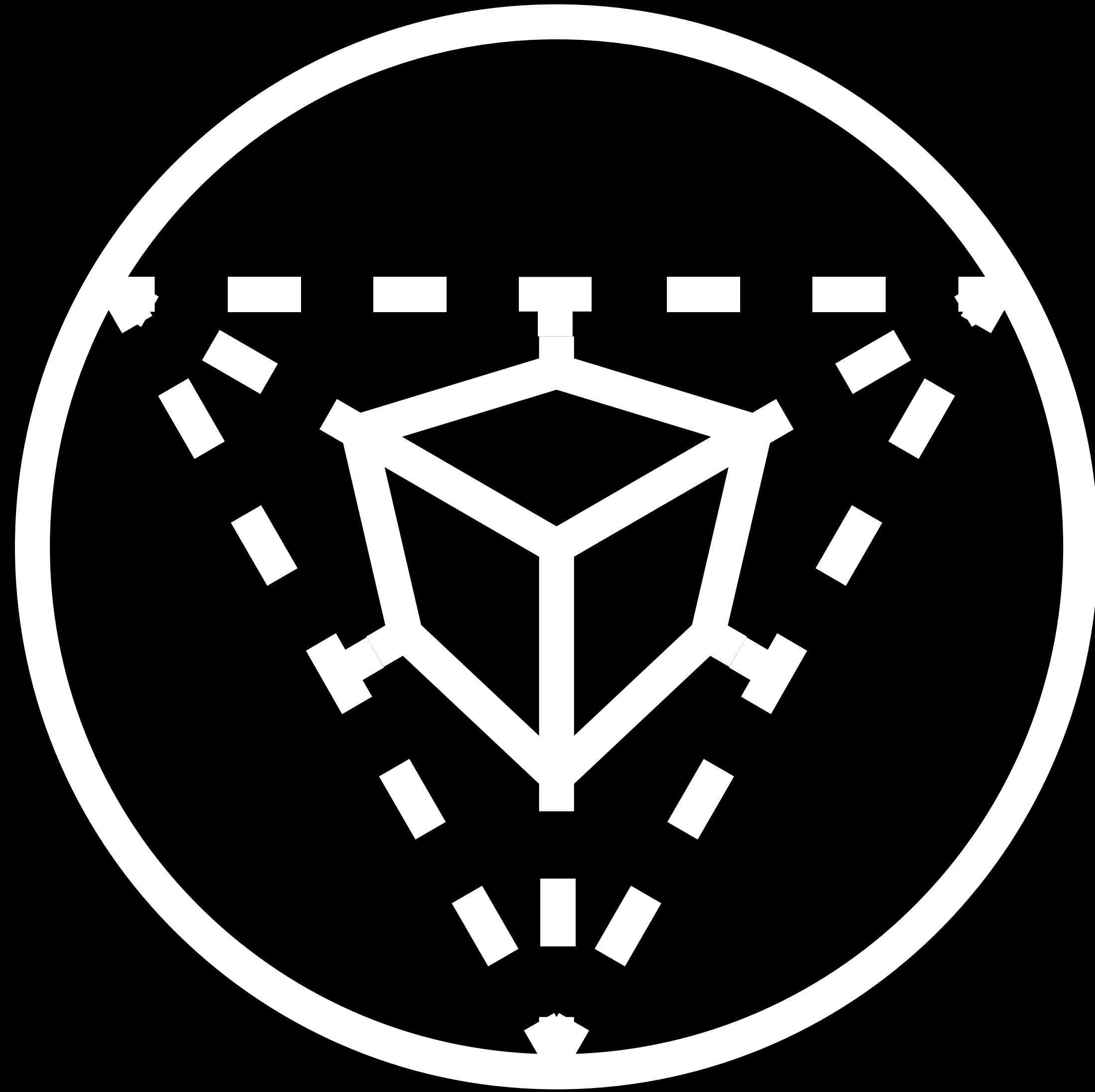

Sketching Form

3 Point Perspective

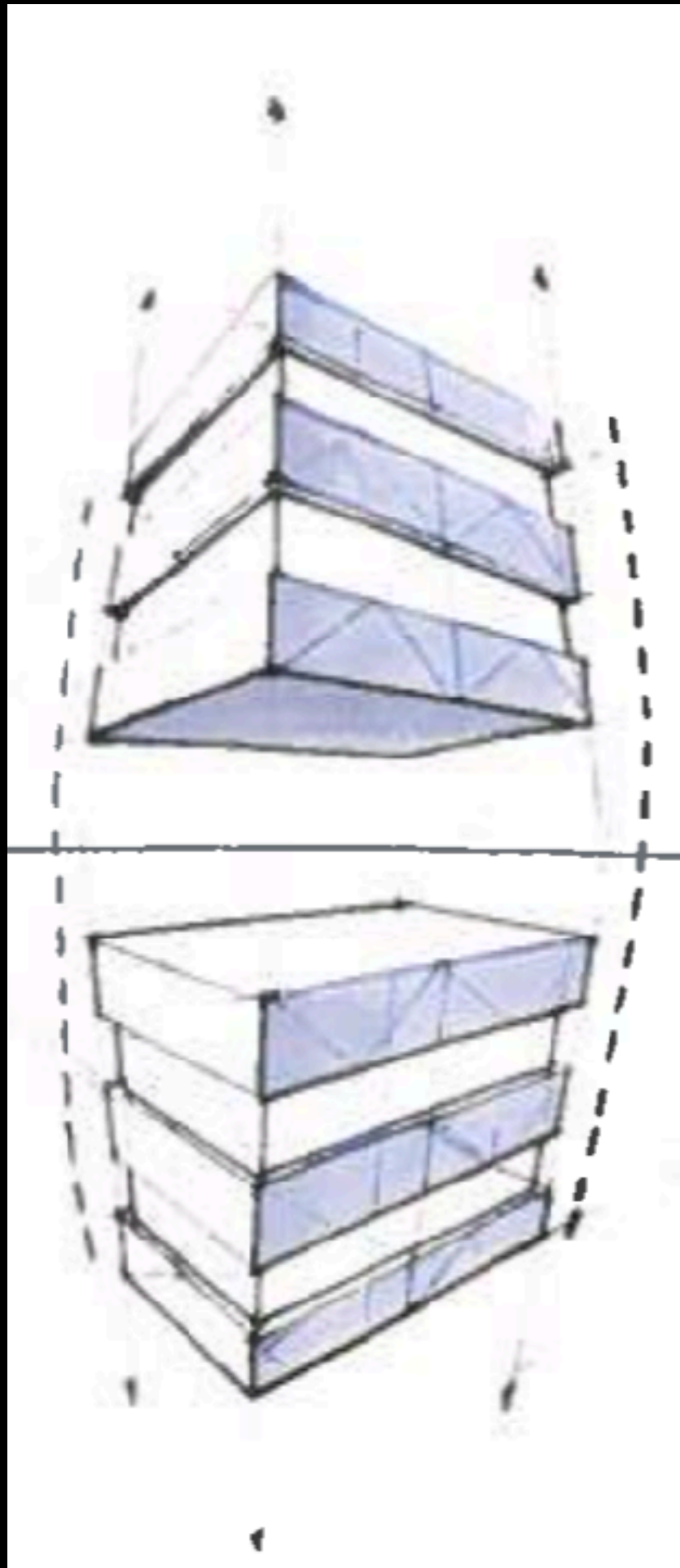

Sketching the Basics

Steur, Eissen

2011

Sketching Form

3 Point Perspective

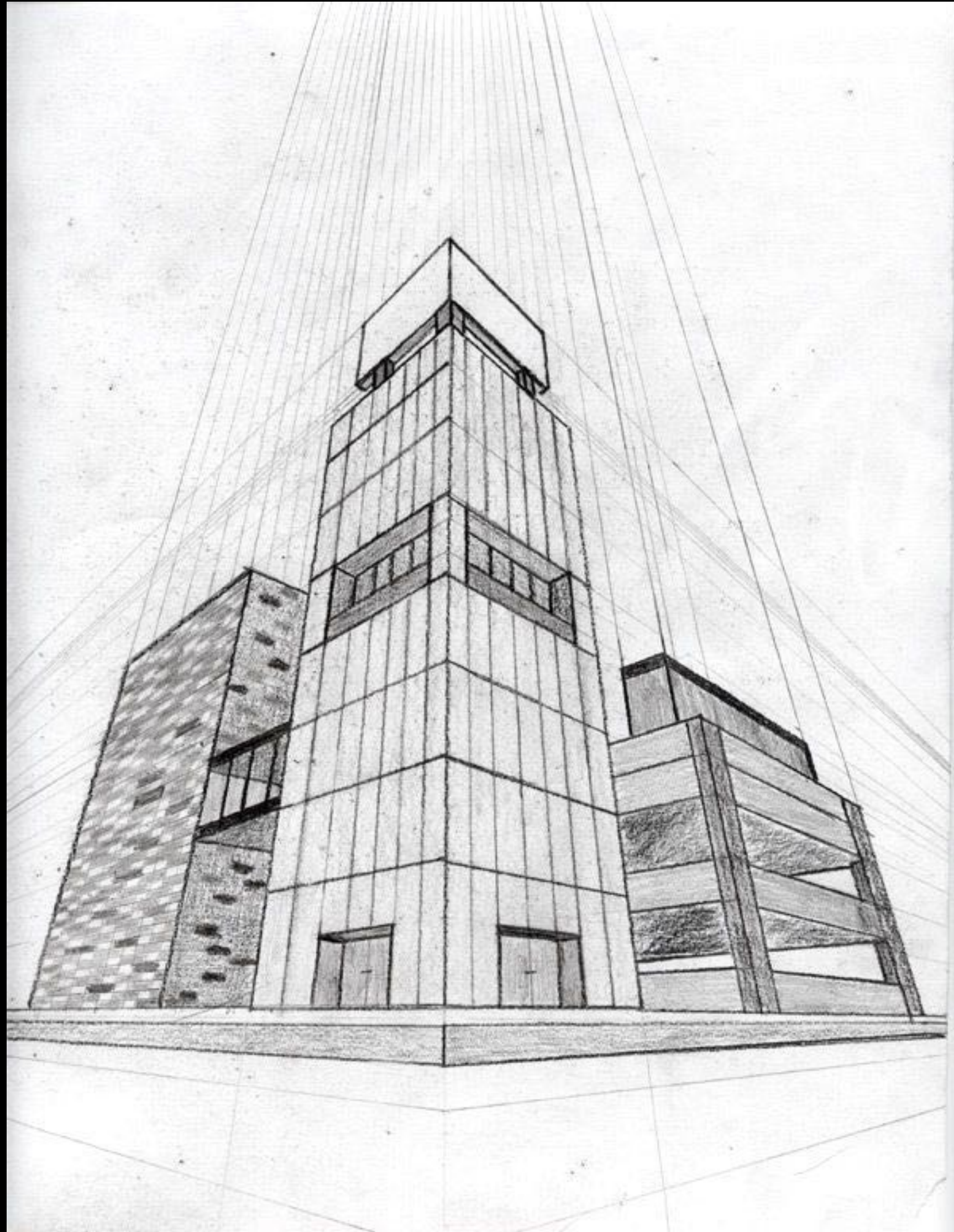

Sketching Form

3 Point Perspective

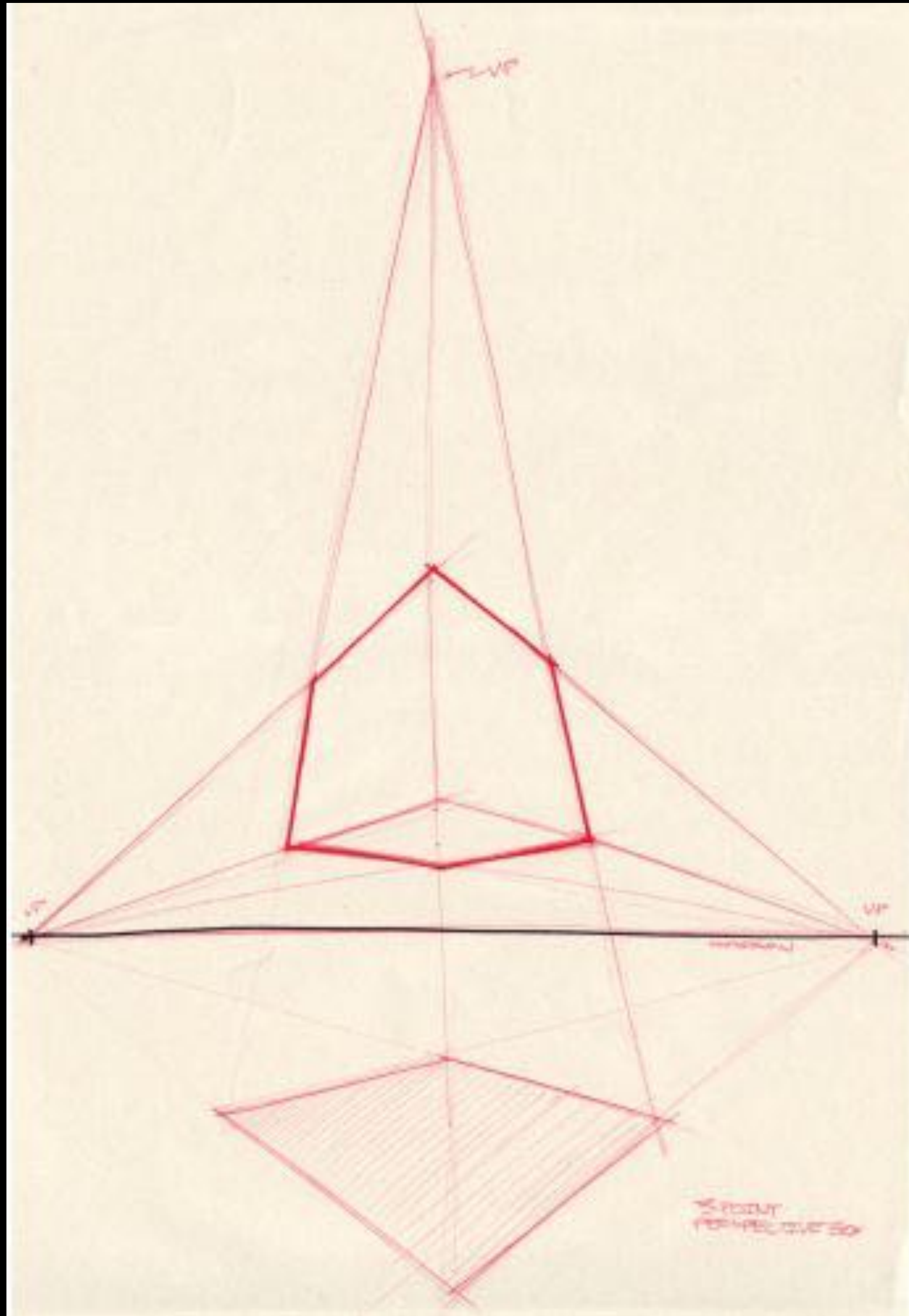

Sketching Form

3 Point Perspective

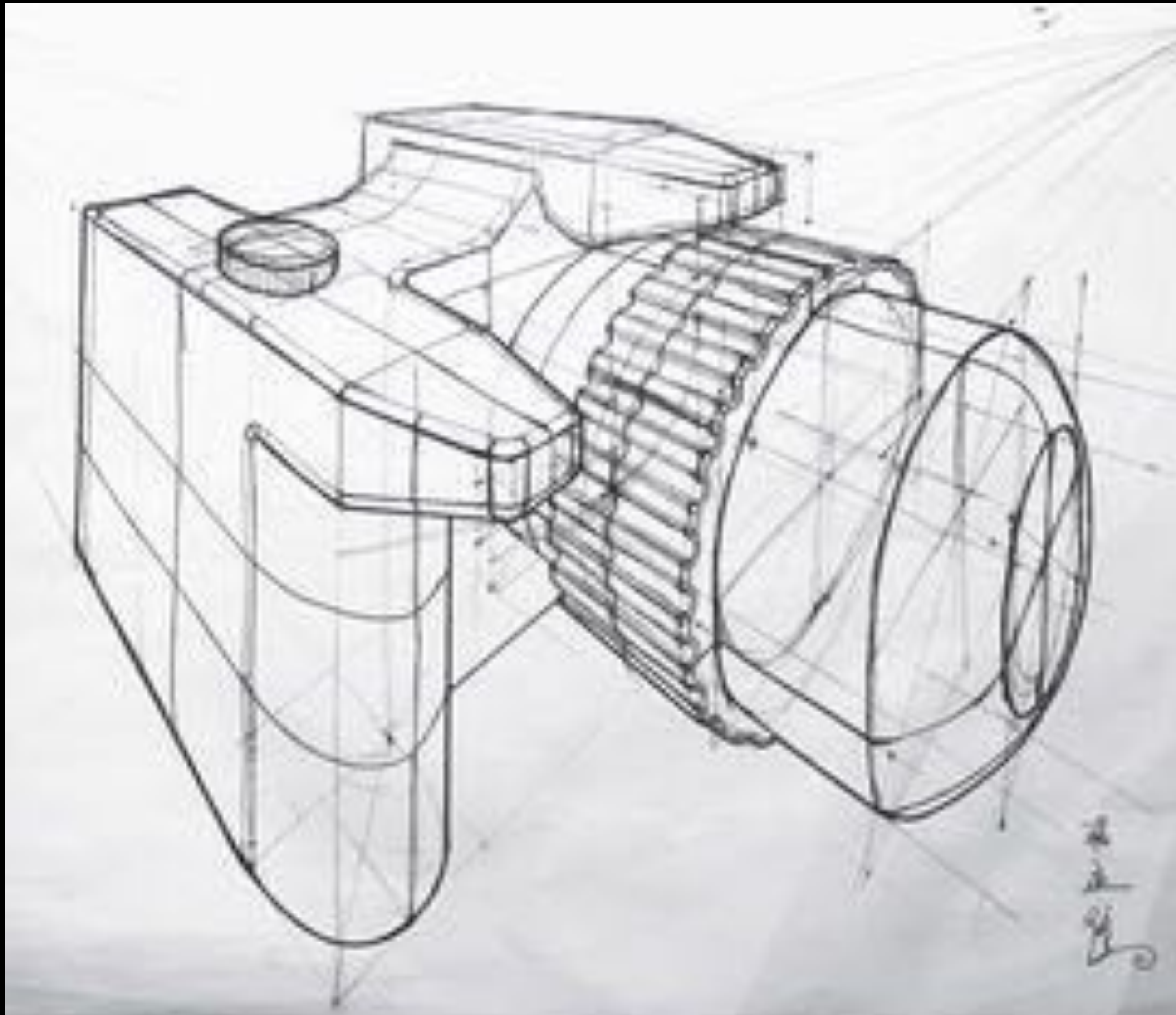

Sketching Form

3 Point Perspective

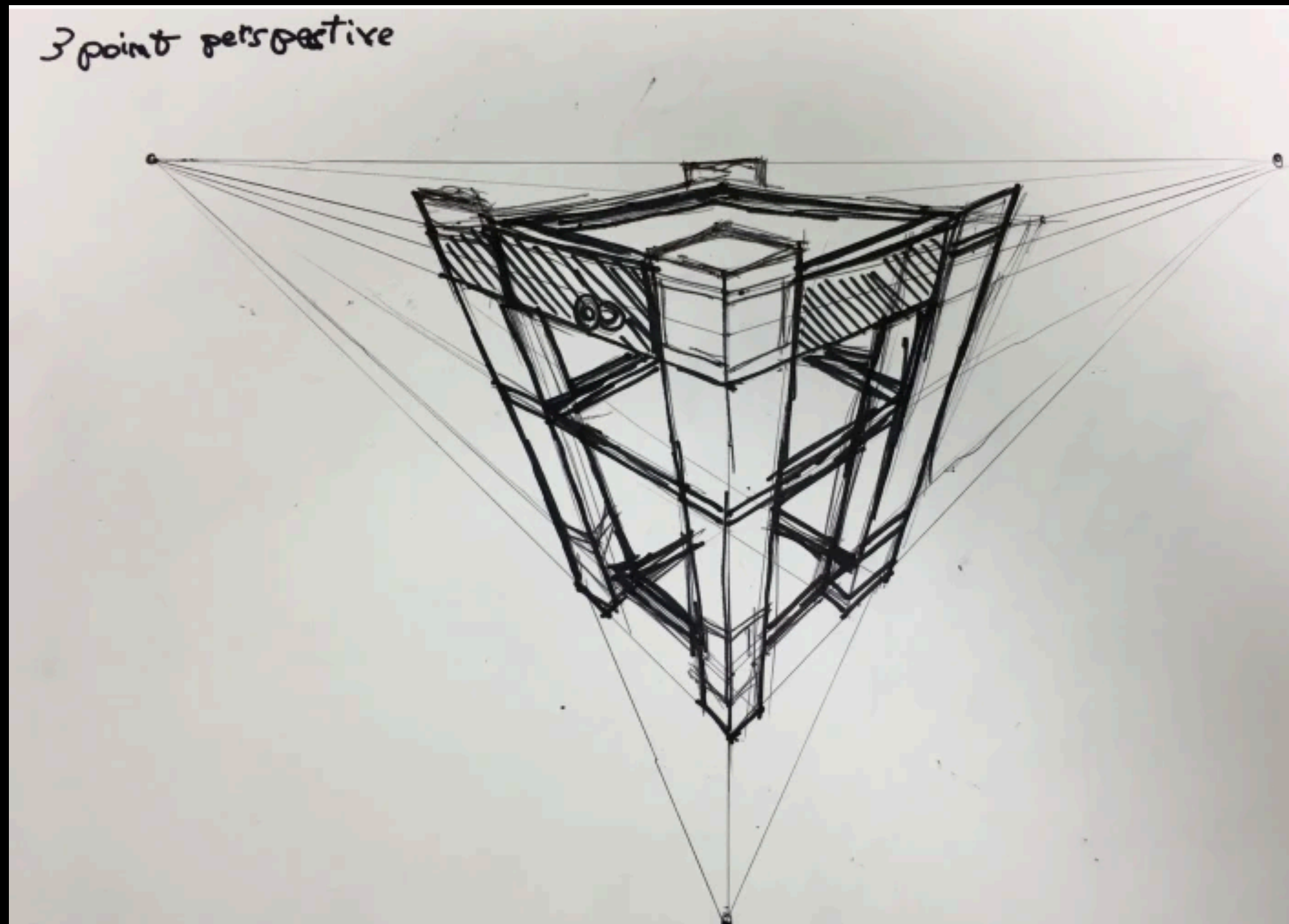

Sketching Form

3 Point Perspective

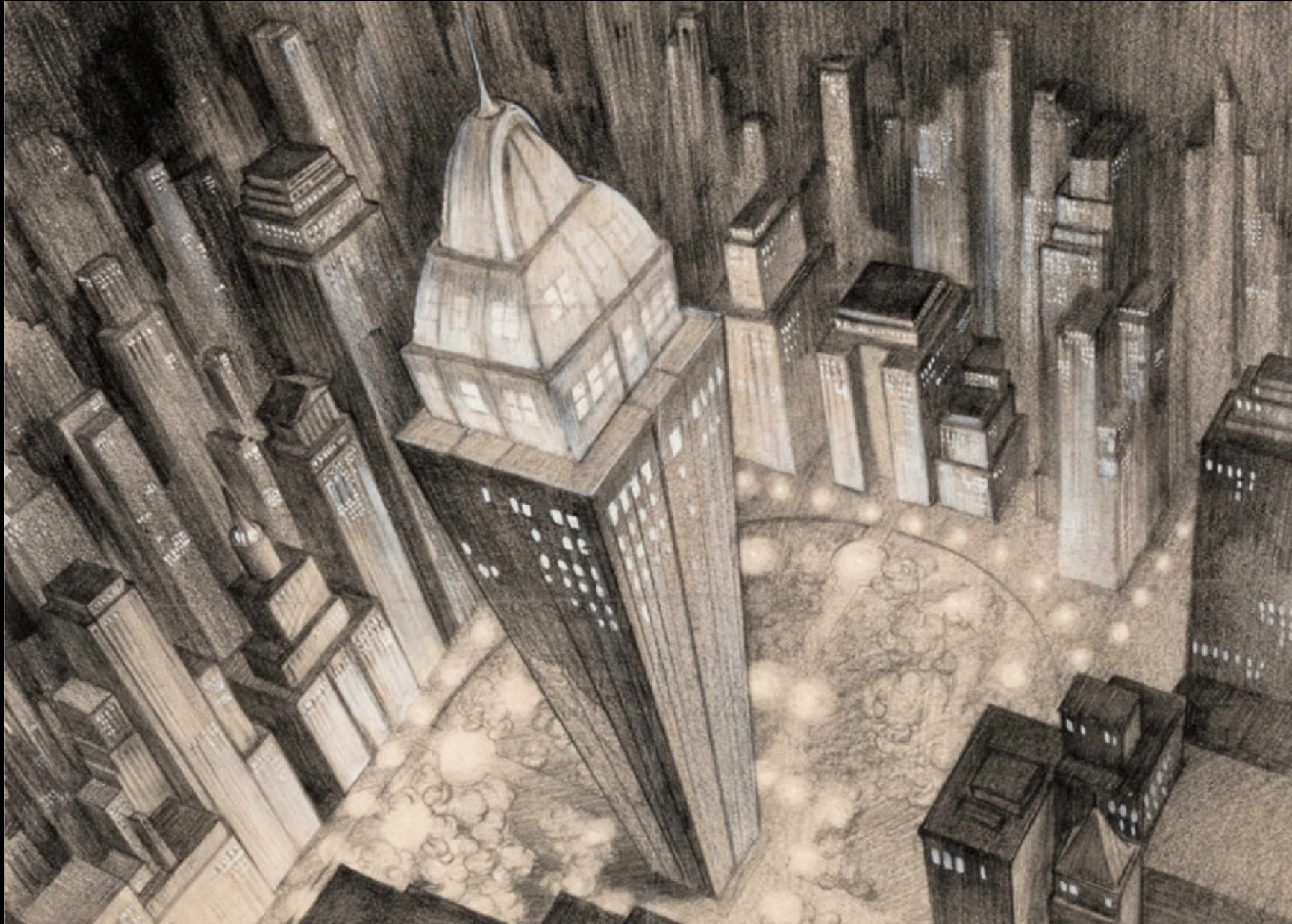

Sketching Form

3 Point Perspective

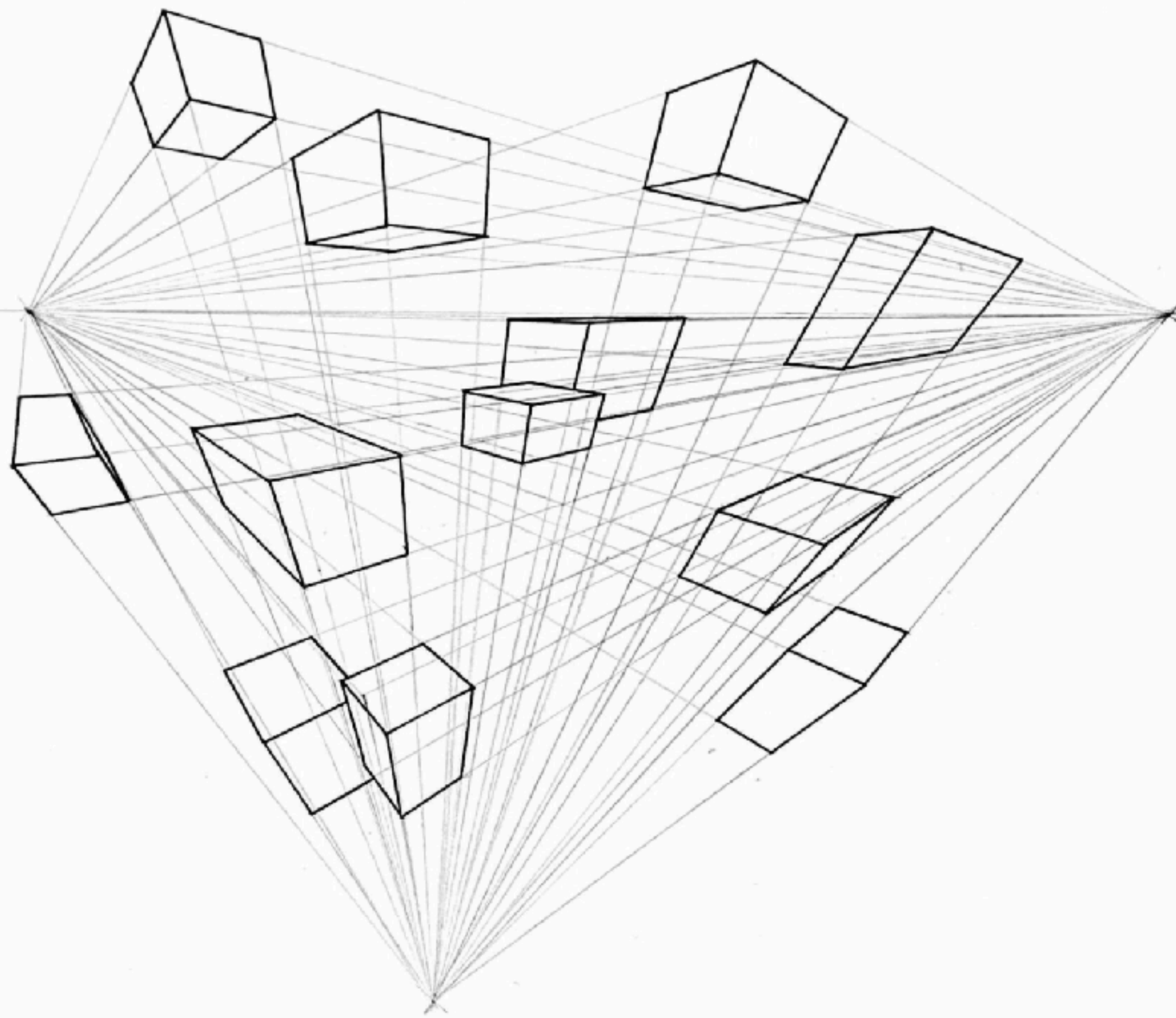

12 cubes (3 point)

Sketching Form

3 Point Perspective

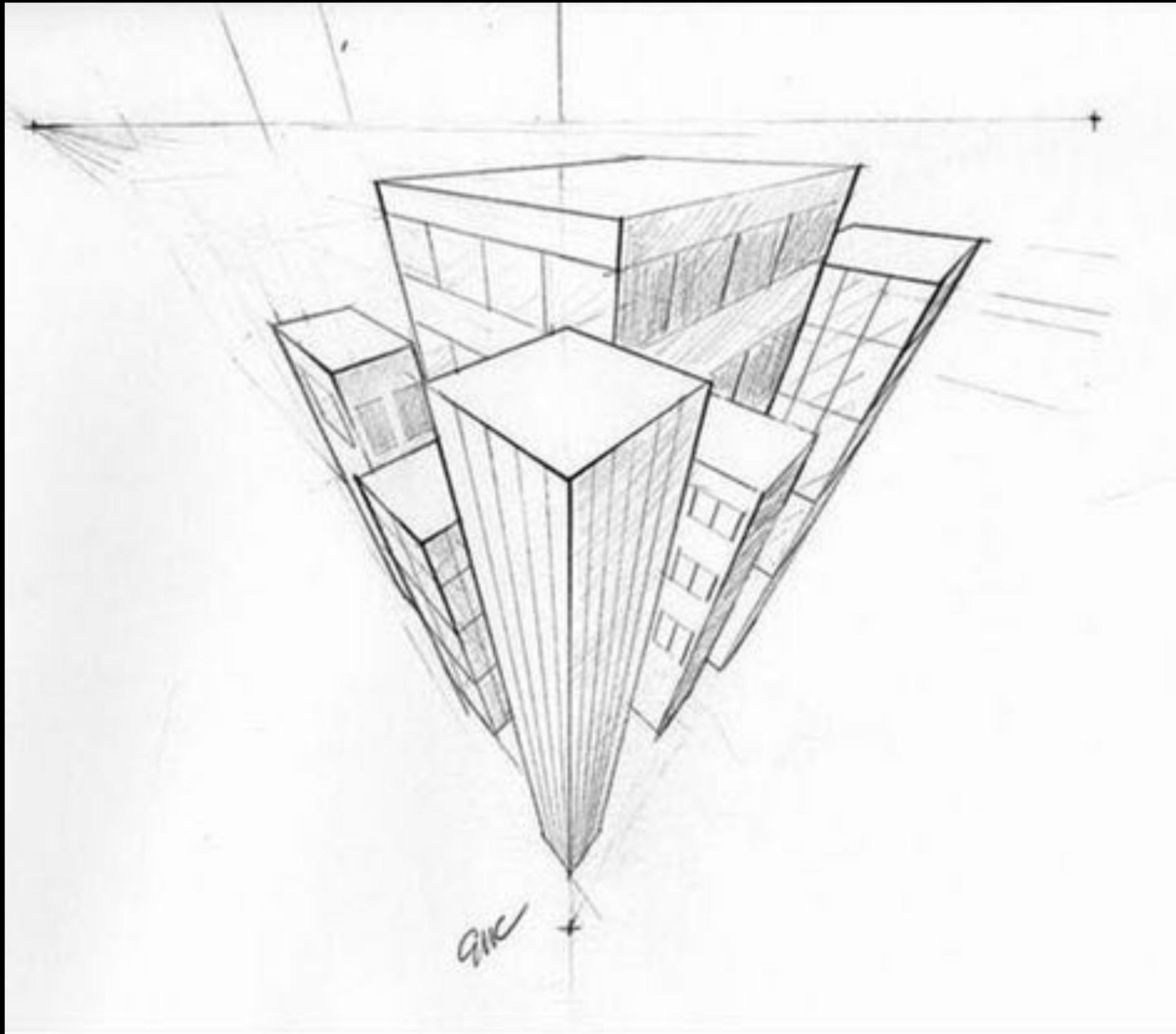

Exercise 8

3-POINT PERSPECTIVE

20 min

Exercise 9

3-POINT ARCHITECTURE

20 min

Buckminster Fuller

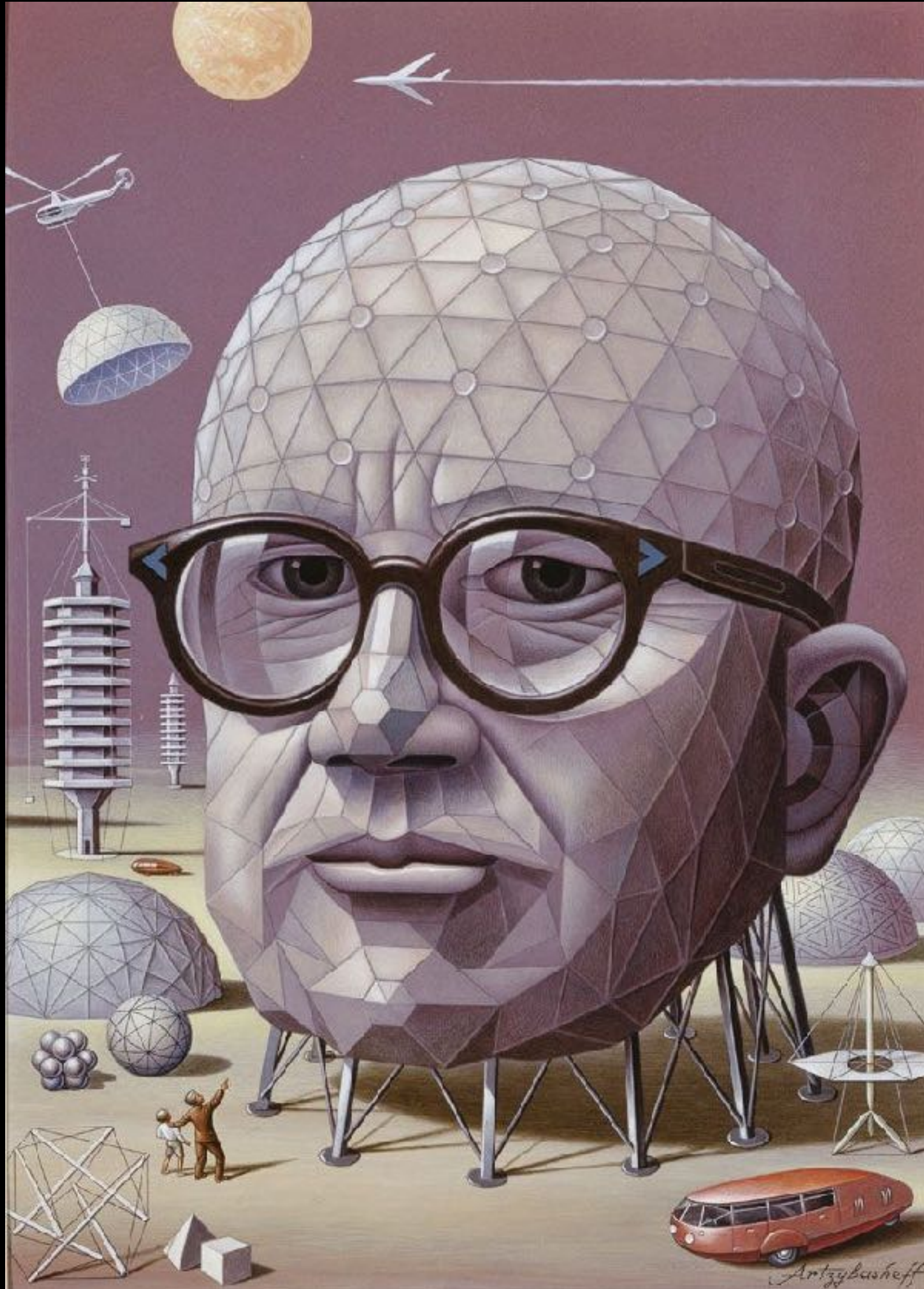
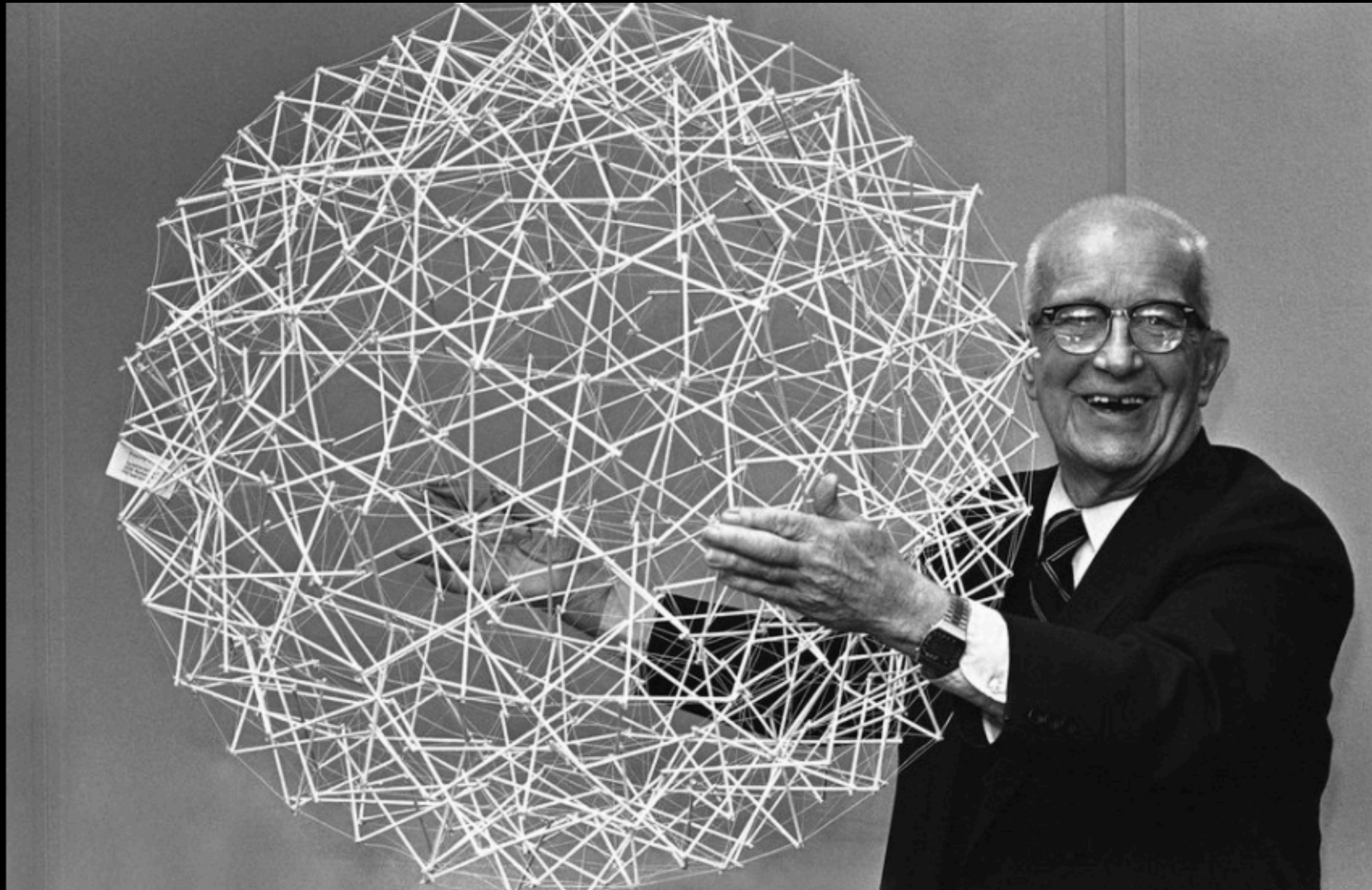

Image by: Boris Atzybasheff for Time Magazine 1964

Also see:

- [99% invisible on Buckminster Fuller](#)
- [Wikipedia on Buckminster Fuller](#)
- [Wikipedia on geodesic domes](#)

Buckminster Fuller - The Person



1895-1983

Image: Buckminster Fuller with Model of Tensegrity Sphere, 1979.

Buckminster Fuller - Sketches

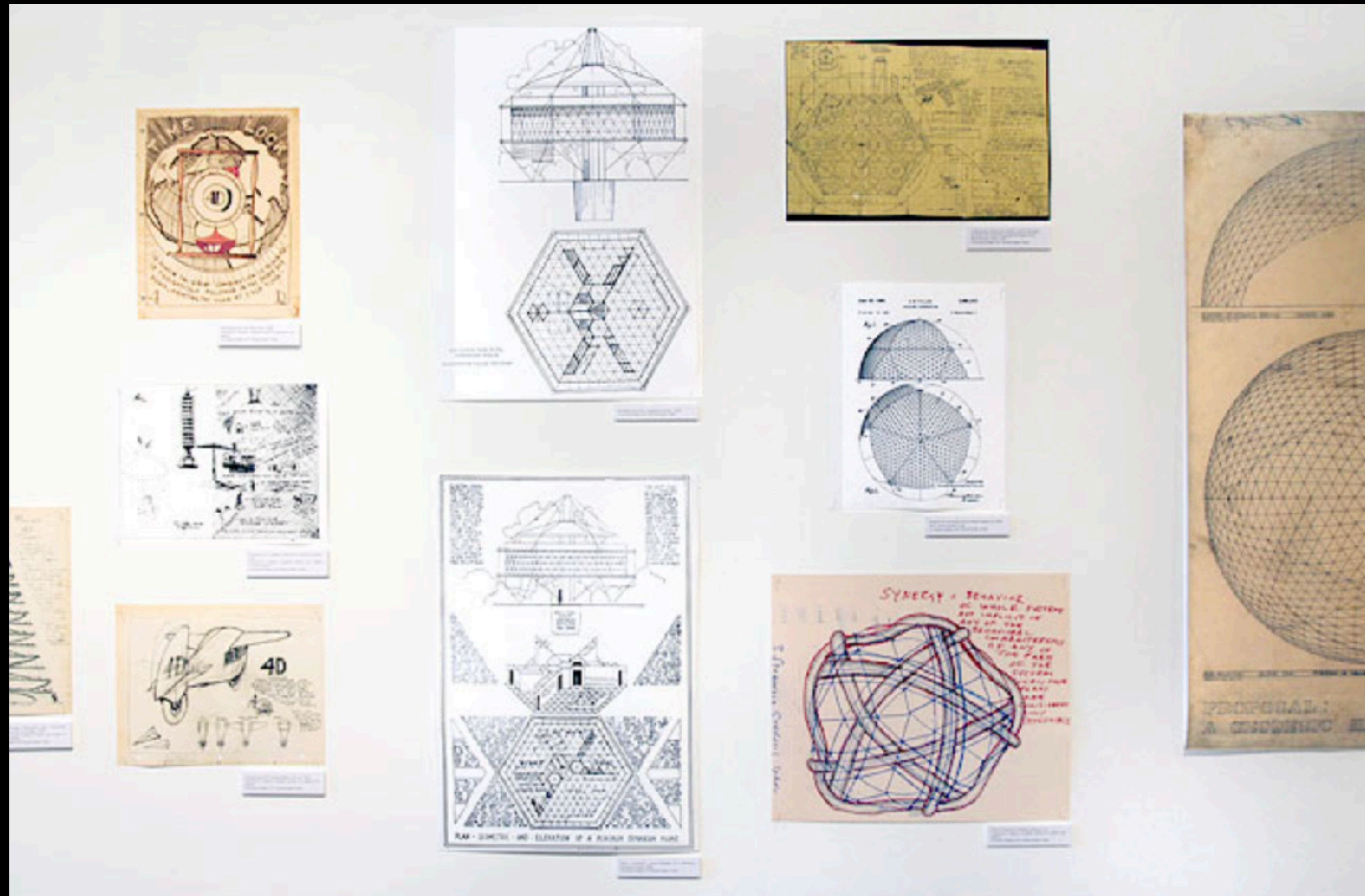
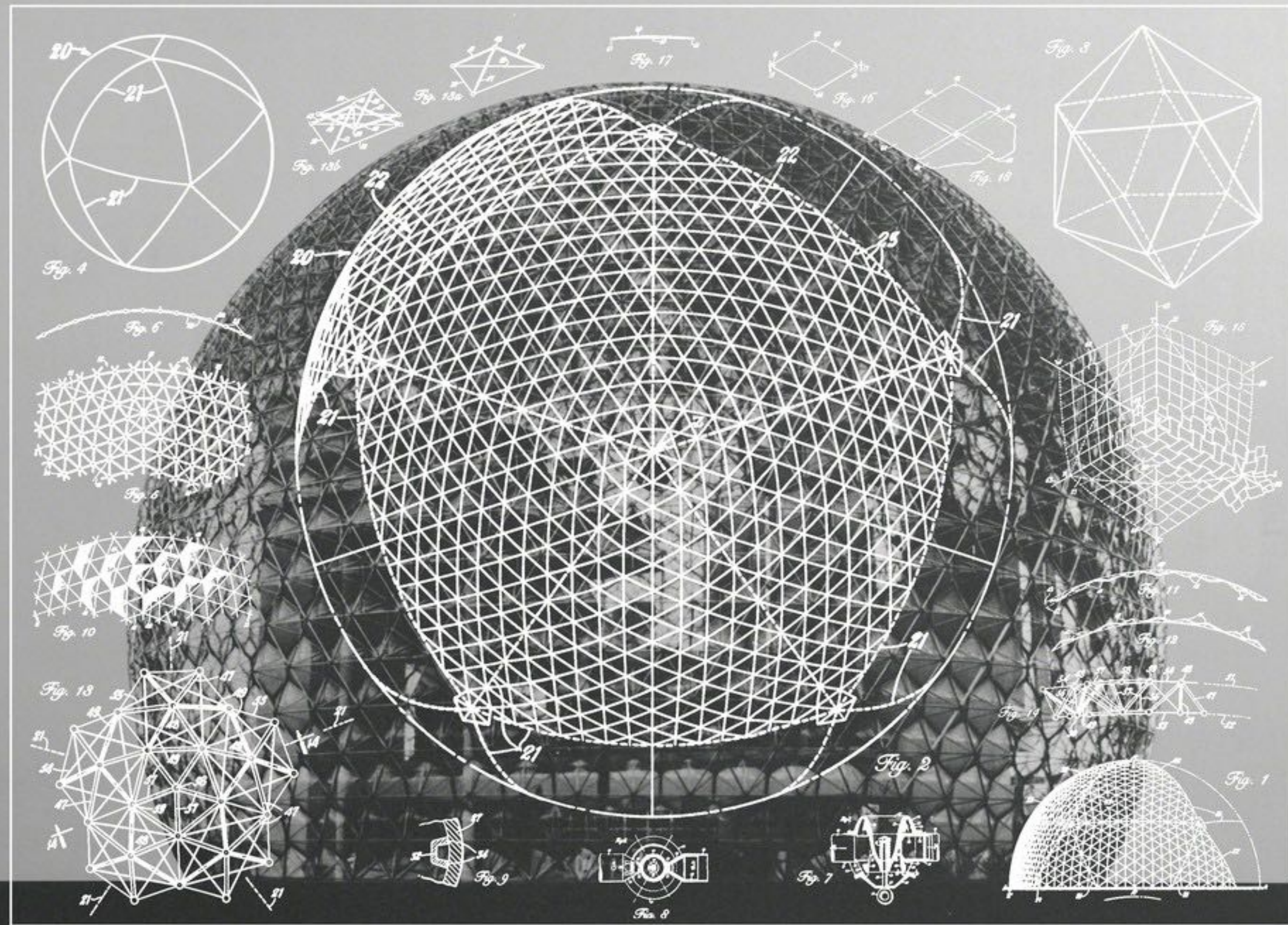
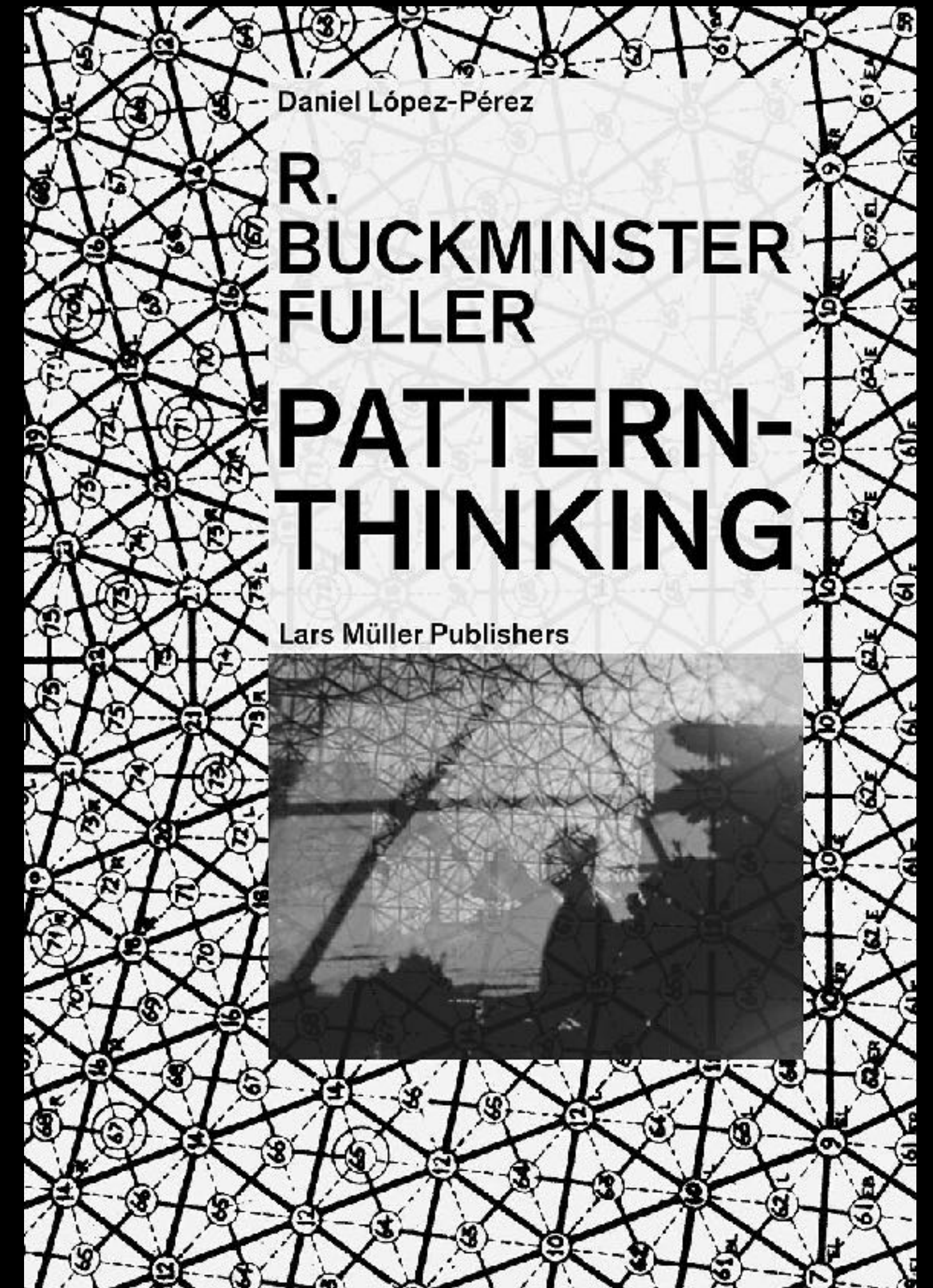

Image: Buckminster Fuller sketches

Buckminster Fuller - Geodesic Dome



BUILDING CONSTRUCTION/GEODESIC DOME, United States Patent Office no. 2,682,235, filed December 12, 1951, serial no. 261,168, granted June 29, 1954, inventor: Buckminster Fuller © 1954 Buckminster Fuller



Buckminster Fuller - Dymaxion Map

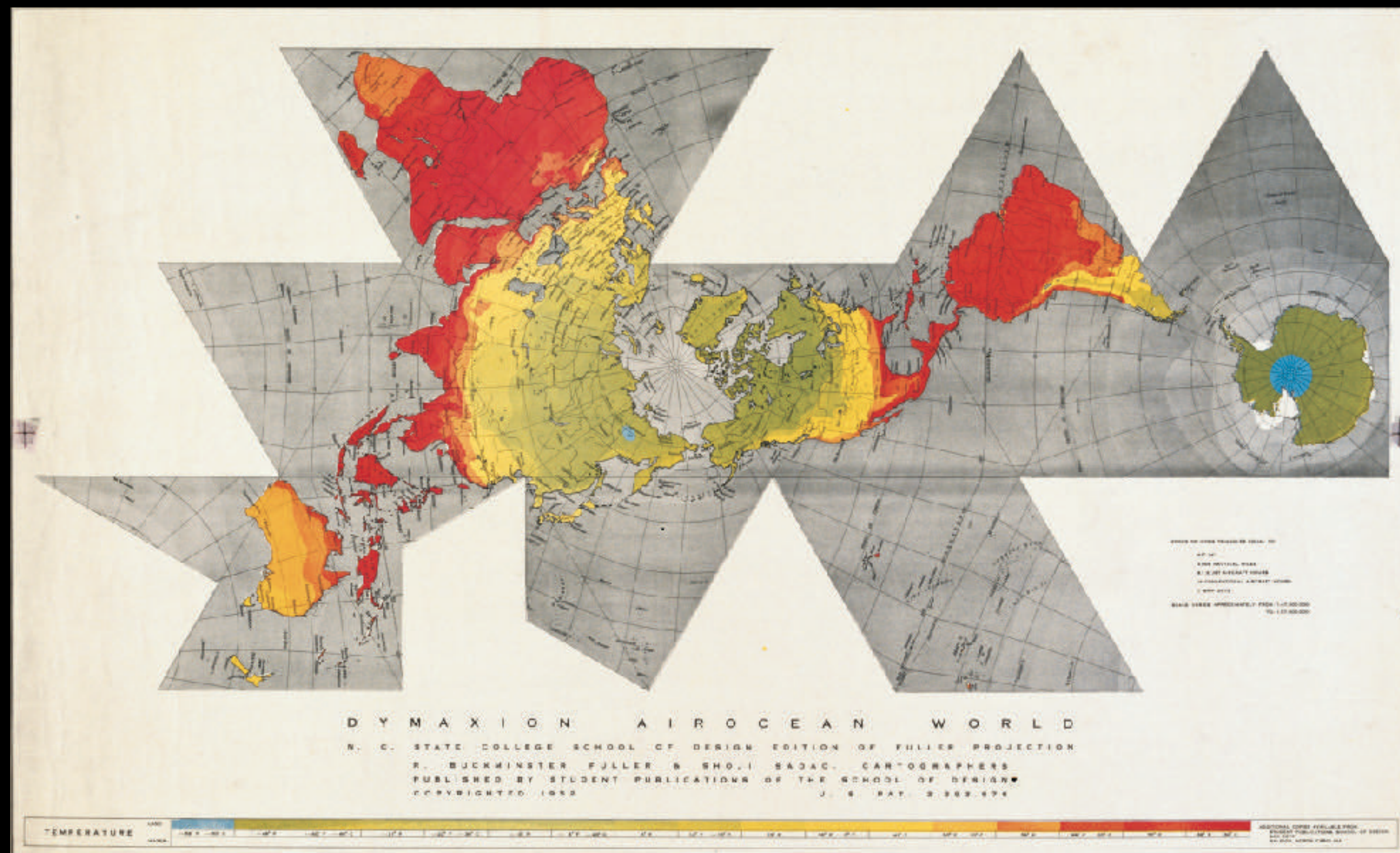

Courtesy Buckminster Fuller Institute

Performer folds Dymaxion Map, Getty Images

Buckminster Fuller Inspired Design

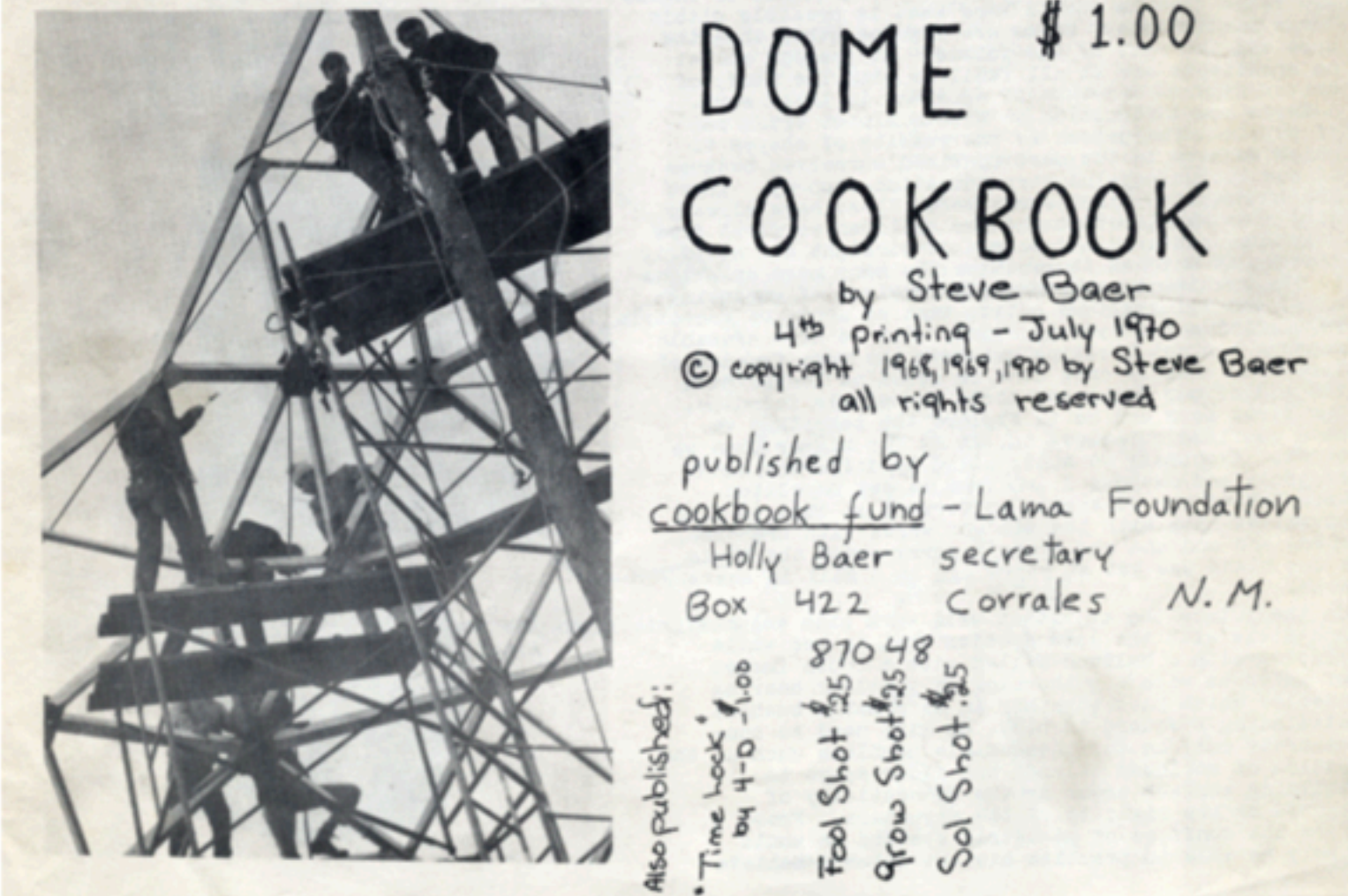

Steve Baer. *Dome Cookbook* (Lama Foundation, 1967).



Biosphere II, Arizona, 1999.



Dome of Visions, Copenhagen, Danish architects Kristoffer Tejlgaard and Benny Jepsen, 2013.

The Dome Cookbook, Steve Baer, 1968.

Louis Kahn

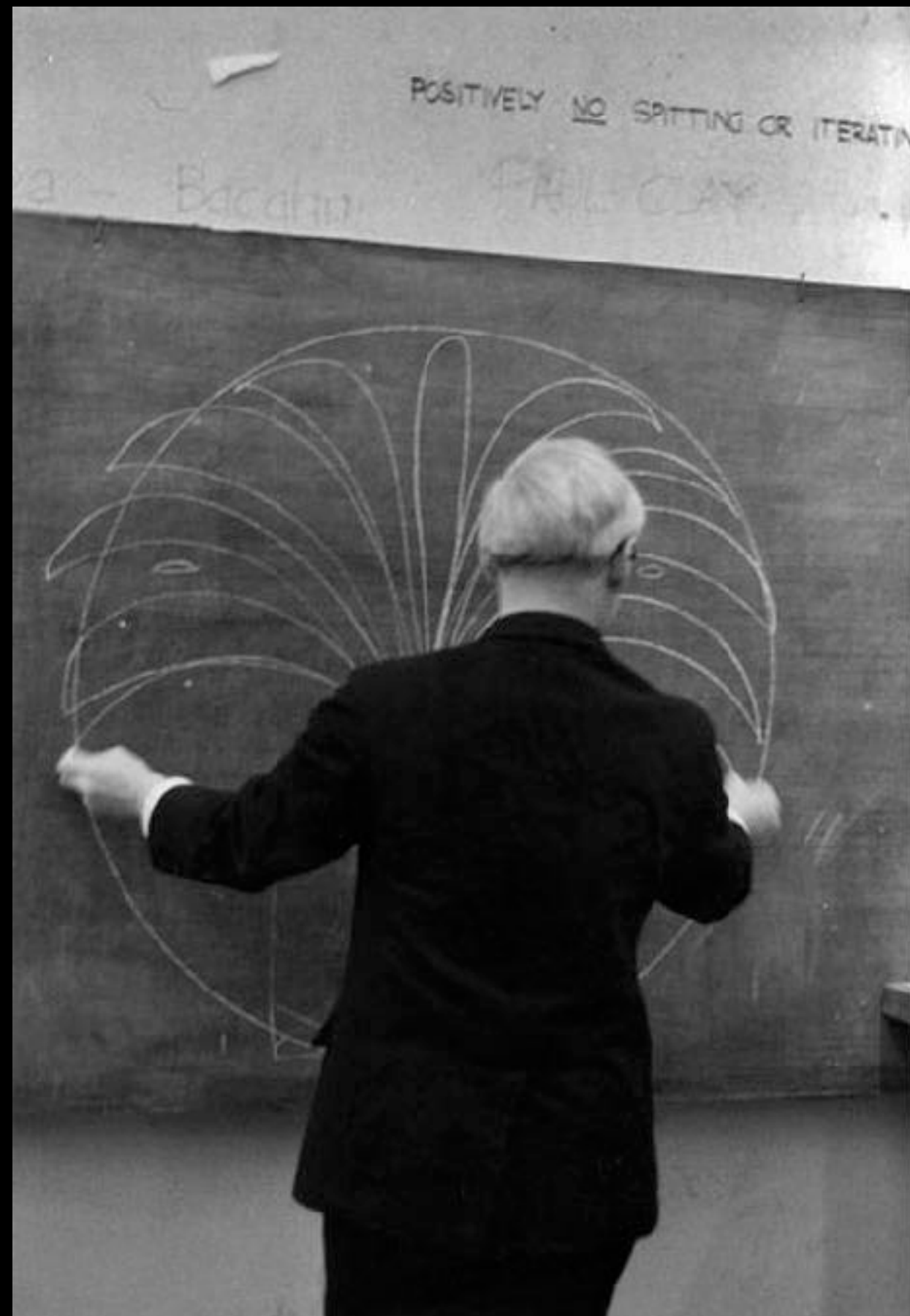

1901-1974

Louis Kahn

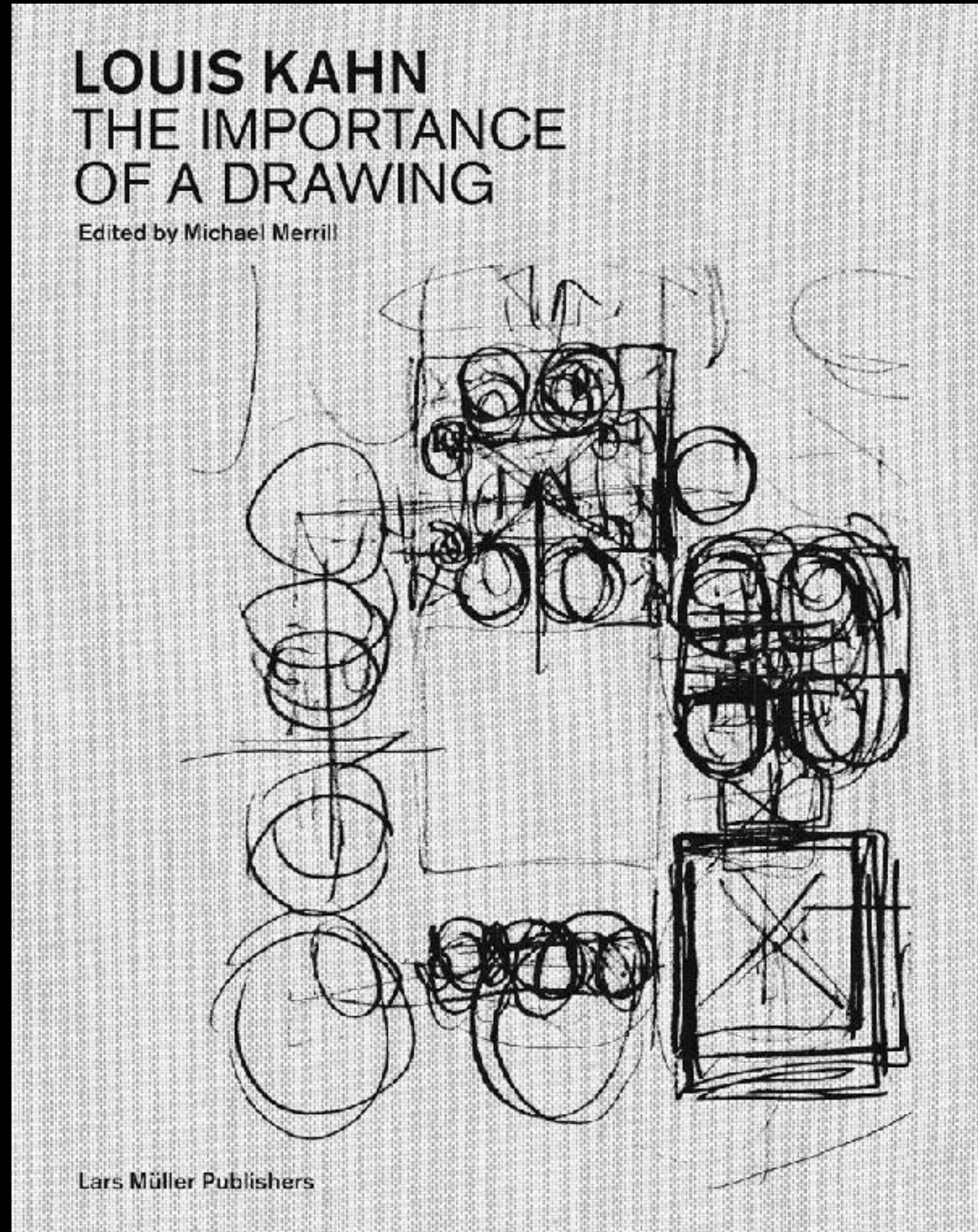

Louis Kahn

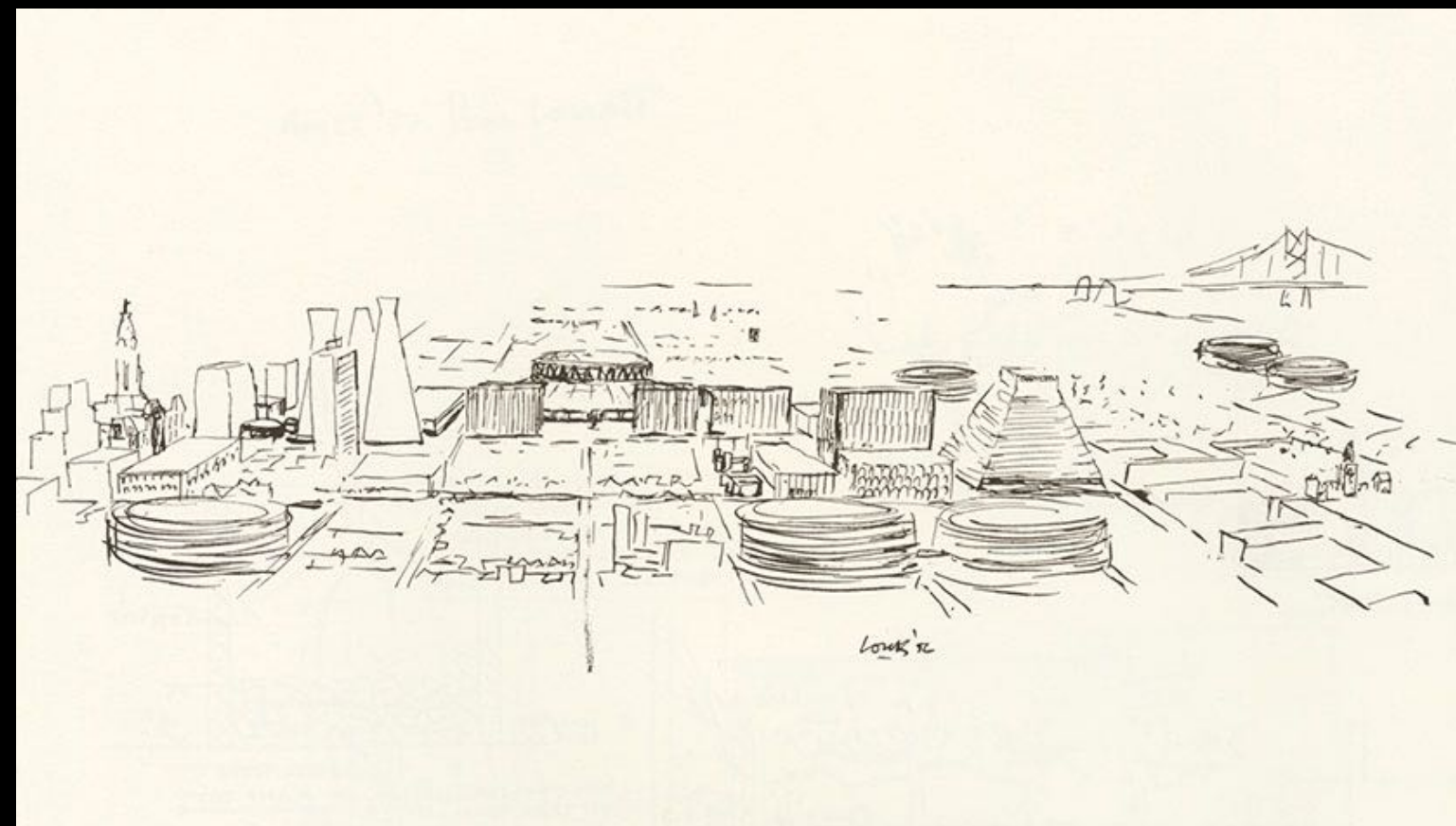
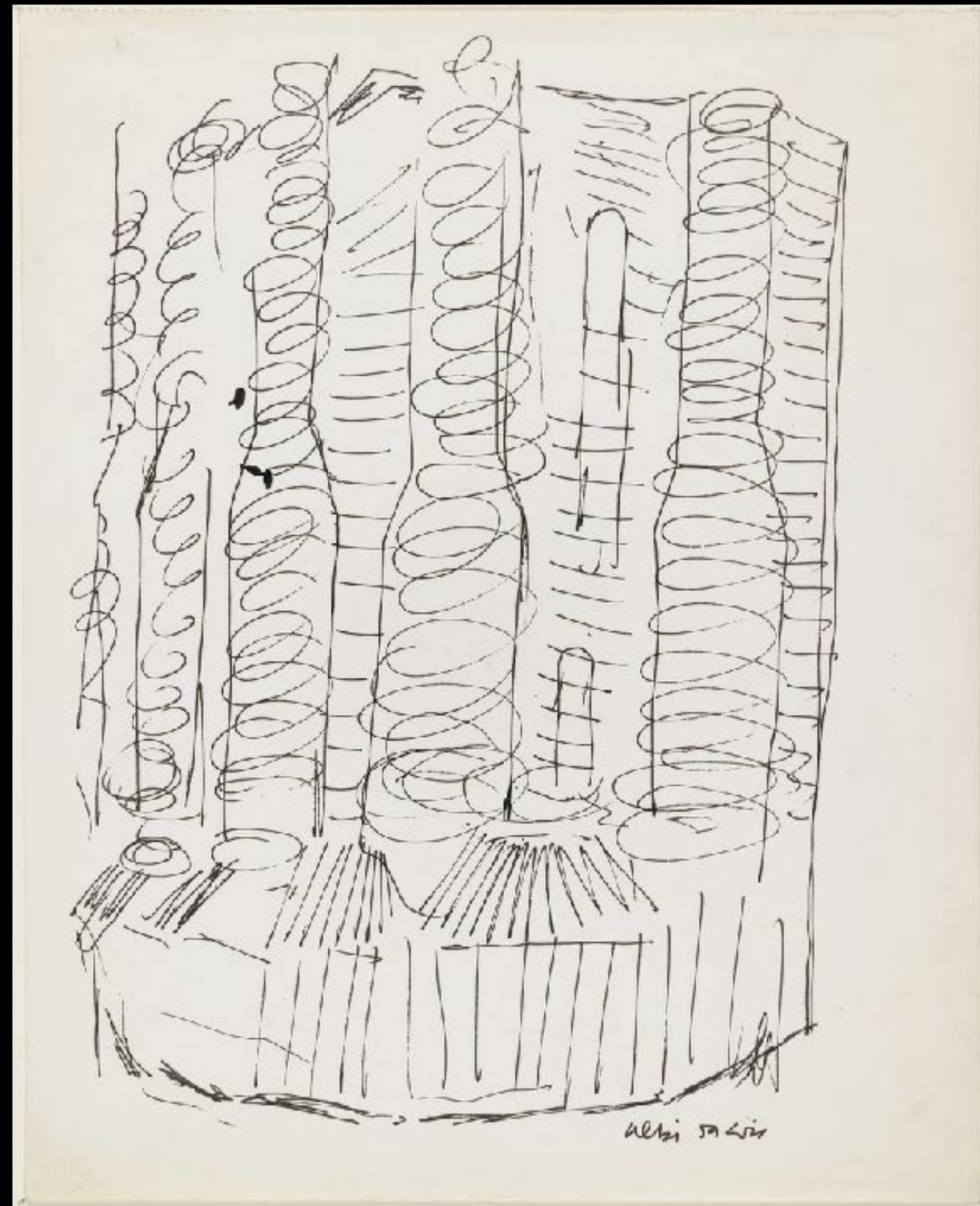

Louis Kahn



Buckminster Fuller as an inspiration for Loop Design



Sketch furniture by Front

Biennal 2021 - Maison Fibre



Biennal 2021 - Maison Fibre



Maison Fibre

Towards a Novel Material Culture

17th International Architecture Exhibition
La Biennale di Venezia 2021

Exercise 10

SHADOWS

30 min

Sketching Form

Shading

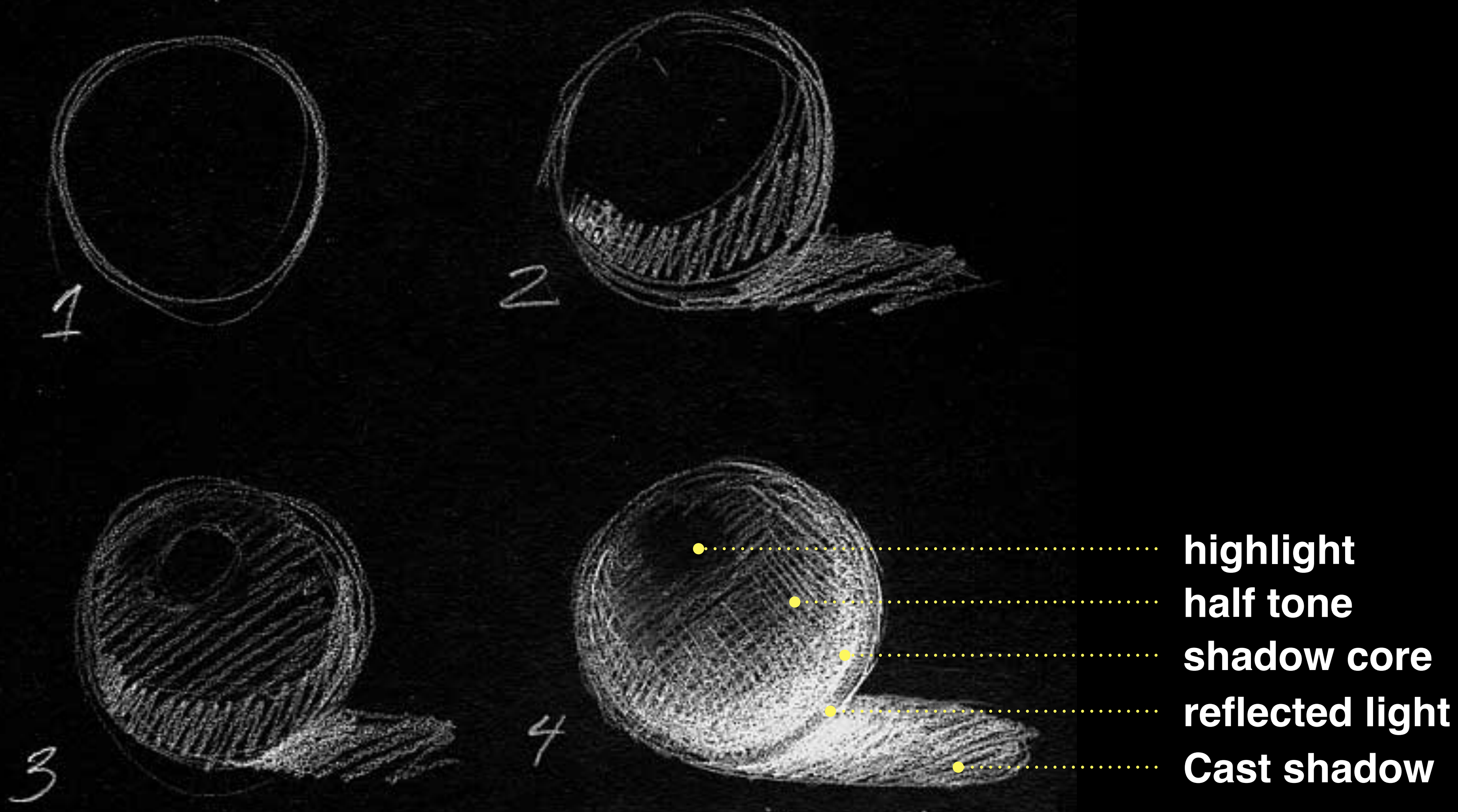

Exercise 11

ORGANIZE A FULL PAPER WITH ALL SKETCHING TECHNIQUES

1 hour

Thank you!

Contact

Rasa Weber | rasa.weber@zhdk.ch

Z

hdk

Zürcher Hochschule der Künste
Bachelor of Arts in Design